



westonandsampson.com

55 Walkers Brook Drive, Suite 100  
Reading, MA 01867  
tel: 978.532.1900

## Request for Determination of Applicability



December 2022

### **GROVE STREET LOT 5 PARKING LOT READING, MASSACHUSETTS**

PREPARED FOR:  
TOWN OF READING ENGINEERING DEPT.  
16 LOWELL STREET  
READING, MA 01867

SUBMITTED TO:  
READING CONSERVATION COMMISSION  
16 LOWELL STREET  
READING, MA 01867



December 20, 2022

Reading Conservation Commission  
16 Lowell Street  
Reading, Massachusetts 01867

**Re: Request for Determination of Applicability  
Grove Street – Lot 5 Parking Lot  
Reading, Massachusetts**

Dear Members of the Commission:

On behalf of the Town of Reading Engineering Department, Weston & Sampson Engineers, Inc. is hereby enclosing two (2) hard copies of the Request for Determination of Applicability (RDA) package to fulfill the requirements of the Massachusetts Wetlands Protection Act and the Reading Conservation Commission submittal requirements. One electronic copy (PDF) was emailed to Chuck Tirone, Reading Conservation Commission agent. One hard copy was mailed to Martha Moore, Chair of the Reading Conservation Commission, at 102 Sandborn Lane, Reading, MA.

No filing fees are included because the project is designated as a town project and is exempt under the local bylaw under Section 7.1.14. This submittal is a formal RDA for the Grove Street Lot 5 Parking Lot Project within the Town of Reading. As part of the filing, we have attached the following:

WPA Form 1 (RDA Form)

- Appendix A: Project Description
- Appendix B: Wetland Delineation Report
- Appendix C: Project Maps
- Appendix D: Project Plans

If you have any questions regarding this submittal, please contact me at (978) 548-6301 or via email at kearns.megan@wseinc.com.

Very truly yours,

WESTON & SAMPSON, INC.



Megan Kearns, PWS  
Project Environmental Scientist



# WPA Form 1- Request for Determination of Applicability

Massachusetts Wetlands Protection Act M.G.L. c. 131, §40

## A. General Information

**Important:**  
When filling out forms on the computer, use only the tab key to move your cursor - do not use the return key.



1. Applicant:

Fidel Maltez, Reading Town Manager		fmaltez@ci.reading.ma.us	
Name		E-Mail Address	
16 Lowell Street			
Mailing Address			
Reading	MA	01867	
City/Town	State	Zip Code	
781-942-9043	Fax Number (if applicable)		
Phone Number			

2. Representative (if any):

Weston & Sampson Engineers, Inc.			
Firm			
Megan Kearns		kearns.megan@wseinc.com	
Contact Name		E-Mail Address	
55 Walkers Brook Drive, Suite 100			
Mailing Address			
Reading	MA	01867	
City/Town	State	Zip Code	
978-548-6301	Fax Number (if applicable)		
Phone Number			

## B. Determinations

1. I request the Reading Conservation Commission make the following determination(s). Check any that apply:

- a. whether the **area** depicted on plan(s) and/or map(s) referenced below is an area subject to jurisdiction of the Wetlands Protection Act.
- b. whether the **boundaries** of resource area(s) depicted on plan(s) and/or map(s) referenced below are accurately delineated.
- c. whether the **work** depicted on plan(s) referenced below is subject to the Wetlands Protection Act.
- d. whether the area and/or work depicted on plan(s) referenced below is subject to the jurisdiction of any **municipal wetlands ordinance** or **bylaw** of:

Reading  
Name of Municipality

- e. whether the following **scope of alternatives** is adequate for work in the Riverfront Area as depicted on referenced plan(s).





## WPA Form 1- Request for Determination of Applicability

Massachusetts Wetlands Protection Act M.G.L. c. 131, §40

### C. Project Description (cont.)

b. Identify provisions of the Wetlands Protection Act or regulations which may exempt the applicant from having to file a Notice of Intent for all or part of the described work (use additional paper, if necessary).

Work is within buffer zone only and there will be no impacts to wetland resource areas protected under the Massachusetts Wetlands Protection Act.

---

---

3. a. If this application is a Request for Determination of Scope of Alternatives for work in the Riverfront Area, indicate the one classification below that best describes the project.

- Single family house on a lot recorded on or before 8/1/96
- Single family house on a lot recorded after 8/1/96
- Expansion of an existing structure on a lot recorded after 8/1/96
- Project, other than a single family house or public project, where the applicant owned the lot before 8/7/96
- New agriculture or aquaculture project
- Public project where funds were appropriated prior to 8/7/96
- Project on a lot shown on an approved, definitive subdivision plan where there is a recorded deed restriction limiting total alteration of the Riverfront Area for the entire subdivision
- Residential subdivision; institutional, industrial, or commercial project
- Municipal project
- District, county, state, or federal government project
- Project required to evaluate off-site alternatives in more than one municipality in an Environmental Impact Report under MEPA or in an alternatives analysis pursuant to an application for a 404 permit from the U.S. Army Corps of Engineers or 401 Water Quality Certification from the Department of Environmental Protection.

b. Provide evidence (e.g., record of date subdivision lot was recorded) supporting the classification above (use additional paper and/or attach appropriate documents, if necessary.)

---

---

---



# WPA Form 1- Request for Determination of Applicability

Massachusetts Wetlands Protection Act M.G.L. c. 131, §40

## D. Signatures and Submittal Requirements

I hereby certify under the penalties of perjury that the foregoing Request for Determination of Applicability and accompanying plans, documents, and supporting data are true and complete to the best of my knowledge.

I further certify that the property owner, if different from the applicant, and the appropriate DEP Regional Office were sent a complete copy of this Request (including all appropriate documentation) simultaneously with the submittal of this Request to the Conservation Commission.

Failure by the applicant to send copies in a timely manner may result in dismissal of the Request for Determination of Applicability.

Name and address of the property owner:

Town of Reading  
Name

---

16 Lowell Street  
Mailing Address

---

Reading  
City/Town

---

MA  
State

---

01867  
Zip Code

---

Signatures:

I also understand that notification of this Request will be placed in a local newspaper at my expense in accordance with Section 10.05(3)(b)(1) of the Wetlands Protection Act regulations.

Signature of Applicant

Signature of Representative (if any)

Date

12/13/2022

Date

## APPENDIX A

## PROJECT DESCRIPTION

### ***Background:***

The Town of Reading is proposing to construct a new parking lot located off of Grove Street. The proposed parking lot would provide off-street parking for people using the existing trail system in the Reading Town Forest. Currently, cars park on the side of the street creating an unsafe situation on the road.

### ***Site Description:***

The project site is located on the northern side of Grove Street in Reading, Massachusetts. The Reading Town Forest borders the site to the north, the Meadow Brook Golf Club to the southeast, and residential houses to the southwest. The Ipswich River runs along the northern portion of the Town Forest, with large wetland systems located along the river.

### ***Work Description:***

Work will include the construction of a gravel parking lot with seventeen (17) parking spaces, including two (2) handicap-accessible spaces. Two portable toilets are proposed just north of the handicap-accessible parking spaces. Twenty-five (25) trees are proposed to be cut down to accommodate the parking lot. Twenty-four (24) trees are not located in wetland resource areas and are outside of the 100-foot Buffer Zone to Bordering Vegetated Wetlands (BVW); only one tree is located along the edge of the 100-foot Buffer Zone. The site will be re-graded to accommodate the parking lot. A walking path is proposed to connect the existing walking trails with the parking lot. The path will match the existing grade and will consist of 4 inches of dense graded  $\frac{3}{4}$ " crushed stone on top of a geotextile filter fabric, on top of 12" of a gravel subbase with a topping layer of stone dust for ADA accessibility.

During construction, compost filter tubes will be installed in between the proposed work and the nearby BVW. In addition, a stabilized construction entrance will be installed to prevent sediment and other material from being tracked out onto the roadway during construction.

### ***Environmental Considerations:***

The proposed parking lot has been designed to have no impact to resource areas protected under the Massachusetts Wetlands Protection Act and the local Reading Wetland Bylaw. A total of 400 square feet of work is proposed within the 100-foot Buffer Zone. The gravel parking lot will be located outside of the 100-foot Buffer Zone, with portions of the proposed 4-foot-wide walking path to connect the parking lot to the existing trail system located in the 100-foot Buffer Zone. All disturbed areas outside of the parking lot but within the limit of work will be restored with loam and seed after construction.

The entire site (22,507 square feet/0.52 acres) is located within NHESP Priority Habitats of Rare Species and NHESP Estimated Habitats of Rare Wildlife. The applicant has consulted with NHESP on the design of the project, and a separate filing is being submitted concurrently with NHESP.

## APPENDIX B

# Wetland Delineation Report



August 2022

Reading, Massachusetts  
Project # ENG22-0527

Grove Street Parcel

Wetland Delineation Conducted By:  
Megan Kearns, PWS on 8/3/2022

Delineation Report Reviewed By:  
Mel Higgins, PWS



## TABLE OF CONTENTS

	Page
1.0 SITE DESCRIPTION .....	1-1
2.0 DELINEATION OF WETLAND RESOURCES.....	2-1
2.1 Site Observations.....	2-1
2.2 Wetland Delineation Methodology.....	2-1
2.3 Bordering Vegetated Wetlands (BVW).....	2-2
2.5 Other Protected Areas.....	2-3
3.0 SUMMARY .....	3-1
4.0 REFERENCES .....	4-1

## FIGURES

Figure 1 .....	Wetlands Field Map
Figure 2 .....	USGS Topographic Map
Figure 3 .....	FEMA FIRM Map
Figure 4 .....	Environmental Resources Map

## APPENDICES

Appendix A .....	ACOE Wetland Determination Data Forms
Appendix B .....	Site Photographs

## 1.0 SITE DESCRIPTION

On August 3, 2022, the presence of wetland resources was investigated near the Grove Street Parcel in Reading, Massachusetts. This investigation area is located adjacent to undeveloped forested areas with walking trails, residential houses, and the Meadow Brook Golf Club. Please see Figure 1 (Wetlands Field Map) and Figure 2 (USGS Topographic Map) of this report for the investigation area.

A bordering vegetated wetland (BVW) was identified and flagged in the field using pink flagging by a Weston & Sampson employee who is trained in the wetland delineation process using the Massachusetts Department of Environmental Protection (MassDEP) and the US Army Corps of Engineers methodology. Further descriptions of the wetland resource area are presented in the following sections.

## 2.0 DELINEATION OF WETLAND RESOURCES

### 2.1 Site Observations

The Weston & Sampson wetland scientist, trained in the ACOE Wetland Delineation Manual and Massachusetts Department of Environmental Protection (MassDEP) Delineating Bordering Vegetated Wetlands Under the Massachusetts Wetland Protection Act guidance document, observed the following protected wetland resources at the site:

- Bordering Vegetated Wetlands (BVW)

Field data were recorded on US Army Corps of Engineers (ACOE) Wetland Determination Data Forms. See Appendix A for completed data forms and Appendix B for site photographs.

### 2.2 Wetland Delineation Methodology

A wetland delineation assessment was conducted in accordance with the Massachusetts Wetland Protection Act Regulations (310 CMR 10.55(2)(c)), Massachusetts Department of Environmental Protection (MassDEP) Delineating Bordering Vegetated Wetlands Under the Massachusetts Protection Act (March 1995), and ACOE Wetland Manual (Technical Report Y-87-1).

The BVW delineation methodology included the characterization of vegetation, soil and hydrologic conditions in both wetland and upland areas to identify the transitional area, which was used as the wetland limit. Pink flags with distinct flag numbers were left in the field to show wetland resource area limits.

Vegetation, hydrology and soils were assessed in both wetland and upland areas to accurately place the wetland limits at each site. The percentage of vegetative species was estimated by creating sample plots. Sample plot radius for trees, saplings, shrubs, groundcover and woody vine strata was 30', 15', 15', 5' and 30', respectively. After creating the sample plot areas, the percent basal area coverage of each species within the monitoring plot was recorded. Using these field observations, the percent dominance of each species within its stratum was calculated. The 50/20 Rule was then used to determine dominance. Dominant species were considered the most abundant plant species (when ranked in descending order of abundance and cumulatively totaled) that immediately exceeds 50% of the total dominance measure (basal area) for the

stratum, plus any additional species comprising 20% or more of the total dominance measure for the stratum. Once the dominant species were determined, they were treated equally to determine the presence of hydrophytic vegetation. If the number of dominant species with a Wetland Indicator Status of FAC, FACW or OBL is greater than, or equal to, the number of remaining dominant species, the area was considered a jurisdictional wetland resource area based on vegetation.

A soil sample from each wetland sample plot were also taken. Each soil sample goes to a depth of at least 12-24 inches. The soil was characterized to determine if the soil sample was considered a hydric (wetland) soil. Soil samples, including mottles, were characterized based on color using Munsell Soil-Color charts as a color reference.

The general area was then assessed for hydrologic conditions, including, but not limited to, site inundation, depth to free water, depth of soil saturation, water marks, drift lines, sediment deposits, water-stained leaves.

### 2.3 Bordering Vegetated Wetlands (BVW)

A single BVW series was delineated at the site. This BVW is located adjacent to wetland resource areas associated with the Ipswich River to the north. The limit of the BVW resource areas were determined by locating the transitional area between wetland and upland vegetation, soils and hydrologic conditions. Wetland flags left in the field included:

- BVW-A1 through BVW-A28 (BVW "A" Series)

Dominant vegetation within the wetland resource area included highbush blueberry (*Vaccinium corymbosum*), sweet pepperbush (*Clethra alnifolia*), red maple (*Acer rubrum*), and European buckthorn (*Rhamnus cathartica*), species that generally thrive in wet conditions. Soils within the BVW's were composed of sandy loam with redoximorphic features. Other indicators of wetland hydrology included high water table, saturation, geomorphic position, buttressed roots, and water-stained leaves.

Dominant upland vegetation in the area included eastern white pine (*Pinus strobus*), red oak (*Quercus rubra*), and red maple (*Acer rubrum*). Soils within the upland were composed of fine sandy loam with no evidence of mottling or hydrology within the top 12 inches.

BVWs are subject to a 100-foot buffer under the Massachusetts Wetland Protection Act per 310 CMR 10.02(2)(b), and the local Reading wetlands Protection (Section 7.1).

## 2.5 Other Protected Areas

Weston & Sampson created environmental resources maps (see Figure 4) of the site to determine the presence of other protected areas. The data source of these map layers was the Massachusetts Geographic Information System (MassGIS). These areas included:

- NHESP Priority Habitats of Rare Species
- NHESP Estimated Habitats of Rare Wildlife
- NHESP Certified and Potential Vernal Pools
- Areas of Critical Environmental Concern (ACEC)
- Outstanding Resource Waters (ORW)
- Coldwater Fisheries

Wetland resources identified in the field were also added to these maps. Based on the MassGIS information, the entire site is located within NHESP Priority Habitats of Rare Species and NHESP Estimated Habitat of Rare Wildlife. A Certified Vernal Pool is located in the mapped BVW wetland (Series A).

FEMA Flood Insurance Rate Maps (FIRM) were created online from the FEMA website to determine if there is a 100-year flood zone at the site. See Figure 3 for FIRM map. Based on FEMA flood maps, community panel number 25017C0292E (dated 6/4/2010) the investigation area is not located within the 100-year flood zone. The 100-year flood zone is mapped adjacent to the study area, overlapping with the mapped BVW wetland (Series A).

The Massachusetts Wetland Protection Act does not place a buffer zone on the 100-year flood zone (Bordering Land Subject to Flooding).

## 3.0 SUMMARY

On August 2, 2022, the presence of wetland resources was investigated near the Grove Street parcel in Reading, MA. A single bordering vegetated wetland was identified and flagged at the site.

Additional environmental mapping was conducted using MassGIS data layers and FEMA FIRM mapping. This additional mapping indicates that the entire site is located within NHESP Priority Habitats of Rare Species and NHESP Estimated Habitat of Rare Wildlife. The BVW adjacent to the investigation area is also mapped as a Certified Vernal Pool.

This Wetlands Delineation Report has been reviewed and approved by a Professional Wetland Scientist PWS.

#### 4.0 REFERENCES

Jackson, Scott. 1995. "Delineating Bordering Vegetated Wetlands Under the Massachusetts Wetlands Protection Act." Massachusetts Department of Environmental Protection.

Massachusetts Division of Fisheries and Wildlife, Natural Heritage and Endangered Species Program. Massachusetts Natural Heritage Atlas, 13th Edition with 2017 web updates. Accessed on 8/5/2022.

Massachusetts Geographic Information System. January 2009. Outstanding Resource Waters. Massachusetts Department of Environmental Protection. Accessed on 8/5/2022.

Massachusetts Geographic Information System. December 2003. Areas of Critical Environmental Concern. Massachusetts Department of Environmental Protection. Accessed on 8/5/2022.

Newcomb, Lawrence. 1977. Newcomb's Wildflower Guide. Little, Brown and Company.

Web Soil Survey of Middlesex County, Massachusetts. United States Department of Agriculture, Soil Conservation Service, in cooperation with Massachusetts Agricultural Experiment Station

United States Department of Agriculture, Natural Resources Conservation Service. 2018. *Field Indicators of Hydric Soils in the United States, Version 8.2*. L. M. Vasilas, G. W. Hurt, and J.F. Berkowitz (eds.). USDA, NRCS, in cooperation with the National Technical Committee for Hydric Soils.

USACOE, January 1987, Corps of Engineers Wetlands Delineation Manual, Wetlands Research Program Technical Report Y-87-1.

FEMA Flood Map Service Center, online at [msc.fema.gov/portal](http://msc.fema.gov/portal) Assessed on 8/5/2022.

Tiner, Jr., Ralph W., 2005, Field Guide to Nontidal Wetland Identification

Tiner, Jr., Ralph W, 2009, Field Guide to Tidal Wetland Plants of the Northeastern United States and Neighboring Canada.

Wojtec, Michael, Bard – A field Guide to Trees of the Northeast.

New England Hydric Soils Technical Committee, 2019, Version 4, *Field Indicator of Identifying Hydric Soils in New England*. New England Interstate Water Pollution Control Commission, Lowell, MA.



### Legend

- Wetland Flags
- Wetland Lines
- Work Area
- Marsh/Bog
- Wooded marsh
- Cranberry Bog
- Salt Marsh
- Open Water
- Reservoir (with PWSID)
- Tidal Flats
- Beach/Dune
- MA Towns
- Parcel
- Parcel

**FIGURE 1**

Grove Street Parcel  
Reading, MA

Delineation Map

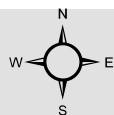

Data Source: Office of Geographic and Environmental Information (MassGIS),  
Commonwealth of Massachusetts Executive Office of Environmental Affairs





- Legend**
-  Work Area
  -  MA Towns

**FIGURE 2**

Grove Street Parcel  
Reading, MA

USGS Map

# National Flood Hazard Layer FIRMMette



71°08'5"W 42°33'1"N

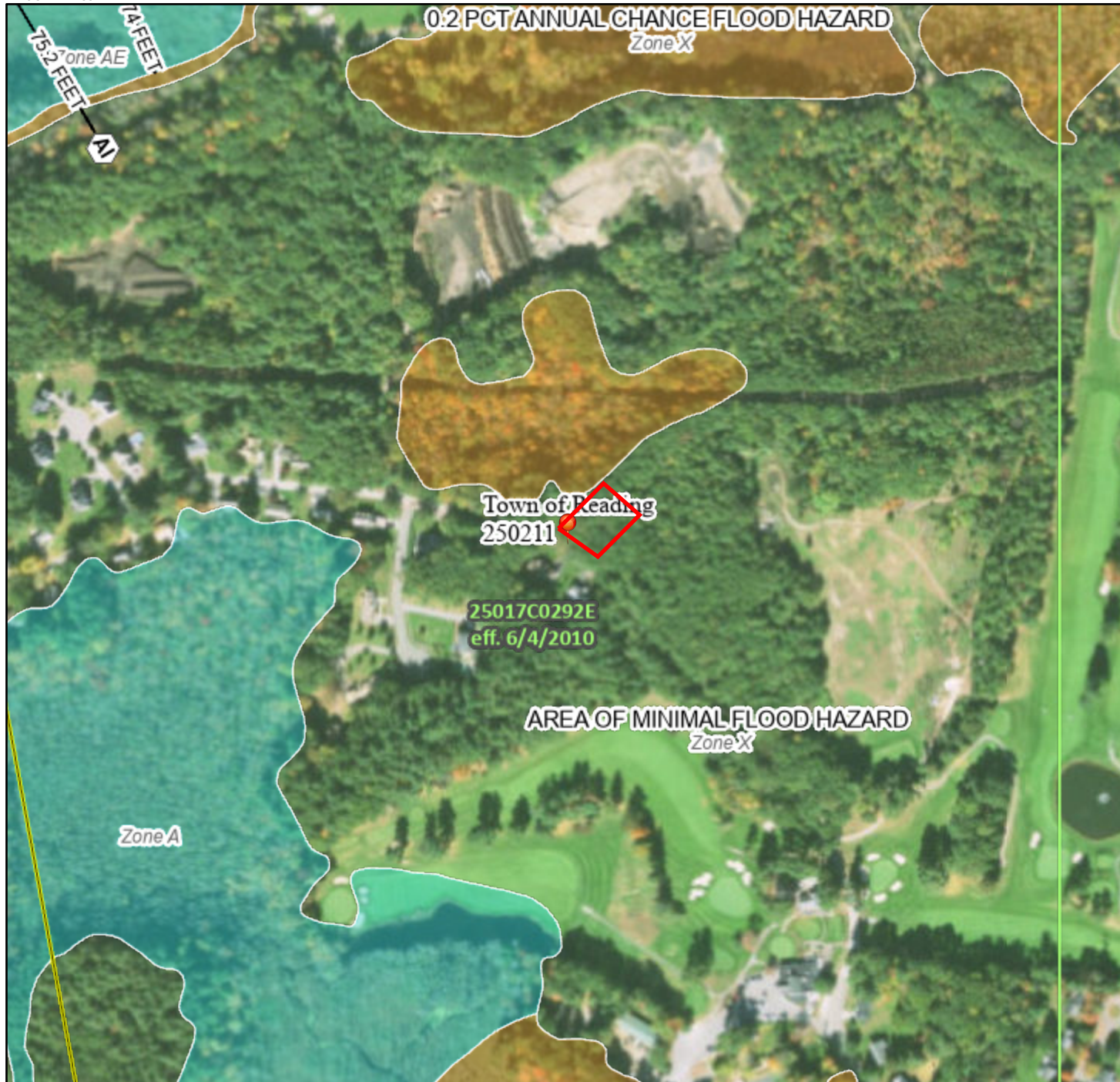

## Legend

SEE FIS REPORT FOR DETAILED LEGEND AND INDEX MAP FOR FIRM PANEL LAYOUT

SPECIAL FLOOD HAZARD AREAS	Without Base Flood Elevation (BFE) Zone A, V, A99	With BFE or Depth Zone AE, AO, AH, VE, AR
		Regulatory Floodway

		0.2% Annual Chance Flood Hazard, Areas of 1% annual chance flood with average depth less than one foot or with drainage areas of less than one square mile Zone X
		Future Conditions 1% Annual Chance Flood Hazard Zone X
		Area with Reduced Flood Risk due to Levee. See Notes. Zone X
		Area with Flood Risk due to Levee Zone D

### OTHER AREAS OF FLOOD HAZARD

		NO SCREEN Area of Minimal Flood Hazard Zone X
		Effective LOMRs
		Area of Undetermined Flood Hazard Zone D

### OTHER AREAS

GENERAL STRUCTURES		Channel, Culvert, or Storm Sewer
		Levee, Dike, or Floodwall

		20.2 Cross Sections with 1% Annual Chance Water Surface Elevation
		17.5 Cross Sections with 1% Annual Chance Water Surface Elevation
		Coastal Transect
		Base Flood Elevation Line (BFE)
		Limit of Study
		Jurisdiction Boundary
		Coastal Transect Baseline
		Profile Baseline
		Hydrographic Feature

### OTHER FEATURES

		Digital Data Available
		No Digital Data Available
		Unmapped

**MAP PANELS**

The pin displayed on the map is an approximate point selected by the user and does not represent an authoritative property location.

This map complies with FEMA's standards for the use of digital flood maps if it is not void as described below. The basemap shown complies with FEMA's basemap accuracy standards

The flood hazard information is derived directly from the authoritative NFHL web services provided by FEMA. This map was exported on **8/4/2022 at 1:00 PM** and does not reflect changes or amendments subsequent to this date and time. The NFHL and effective information may change or become superseded by new data over time.

This map image is void if the one or more of the following map elements do not appear: basemap imagery, flood zone labels, legend, scale bar, map creation date, community identifiers, FIRM panel number, and FIRM effective date. Map images for unmapped and unmodernized areas cannot be used for regulatory purposes.



**Legend**

- Wetland Flags
- Wetland Lines
- Work Area
- Hydrologic Connection
- Perennial Stream
- Intermittent Stream
- Marsh/Bog
- Wooded marsh
- Cranberry Bog
- Salt Marsh
- Open Water
- Reservoir (with PWSID)
- Tidal Flats
- Beach/Dune
- MA Towns
- Parcel
- Parcel
- ACECs**
- ACECs
- NHESP Habitats**
- NHESP Estimated Habitats of Rare Wildlife
- NHESP Priority Habitats of Rare Species
- NHESP Certified Vernal Pools
- NHESP Potential Vernal Pools
- Cold Water Fisheries
- Outstanding Resource Waters**
- Public Water Supply Contributor
- ORW for ACEC
- ORW for both Water Supply and Other

**FIGURE 4**

Grove Street Parcel  
Reading, MA

Environmental  
Constraints Map

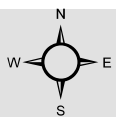

0 75 150 300  
Feet

Data Source: Office of Geographic and Environmental Information (MassGIS),  
Commonwealth of Massachusetts Executive Office of Environmental Affairs



## APPENDIX A

### ACOE Wetland Determination Data Forms

## WETLAND DETERMINATION DATA FORM – Northcentral and Northeast Region

Project/Site: Grove Street Parcel City/County: Reading Sampling Date: 8/3/22  
 Applicant/Owner: Town of Reading, Engineering Department State: MA Sampling Point: WET-BVWAZ3  
 Investigator(s): Megan Kearns, PWS Section, Township, Range: \_\_\_\_\_  
 Landform (hillside, terrace, etc.): Hillside Local relief (concave, convex, none): None Slope (%): 1%  
 Subregion (LRR or MLRA): LRR R, MLRA 144A Lat: 42.546961 Long: -71.129381 Datum: WGS84  
 Soil Map Unit Name: Freetown muck, 0 to 1 percent slopes NWI classification: PFO

Are climatic / hydrologic conditions on the site typical for this time of year? Yes \_\_\_\_\_ No X (If no, explain in Remarks.)  
 Are Vegetation \_\_\_\_\_, Soil \_\_\_\_\_, or Hydrology \_\_\_\_\_ significantly disturbed? Are "Normal Circumstances" present? Yes X No \_\_\_\_\_  
 Are Vegetation \_\_\_\_\_, Soil \_\_\_\_\_, or Hydrology \_\_\_\_\_ naturally problematic? (If needed, explain any answers in Remarks.)

### SUMMARY OF FINDINGS – Attach site map showing sampling point locations, transects, important features, etc.

Hydrophytic Vegetation Present? Yes <u>X</u> No _____ Hydric Soil Present? Yes <u>X</u> No _____ Wetland Hydrology Present? Yes <u>X</u> No _____	<b>Is the Sampled Area within a Wetland?</b> Yes <u>X</u> No _____ If yes, optional Wetland Site ID: _____
Remarks: (Explain alternative procedures here or in a separate report.) Drought recorded.	

### HYDROLOGY

<b>Wetland Hydrology Indicators:</b> <u>Primary Indicators (minimum of one is required; check all that apply)</u> _____ Surface Water (A1) <u>X</u> Water-Stained Leaves (B9) <u>X</u> High Water Table (A2)                          _____ Aquatic Fauna (B13) <u>X</u> Saturation (A3)                                      _____ Marl Deposits (B15) _____ Water Marks (B1)                          _____ Hydrogen Sulfide Odor (C1) _____ Sediment Deposits (B2) <u>X</u> Oxidized Rhizospheres on Living Roots (C3) _____ Drift Deposits (B3)                              _____ Presence of Reduced Iron (C4) _____ Algal Mat or Crust (B4)                          _____ Recent Iron Reduction in Tilled Soils (C6) _____ Iron Deposits (B5)                              _____ Thin Muck Surface (C7) _____ Inundation Visible on Aerial Imagery (B7)      _____ Other (Explain in Remarks) _____ Sparsely Vegetated Concave Surface (B8)	<u>Secondary Indicators (minimum of two required)</u> _____ Surface Soil Cracks (B6) <u>X</u> Drainage Patterns (B10) _____ Moss Trim Lines (B16) _____ Dry-Season Water Table (C2) _____ Crayfish Burrows (C8) _____ Saturation Visible on Aerial Imagery (C9) _____ Stunted or Stressed Plants (D1) <u>X</u> Geomorphic Position (D2) _____ Shallow Aquitard (D3) _____ Microtopographic Relief (D4) <u>X</u> FAC-Neutral Test (D5)
--	--

<b>Field Observations:</b> Surface Water Present? Yes _____ No <u>X</u> Depth (inches): _____ Water Table Present? Yes <u>X</u> No _____ Depth (inches): <u>6"</u> Saturation Present? Yes <u>X</u> No _____ Depth (inches): <u>0"</u> (includes capillary fringe)	<b>Wetland Hydrology Present?</b> Yes <u>X</u> No _____
--	---

Describe Recorded Data (stream gauge, monitoring well, aerial photos, previous inspections), if available:

Remarks:

**VEGETATION** – Use scientific names of plants.

Sampling Point: WET-BVWA23

	Absolute % Cover	Dominant Species?	Indicator Status																	
<b>Tree Stratum</b> (Plot size: <u>30</u> )																				
1. <u><i>Acer rubrum</i></u>	<u>60</u>	Yes	FAC	<b>Dominance Test worksheet:</b>  Number of Dominant Species That Are OBL, FACW, or FAC: <u>3</u> (A)  Total Number of Dominant Species Across All Strata: <u>3</u> (B)  Percent of Dominant Species That Are OBL, FACW, or FAC: <u>100.0%</u> (A/B)																
2. _____	_____	_____	_____																	
3. _____	_____	_____	_____																	
4. _____	_____	_____	_____																	
5. _____	_____	_____	_____																	
6. _____	_____	_____	_____																	
7. _____	_____	_____	_____																	
	<u>60</u> =Total Cover			<b>Prevalence Index worksheet:</b>  <table style="width:100%; border:none;"> <tr> <td style="width:50%; text-align:right;">Total % Cover of:</td> <td style="width:50%; text-align:left;">Multiply by:</td> </tr> <tr> <td>OBL species <u>0</u></td> <td>x 1 = <u>0</u></td> </tr> <tr> <td>FACW species <u>30</u></td> <td>x 2 = <u>60</u></td> </tr> <tr> <td>FAC species <u>70</u></td> <td>x 3 = <u>210</u></td> </tr> <tr> <td>FACU species <u>0</u></td> <td>x 4 = <u>0</u></td> </tr> <tr> <td>UPL species <u>0</u></td> <td>x 5 = <u>0</u></td> </tr> <tr> <td>Column Totals: <u>100</u> (A)</td> <td><u>270</u> (B)</td> </tr> <tr> <td colspan="2" style="text-align:center;">Prevalence Index = B/A = <u>2.70</u></td> </tr> </table>	Total % Cover of:	Multiply by:	OBL species <u>0</u>	x 1 = <u>0</u>	FACW species <u>30</u>	x 2 = <u>60</u>	FAC species <u>70</u>	x 3 = <u>210</u>	FACU species <u>0</u>	x 4 = <u>0</u>	UPL species <u>0</u>	x 5 = <u>0</u>	Column Totals: <u>100</u> (A)	<u>270</u> (B)	Prevalence Index = B/A = <u>2.70</u>	
Total % Cover of:	Multiply by:																			
OBL species <u>0</u>	x 1 = <u>0</u>																			
FACW species <u>30</u>	x 2 = <u>60</u>																			
FAC species <u>70</u>	x 3 = <u>210</u>																			
FACU species <u>0</u>	x 4 = <u>0</u>																			
UPL species <u>0</u>	x 5 = <u>0</u>																			
Column Totals: <u>100</u> (A)	<u>270</u> (B)																			
Prevalence Index = B/A = <u>2.70</u>																				
<b>Sapling/Shrub Stratum</b> (Plot size: <u>15</u> )																				
1. <u><i>Vaccinium corymbosum</i></u>	<u>30</u>	Yes	FACW																	
2. <u><i>Clethra alnifolia</i></u>	<u>10</u>	Yes	FAC																	
3. _____	_____	_____	_____																	
4. _____	_____	_____	_____																	
5. _____	_____	_____	_____																	
6. _____	_____	_____	_____																	
7. _____	_____	_____	_____																	
	<u>40</u> =Total Cover																			
<b>Herb Stratum</b> (Plot size: <u>5</u> )																				
1. _____	_____	_____	_____																	
2. _____	_____	_____	_____																	
3. _____	_____	_____	_____																	
4. _____	_____	_____	_____																	
5. _____	_____	_____	_____																	
6. _____	_____	_____	_____																	
7. _____	_____	_____	_____																	
8. _____	_____	_____	_____																	
9. _____	_____	_____	_____																	
10. _____	_____	_____	_____																	
11. _____	_____	_____	_____																	
12. _____	_____	_____	_____																	
	_____ =Total Cover																			
<b>Woody Vine Stratum</b> (Plot size: <u>15</u> )																				
1. _____	_____	_____	_____																	
2. _____	_____	_____	_____																	
3. _____	_____	_____	_____																	
4. _____	_____	_____	_____																	
	_____ =Total Cover																			
<b>Hydrophytic Vegetation Indicators:</b> <input type="checkbox"/> 1 - Rapid Test for Hydrophytic Vegetation <input checked="" type="checkbox"/> 2 - Dominance Test is >50% <input checked="" type="checkbox"/> 3 - Prevalence Index is ≤3.0 <sup>1</sup> <input type="checkbox"/> 4 - Morphological Adaptations <sup>1</sup> (Provide supporting data in Remarks or on a separate sheet) <input type="checkbox"/> Problematic Hydrophytic Vegetation <sup>1</sup> (Explain)																				
<sup>1</sup> Indicators of hydric soil and wetland hydrology must be present, unless disturbed or problematic.																				
<b>Definitions of Vegetation Strata:</b>  <b>Tree</b> – Woody plants 3 in. (7.6 cm) or more in diameter at breast height (DBH), regardless of height.  <b>Sapling/shrub</b> – Woody plants less than 3 in. DBH and greater than or equal to 3.28 ft (1 m) tall.  <b>Herb</b> – All herbaceous (non-woody) plants, regardless of size, and woody plants less than 3.28 ft tall.  <b>Woody vines</b> – All woody vines greater than 3.28 ft in height.																				
<b>Hydrophytic Vegetation Present?</b>				Yes <input checked="" type="checkbox"/> No <input type="checkbox"/>																

Remarks: (Include photo numbers here or on a separate sheet.)



## WETLAND DETERMINATION DATA FORM – Northcentral and Northeast Region

Project/Site: Grove Street Parcel City/County: Reading Sampling Date: 8/3/22  
 Applicant/Owner: Town of Reading, Engineering Department State: MA Sampling Point: UPL-BVWAZ3  
 Investigator(s): Megan Kearns, PWS Section, Township, Range: \_\_\_\_\_  
 Landform (hillside, terrace, etc.): Hillside Local relief (concave, convex, none): None Slope (%): 1%  
 Subregion (LRR or MLRA): LRR R, MLRA 144A Lat: 42.546961 Long: -71.129381 Datum: WGS84  
 Soil Map Unit Name: Hinckley loamy sand, 3 to 8 percent slopes NWI classification: Upland

Are climatic / hydrologic conditions on the site typical for this time of year? Yes \_\_\_\_\_ No X (If no, explain in Remarks.)  
 Are Vegetation \_\_\_\_\_, Soil \_\_\_\_\_, or Hydrology \_\_\_\_\_ significantly disturbed? Are "Normal Circumstances" present? Yes X No \_\_\_\_\_  
 Are Vegetation \_\_\_\_\_, Soil \_\_\_\_\_, or Hydrology \_\_\_\_\_ naturally problematic? (If needed, explain any answers in Remarks.)

### SUMMARY OF FINDINGS – Attach site map showing sampling point locations, transects, important features, etc.

Hydrophytic Vegetation Present? Yes _____ No <u>X</u> Hydric Soil Present? Yes _____ No <u>X</u> Wetland Hydrology Present? Yes _____ No <u>X</u>	<b>Is the Sampled Area within a Wetland?</b> Yes _____ No _____ If yes, optional Wetland Site ID: _____
Remarks: (Explain alternative procedures here or in a separate report.) Drought recorded.	

### HYDROLOGY

<b>Wetland Hydrology Indicators:</b> <u>Primary Indicators (minimum of one is required; check all that apply)</u> _____ Surface Water (A1) _____ Water-Stained Leaves (B9) _____ High Water Table (A2) _____ Aquatic Fauna (B13) _____ Saturation (A3) _____ Marl Deposits (B15) _____ Water Marks (B1) _____ Hydrogen Sulfide Odor (C1) _____ Sediment Deposits (B2) _____ Oxidized Rhizospheres on Living Roots (C3) _____ Drift Deposits (B3) _____ Presence of Reduced Iron (C4) _____ Algal Mat or Crust (B4) _____ Recent Iron Reduction in Tilled Soils (C6) _____ Iron Deposits (B5) _____ Thin Muck Surface (C7) _____ Inundation Visible on Aerial Imagery (B7) _____ Other (Explain in Remarks) _____ Sparsely Vegetated Concave Surface (B8)	<u>Secondary Indicators (minimum of two required)</u> _____ Surface Soil Cracks (B6) _____ Drainage Patterns (B10) _____ Moss Trim Lines (B16) _____ Dry-Season Water Table (C2) _____ Crayfish Burrows (C8) _____ Saturation Visible on Aerial Imagery (C9) _____ Stunted or Stressed Plants (D1) _____ Geomorphic Position (D2) _____ Shallow Aquitard (D3) _____ Microtopographic Relief (D4) _____ FAC-Neutral Test (D5)
<b>Field Observations:</b> Surface Water Present? Yes _____ No _____ Depth (inches): _____ Water Table Present? Yes _____ No _____ Depth (inches): _____ Saturation Present? Yes _____ No _____ Depth (inches): _____ (includes capillary fringe)	<b>Wetland Hydrology Present?</b> Yes _____ No <u>X</u>
Describe Recorded Data (stream gauge, monitoring well, aerial photos, previous inspections), if available:	
Remarks:	

**VEGETATION** – Use scientific names of plants.

Sampling Point: UPL-BVWA23

	Absolute % Cover	Dominant Species?	Indicator Status																	
<b>Tree Stratum</b> (Plot size: <u>30</u> )																				
1. <u>Acer rubrum</u>	20	Yes	FAC	<b>Dominance Test worksheet:</b>  Number of Dominant Species That Are OBL, FACW, or FAC: <u>2</u> (A)  Total Number of Dominant Species Across All Strata: <u>5</u> (B)  Percent of Dominant Species That Are OBL, FACW, or FAC: <u>40.0%</u> (A/B)																
2. <u>Pinus strobus</u>	40	Yes	FACU																	
3. <u>Quercus rubra</u>	15	Yes	FACU																	
4. _____																				
5. _____																				
6. _____																				
7. _____																				
	<u>75</u>	=Total Cover																		
<b>Sapling/Shrub Stratum</b> (Plot size: <u>15</u> )																				
1. <u>Vaccinium angustifolium</u>	10	Yes	FACU	<b>Prevalence Index worksheet:</b>  <table style="width:100%; border:none;"> <tr> <td style="text-align:right;">Total % Cover of:</td> <td style="text-align:center;">Multiply by:</td> </tr> <tr> <td>OBL species <u>0</u></td> <td>x 1 = <u>0</u></td> </tr> <tr> <td>FACW species <u>0</u></td> <td>x 2 = <u>0</u></td> </tr> <tr> <td>FAC species <u>35</u></td> <td>x 3 = <u>105</u></td> </tr> <tr> <td>FACU species <u>65</u></td> <td>x 4 = <u>260</u></td> </tr> <tr> <td>UPL species <u>0</u></td> <td>x 5 = <u>0</u></td> </tr> <tr> <td>Column Totals: <u>100</u> (A)</td> <td><u>365</u> (B)</td> </tr> <tr> <td colspan="2" style="text-align:center;">Prevalence Index = B/A = <u>3.65</u></td> </tr> </table>	Total % Cover of:	Multiply by:	OBL species <u>0</u>	x 1 = <u>0</u>	FACW species <u>0</u>	x 2 = <u>0</u>	FAC species <u>35</u>	x 3 = <u>105</u>	FACU species <u>65</u>	x 4 = <u>260</u>	UPL species <u>0</u>	x 5 = <u>0</u>	Column Totals: <u>100</u> (A)	<u>365</u> (B)	Prevalence Index = B/A = <u>3.65</u>	
Total % Cover of:	Multiply by:																			
OBL species <u>0</u>	x 1 = <u>0</u>																			
FACW species <u>0</u>	x 2 = <u>0</u>																			
FAC species <u>35</u>	x 3 = <u>105</u>																			
FACU species <u>65</u>	x 4 = <u>260</u>																			
UPL species <u>0</u>	x 5 = <u>0</u>																			
Column Totals: <u>100</u> (A)	<u>365</u> (B)																			
Prevalence Index = B/A = <u>3.65</u>																				
2. <u>Clethra alnifolia</u>	15	Yes	FAC																	
3. _____																				
4. _____																				
5. _____																				
6. _____																				
7. _____																				
	<u>25</u>	=Total Cover																		
<b>Herb Stratum</b> (Plot size: <u>5</u> )																				
1. _____				<b>Hydrophytic Vegetation Indicators:</b> <u>1</u> - Rapid Test for Hydrophytic Vegetation <u>2</u> - Dominance Test is >50% <u>3</u> - Prevalence Index is ≤3.0 <sup>1</sup> <u>4</u> - Morphological Adaptations <sup>1</sup> (Provide supporting data in Remarks or on a separate sheet) <u>  </u> Problematic Hydrophytic Vegetation <sup>1</sup> (Explain)  <sup>1</sup> Indicators of hydric soil and wetland hydrology must be present, unless disturbed or problematic.																
2. _____																				
3. _____																				
4. _____																				
5. _____																				
6. _____																				
7. _____																				
8. _____																				
9. _____																				
10. _____																				
11. _____																				
12. _____																				
<b>Woody Vine Stratum</b> (Plot size: <u>15</u> )																				
1. _____				<b>Definitions of Vegetation Strata:</b>  <b>Tree</b> – Woody plants 3 in. (7.6 cm) or more in diameter at breast height (DBH), regardless of height.  <b>Sapling/shrub</b> – Woody plants less than 3 in. DBH and greater than or equal to 3.28 ft (1 m) tall.  <b>Herb</b> – All herbaceous (non-woody) plants, regardless of size, and woody plants less than 3.28 ft tall.  <b>Woody vines</b> – All woody vines greater than 3.28 ft in height.																
2. _____																				
3. _____																				
4. _____																				
				<b>Hydrophytic Vegetation Present?</b> Yes <u>  </u> No <u>  X  </u>																

Remarks: (Include photo numbers here or on a separate sheet.)



## **APPENDIX B**

### Site Photographs



**Photo 1:** View of Grove Street Parcel facing north from Grove Street. A walking trail can be seen entering the parcel.



**Photo 2:** View of BVW Series A from flag BVW-A1.



**Photo 3:** View of BVW Series A from flag BVW-A6.



**Photo 4:** View of BVW Series A from flag BVW-A23.

## APPENDIX C



**Legend**

-  Wetland Flags
-  Wetland Lines
-  Limit of Work
-  Marsh/Bog
-  Wooded marsh
-  Cranberry Bog
-  Salt Marsh
-  Open Water
-  Reservoir (with PWSID)
-  Tidal Flats
-  Beach/Dune
-  MA Towns
-  Parcel
-  Parcel

**FIGURE 1**

Grove Street Parcel  
Reading, MA

Delineation Map

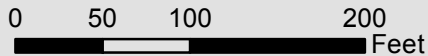
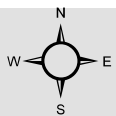

Data Source: Office of Geographic and Environmental Information (MassGIS),  
Commonwealth of Massachusetts Executive Office of Environmental Affairs



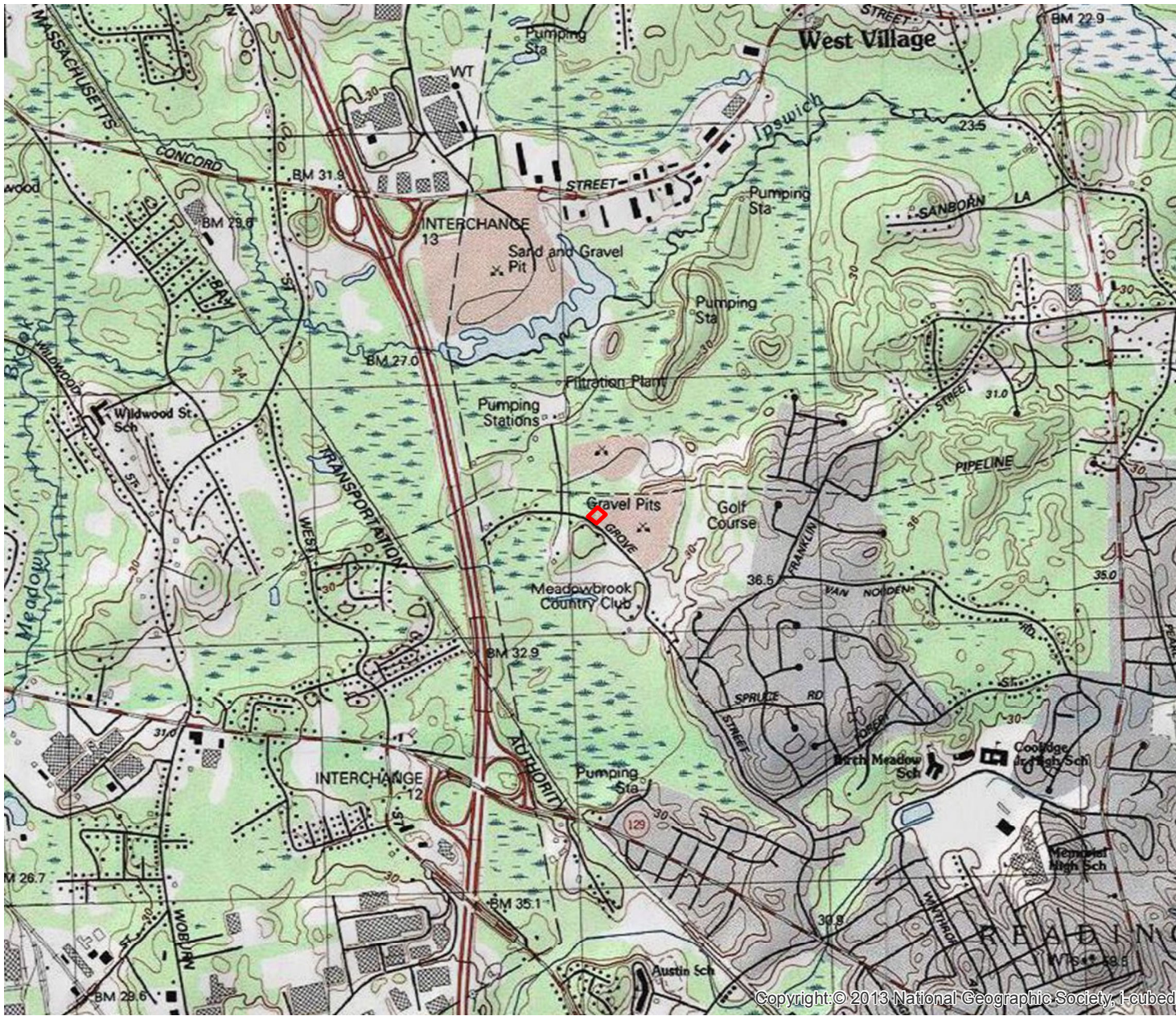

## Legend

 Limit of Work

**FIGURE 2**

Grove Street Parcel  
Reading, MA

USGS Map

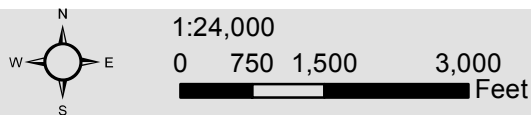

Data Source: Office of Geographic and Environmental Information (MassGIS),  
Commonwealth of Massachusetts Executive Office of Environmental Affairs

Weston & Sampson<sup>SM</sup>

# National Flood Hazard Layer FIRMette

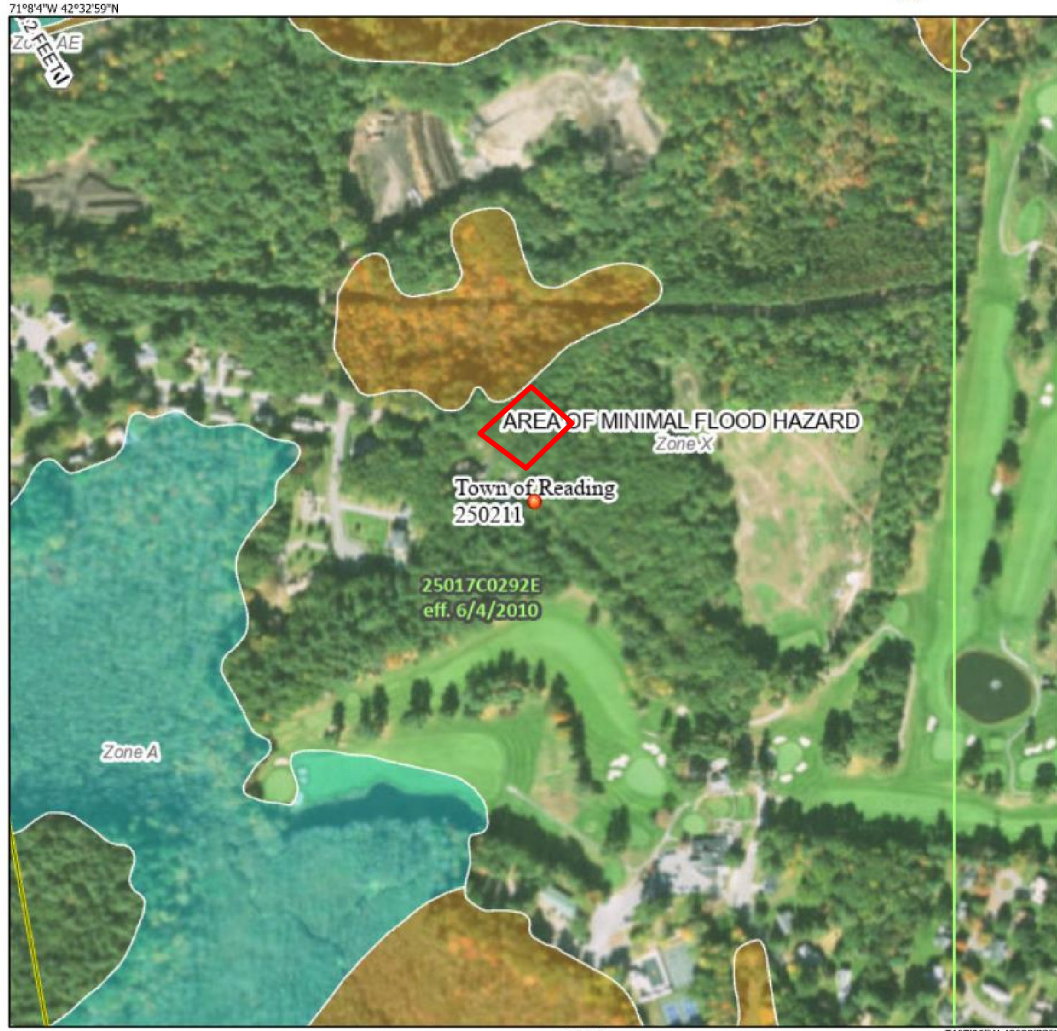

0 250 500 1,000 1,500 2,000 Feet 1:6,000  
 Basemap: USGS National Map; Orthoimagery: Data refreshed October, 2020

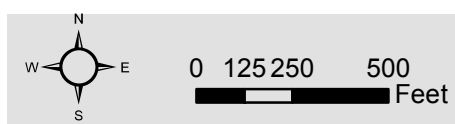

Data Source: Office of Geographic and Environmental Information (MassGIS), Commonwealth of Massachusetts Executive Office of Environmental Affairs

## Legend

- SEE FIS REPORT FOR DETAILED LEGEND AND INDEX MAP FOR FIRM PANEL LAYOUT
- SPECIAL FLOOD HAZARD AREAS**
    - Without Base Flood Elevation (BFE) Zone A, V, A99
    - With BFE or Depth Zone AE, AO, AH, VE, AR
    - Regulatory Floodway
  - OTHER AREAS OF FLOOD HAZARD**
    - 0.2% Annual Chance Flood Hazard, Areas of 1% annual chance flood with average depth less than one foot or with drainage areas of less than one square mile. Zone X
    - Future Conditions 1% Annual Chance Flood Hazard Zone X
    - Area with Reduced Flood Risk due to Levee. See Notes. Zone X
    - Area with Flood Risk due to Levee Zone D
  - OTHER AREAS**
    - NO SCREEN Area of Minimal Flood Hazard Zone X
    - Effective LOMRs
    - Area of Undetermined Flood Hazard Zone D
  - GENERAL STRUCTURES**
    - Channel, Culvert, or Storm Sewer
    - Levee, Dike, or Floodwall
  - OTHER FEATURES**
    - Cross Sections with 1% Annual Chance Water Surface Elevation
    - Coastal Transect
    - Base Flood Elevation Line (BFE)
    - Limit of Study
    - Jurisdiction Boundary
    - Coastal Transect Baseline
    - Profile Baseline
    - Hydrographic Feature
  - MAP PANELS**
    - Digital Data Available
    - No Digital Data Available
    - Unmapped
- The pin displayed on the map is an approximate point selected by the user and does not represent an authoritative property location.

## Legend

Limit of Work

This map complies with FEMA's standards for the use of digital flood maps if it is not void as described below. The basemap shown complies with FEMA's basemap accuracy standards

The flood hazard information is derived directly from the authoritative NFHL web services provided by FEMA. This map was exported on 10/31/2022 at 2:41 PM and does not reflect changes or amendments subsequent to this date and time. The NFHL and effective information may change or become superseded by new data over time.

This map image is void if the one or more of the following map elements do not appear: basemap imagery, flood zone labels, legend, scale bar, map creation date, community identifiers, FIRM panel number, and FIRM effective date. Map images for unmapped and unmapped areas cannot be used for regulatory purposes.

FIGURE 3

























Grove Street Parcel  
 Reading, MA

FEMA FIRM Map





### Legend

-  Wetland Lines
-  Limit of Work
-  Hydrologic Connection
-  Perennial Stream
-  Intermittent Stream
-  Marsh/Bog
-  Wooded marsh
-  Cranberry Bog
-  Salt Marsh
-  Open Water
-  Reservoir (with PWSID)
-  Tidal Flats
-  Beach/Dune
-  MA Towns
-  Parcel
-  Parcel
- ACECs**
-  ACECs
- NHESP Habitats**
-  NHESP Estimated Habitats of Rare Wildlife
-  NHESP Priority Habitats of Rare Species
-  NHESP Certified Vernal Pools
-  NHESP Potential Vernal Pools
-  Cold Water Fisheries
- Outstanding Resource Waters**
-  Public Water Supply Contributor
-  ORW for ACEC
-  ORW for both Water Supply and Other

**FIGURE 4**

Grove Street Parcel  
Reading, MA

Environmental  
Constraints Map

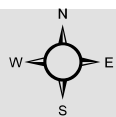

0 50 100 200  
Feet

Data Source: Office of Geographic and Environmental Information (MassGIS),  
Commonwealth of Massachusetts Executive Office of Environmental Affairs



## APPENDIX D

# TOWN OF READING, MASSACHUSETTS

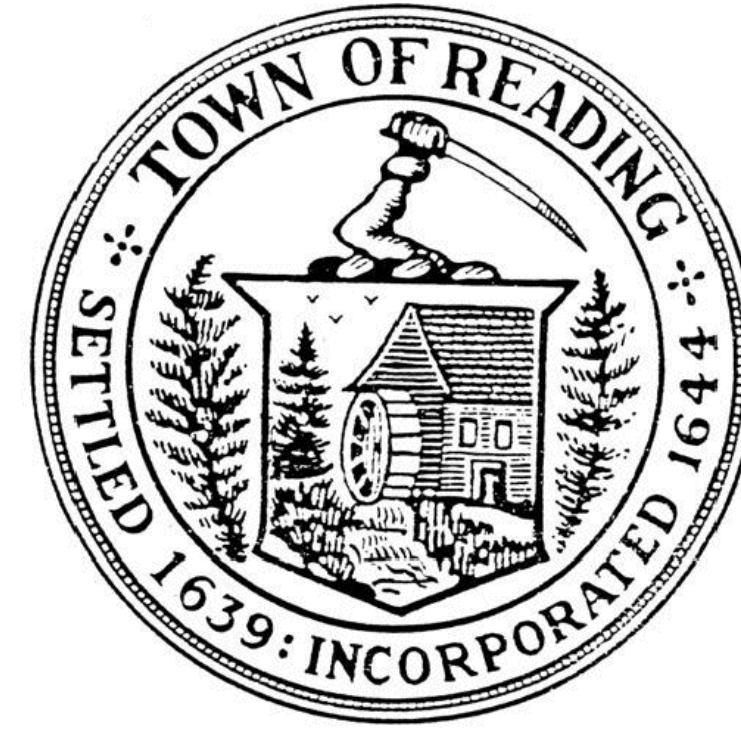

## GROVE STREET, LOT 5 PARKING LOT READING, MASSACHUSETTS 01867

### DRAWING INDEX

SHEET	TITLE
C001	ABBREVIATIONS, NOTES & LEGEND
C100	EXISTING CONDITIONS PLAN
CD100	SITE PREPARATION & EROSION CONTROL PLAN
C101	LAYOUT & MATERIALS PLAN
C102	GRADING PLAN
C500	CONSTRUCTION DETAILS
C501	CONSTRUCTION DETAILS

### ZONING INFORMATION

PARCEL ID:	044.0-0000-0024.0
ADDRESS:	0 GROVE STREET
OWNER:	TOWN OF READING 16 LOWELL STREET READING, MA 00867
ZONING DISTRICTS:	S20
EXISTING USE:	UNDEVELOPED
PROPOSED USE:	OUTDOOR RECREATION / CONSERVANCY



LOCUS MAP  
SCALE : 1"=200'

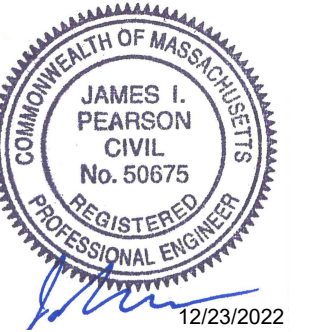

**Weston & Sampson**

Weston & Sampson Engineers, Inc.  
55 Walkers Brook Drive, Suite 100  
Reading, MA 01867  
978.532.1900 800.SAMPSON  
[www.westonandsampson.com](http://www.westonandsampson.com)

Issued Date:

**DECEMBER 23, 2022**



Know what's below.  
Call before you dig.

Issued For:

**PERMITTING - NOT FOR CONSTRUCTION**











**NOTES:**

1. PROVIDE A MINIMUM TUBE DIAMETER OF 12 INCHES FOR SLOPES UP TO 50 FEET IN LENGTH WITH A SLOPE RATIO OF 3H:1V OR STEEPER. LONGER SLOPES OF 3H:1V MAY REQUIRE LARGER TUBE DIAMETER OR ADDITIONAL COURSING OF FILTER TUBES TO CREATE A FILTER BERM. REFER TO MANUFACTURER'S RECOMMENDATIONS FOR SITUATIONS WITH LONGER OR STEEPER SLOPES.
2. INSTALL TUBES ALONG CONTOURS AND PERPENDICULAR TO SHEET OR CONCENTRATED FLOW.
3. DO NOT INSTALL IN PERENNIAL, EPHEMERAL OR INTERMITTENT STREAMS.
4. CONFIGURE TUBES AROUND EXISTING SITE FEATURES TO MINIMIZE SITE DISTURBANCE AND MAXIMIZE CAPTURE AREA OF STORMWATER RUN-OFF.
5. MULCH MATERIAL FOR THE FILTER TUBES SHALL BE WEED-FREE STRAW, WOOD EXCELSIOR, COMPOST, OR WOOD CHIPS, OR COIR. STRAW SHALL BE WEED FREE AND DERIVED FROM THRESHING OF GRAIN CROP.

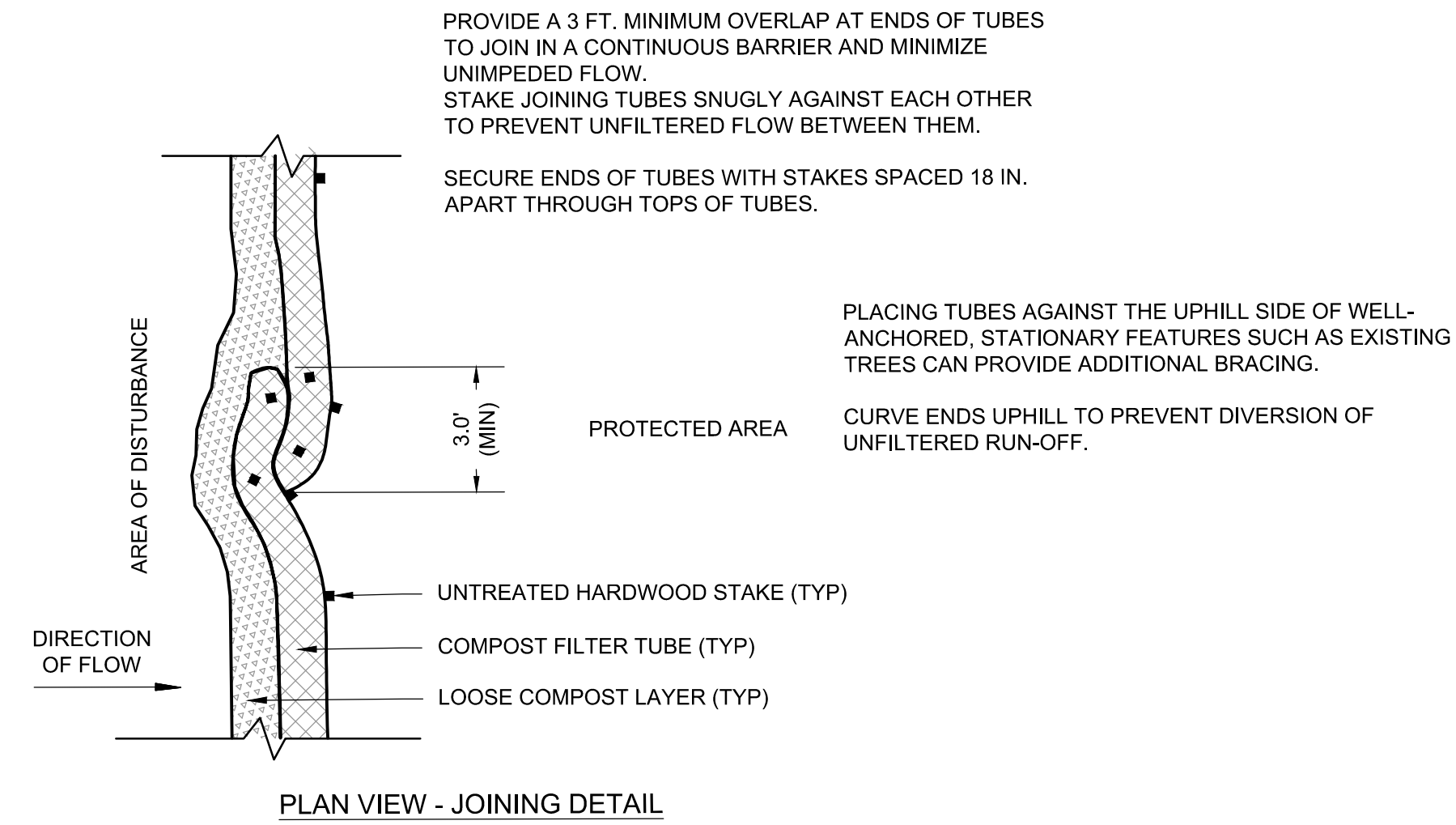

PLAN VIEW - JOINING DETAIL

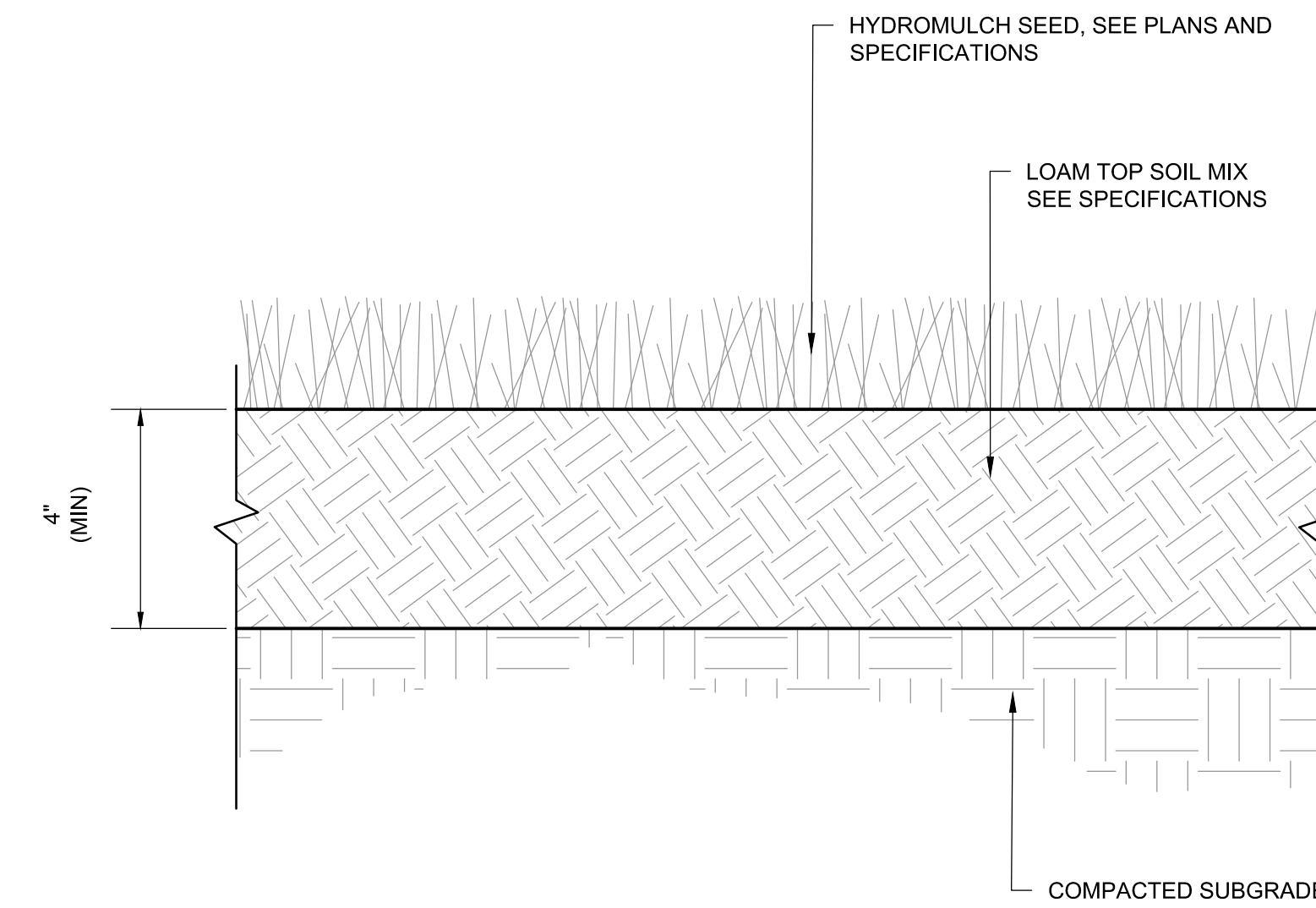

2 LOAM & SEED

SCALE: N.T.S.

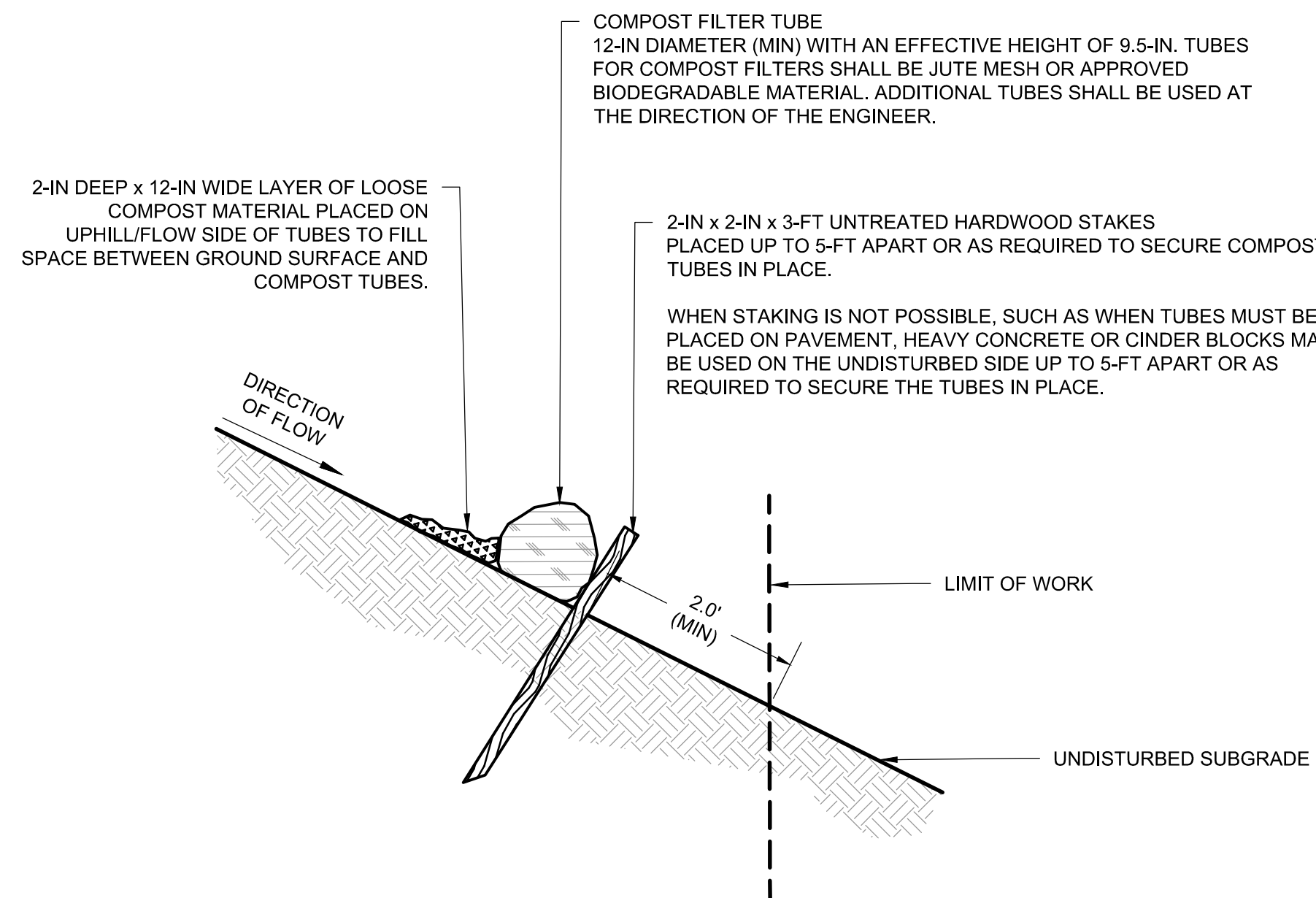

1 COMPOST FILTER TUBE

SCALE: N.T.S.

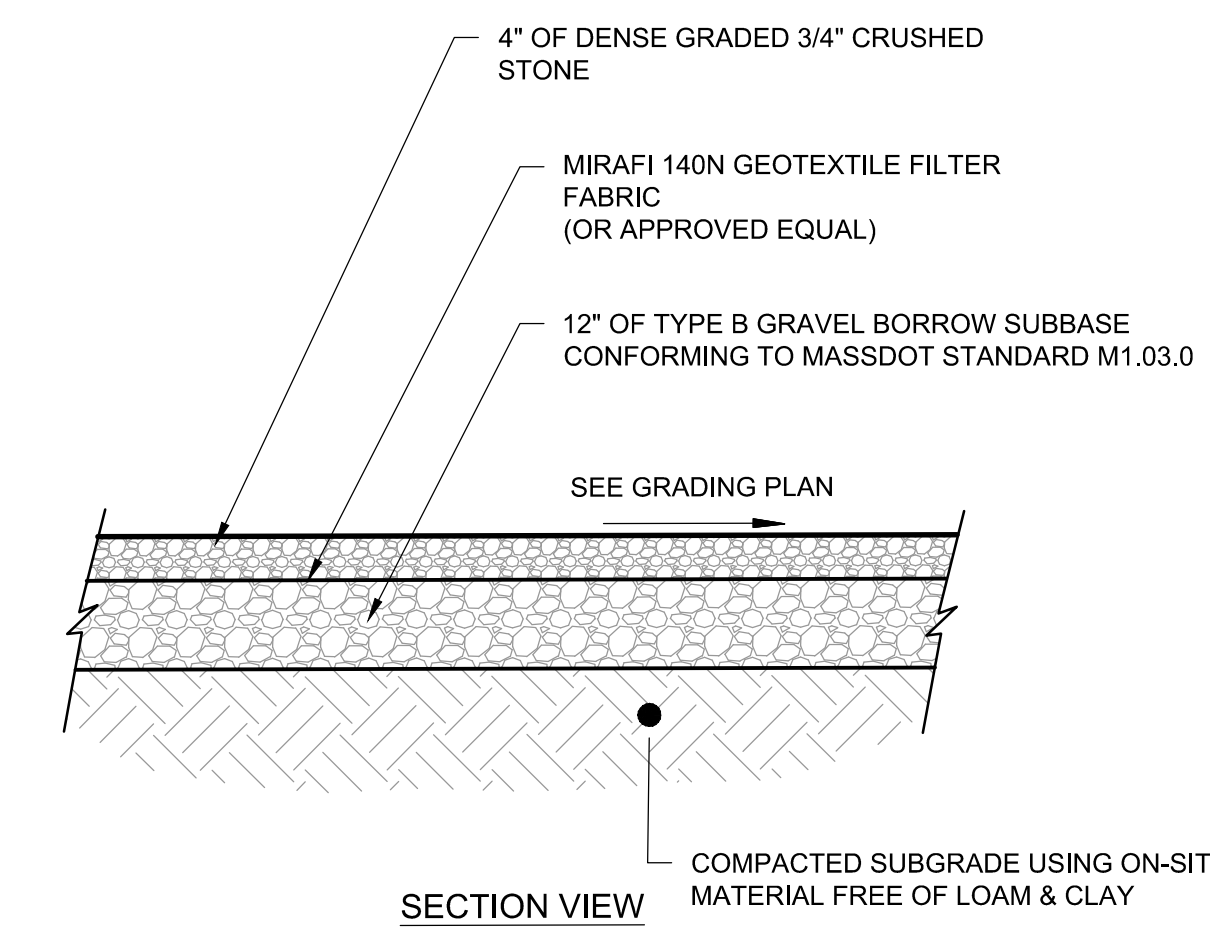

3 GRAVEL SURFACE TREATMENT

SCALE: N.T.S.

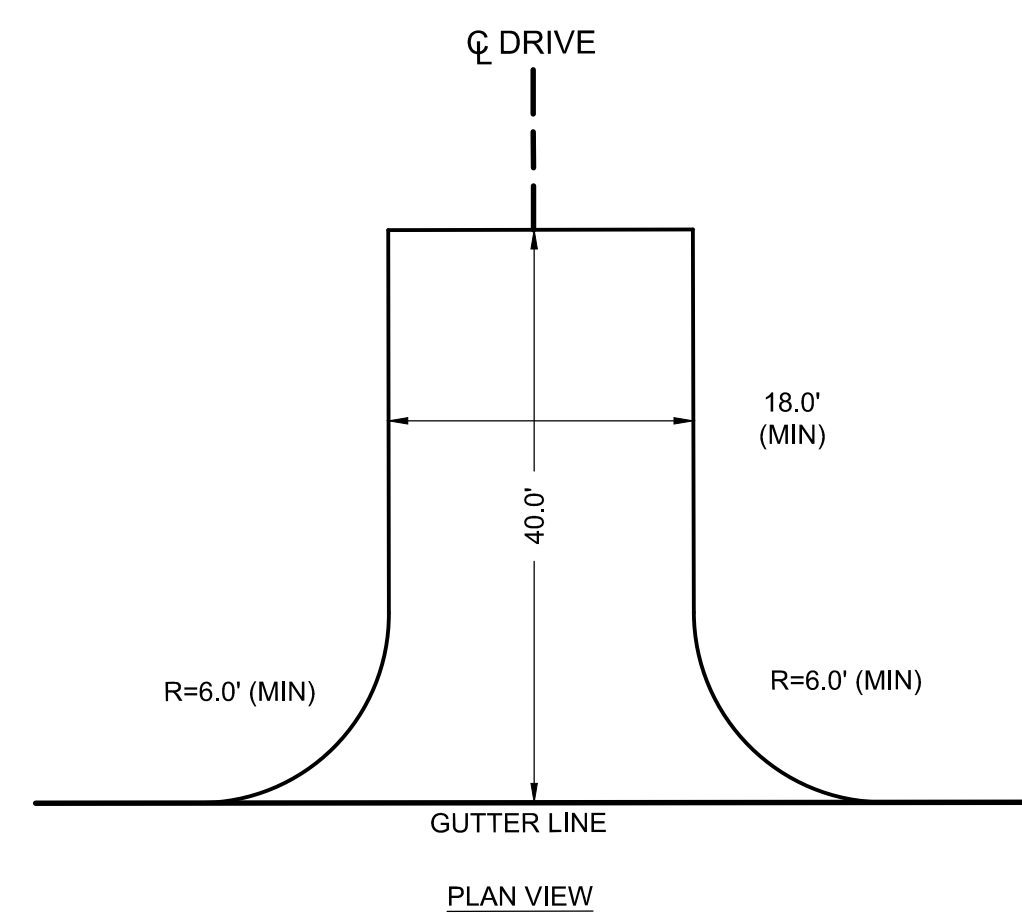

**NOTES:**

1. THE LOCATION OF THE CONSTRUCTION ENTRANCE SHALL BE APPROVED BY THE OWNER PRIOR TO PLACEMENT.
2. CONSTRUCTION ENTRANCE SHALL CONSIST OF 2\"/>

4 STABILIZED TEMPORARY CONSTRUCTION ENTRANCE

SCALE: N.T.S.

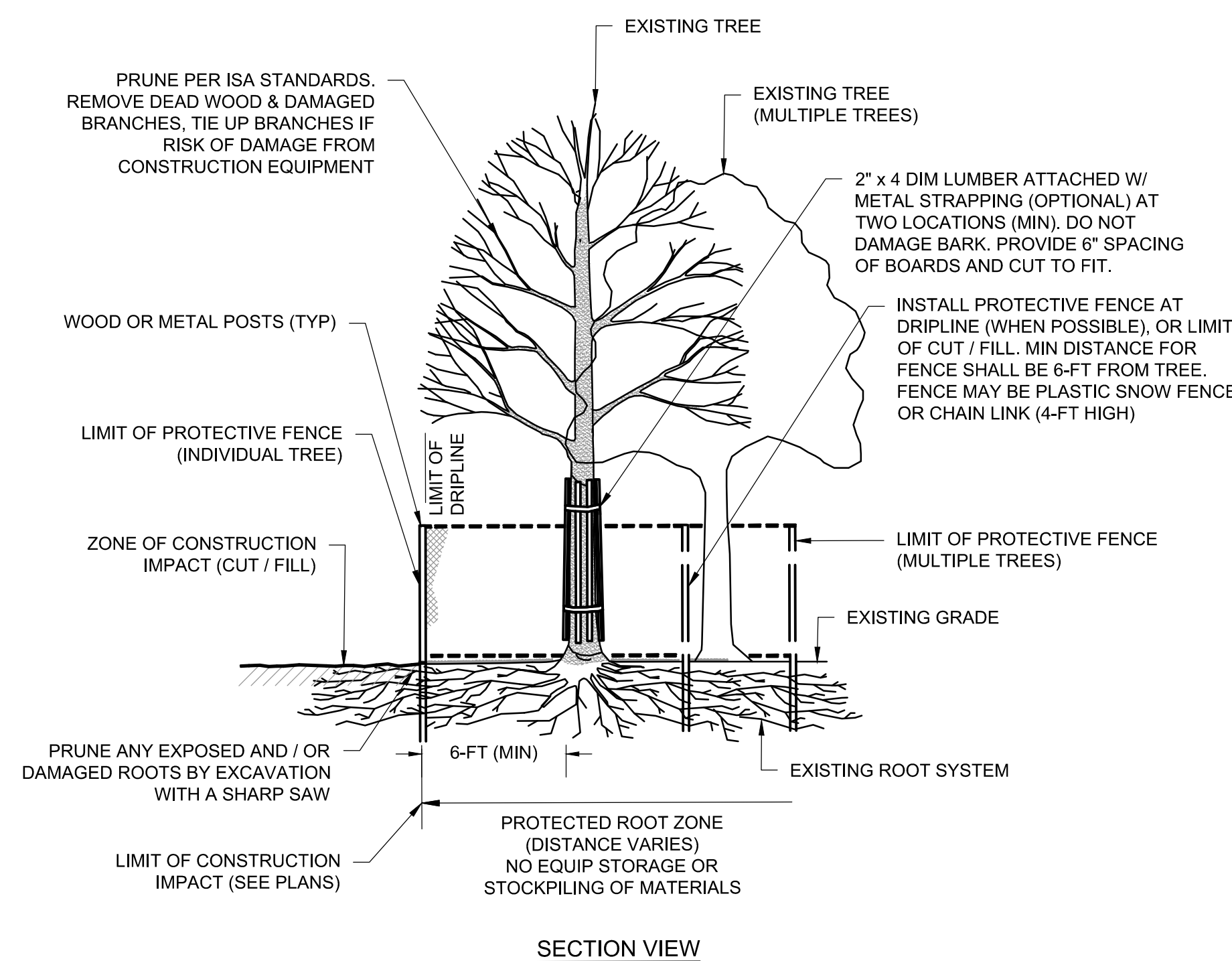

SECTION VIEW

5 TYPICAL TREE PROTECTION

SCALE: N.T.S.

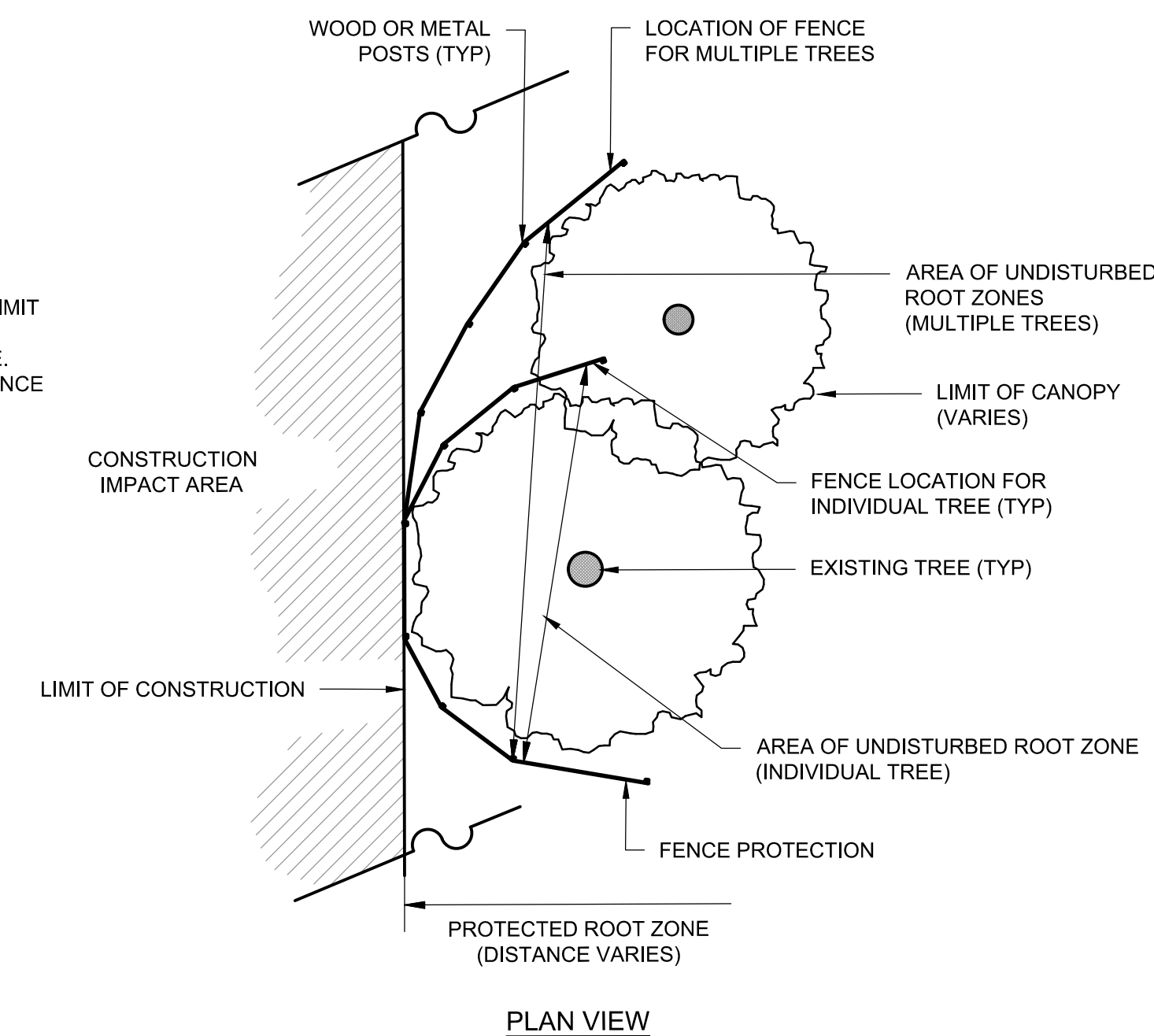

PLAN VIEW

Revisions:

No.	Date	Description

COA:  
COPYRIGHT © 2022 BY WESTON & SAMPSON.  
THIS DRAWING HAS BEEN PREPARED FOR THE EXCLUSIVE USE OF THE CLIENT & PROJECT NAME LISTED ON THIS DRAWING ONLY.  
REPRODUCTION, RELEASE OF UTILIZATION OF THE DRAWING CONTENT BY OTHER CLIENTS / FIRMS AND ON OTHER PROJECTS IS PROHIBITED BY LAW.  
WESTON & SAMPSON RETAINS THE EXCLUSIVE USE OF THE INTELLECTUAL PROPERTY CONTAINED HEREIN.

Seal:  
  
12/23/2022

Issued For:  
**PERMITTING - NOT FOR CONSTRUCTION**

Scale: AS SHOWN

Date: DECEMBER 23, 2022  
Drawn By: AKG  
Reviewed By: JIP  
Approved By: JIP  
W&S Project No.: ENG22-0527  
W&S File No.:

Drawing Title:  
**CONSTRUCTION DETAILS**

Sheet Number:  
**C500**

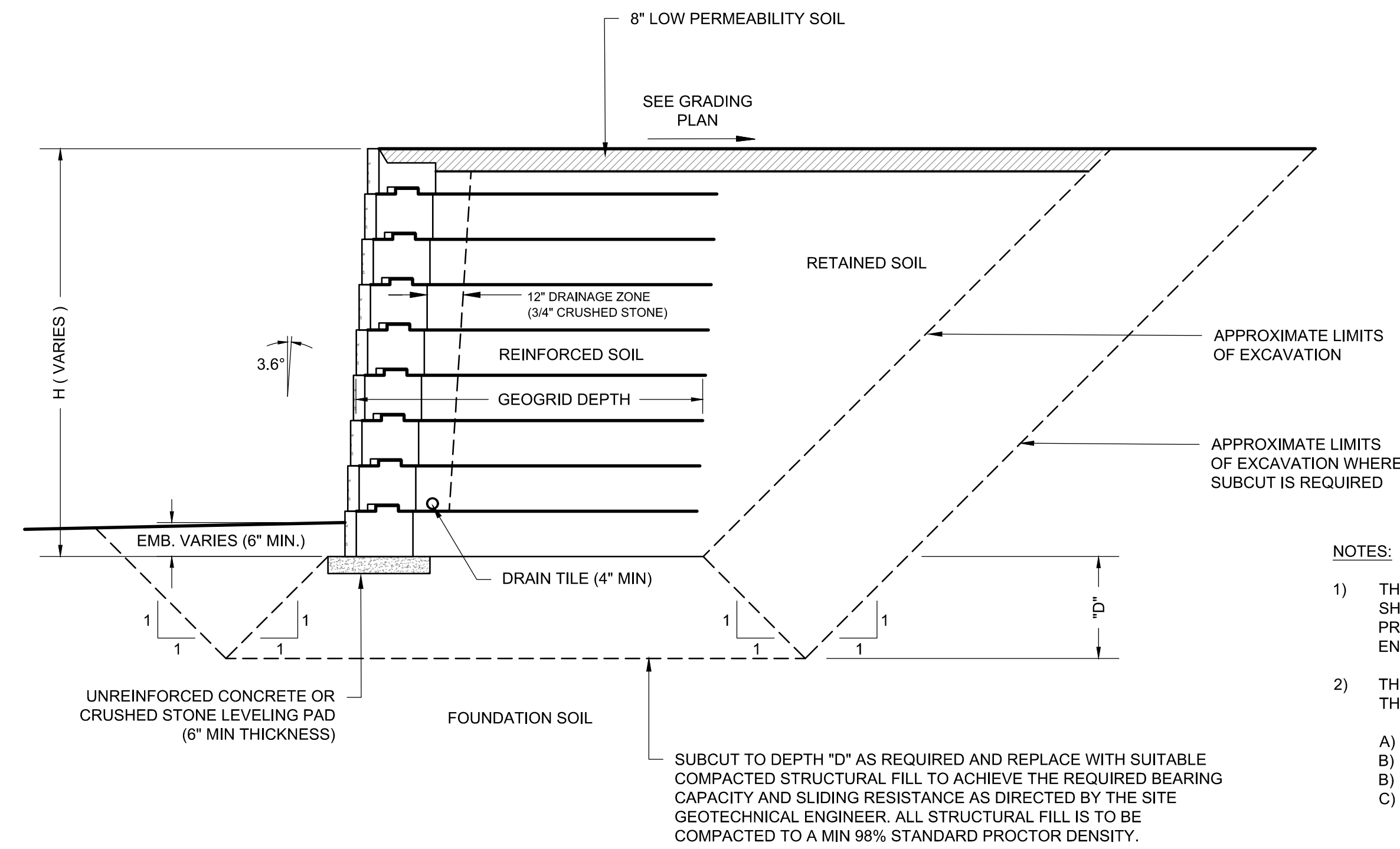

**1 TYPICAL RETAINING WALL CROSS-SECTION**  
SCALE: N.T.S.

- NOTES:**
- THIS TYPICAL DETAIL IS SHOWN FOR ILLUSTRATIVE PURPOSES. THE CONTRACTOR SHALL SUBMIT RETAINING WALL / GEOGRID DESIGNS STAMPED BY A REGISTERED PROFESSIONAL ENGINEER. THE SUBMITTAL MUST BE APPROVED BY THE DESIGN ENGINEER PRIOR TO CONSTRUCTION.
  - THE RETAINING WALL DESIGN CRITERIA SHALL INCLUDE (BUT NOT BE LIMITED TO) THE FOLLOWING:
    - EFFECTS OF LATERAL EARTH PRESSURE
    - SURCHARGE FROM SNOW STORAGE AT THE TOP OF THE WALL
    - SURCHARGE FROM VEHICLE LOADING AT THE TOP OF THE WALL (H=20 MINIMUM)
    - EFFECTS OF SOIL SATURATION DUE TO GROUNDWATER, SNOWMELT OR STORMWATER RECHARGE SYSTEMS
  - RETAINING WALL MATERIAL SHALL BE PRECAST CONCRETE BLOCKS AND ARE INTENDED TO RESEMBLE NATURAL STONE WALLS

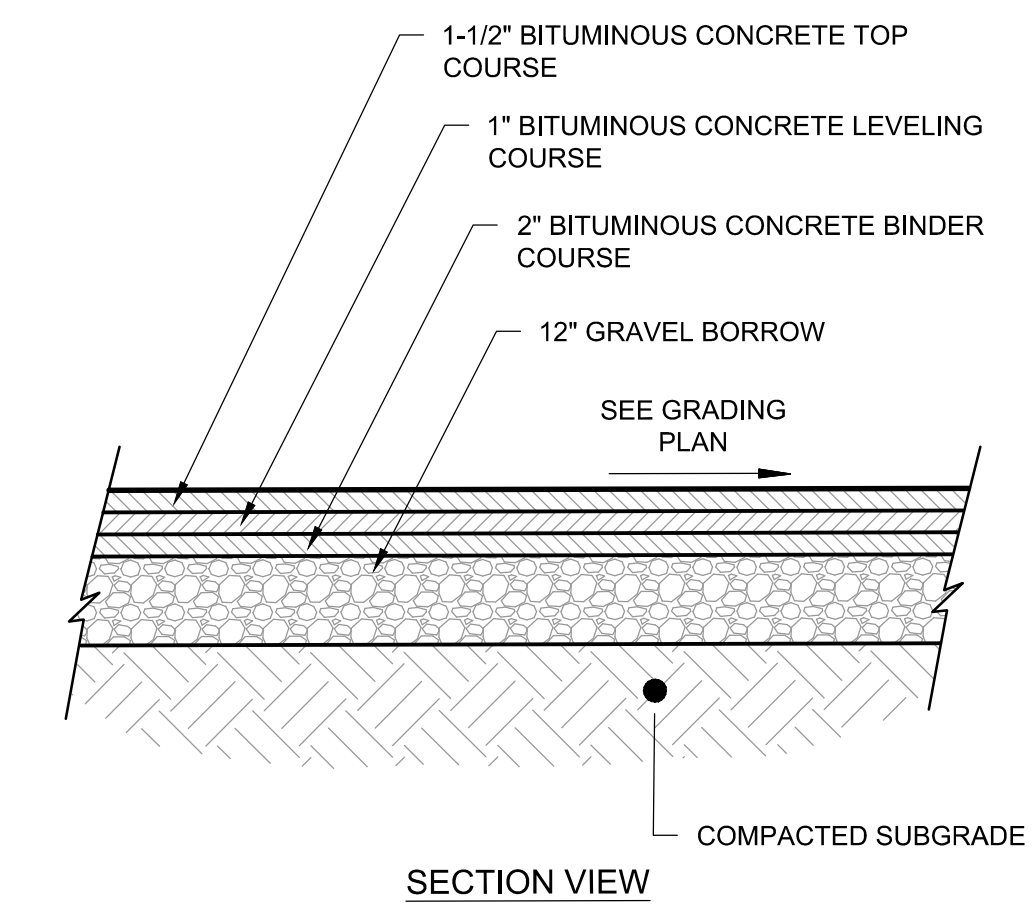

**2 BITUMINOUS CONCRETE PAVEMENT**  
SCALE: N.T.S.

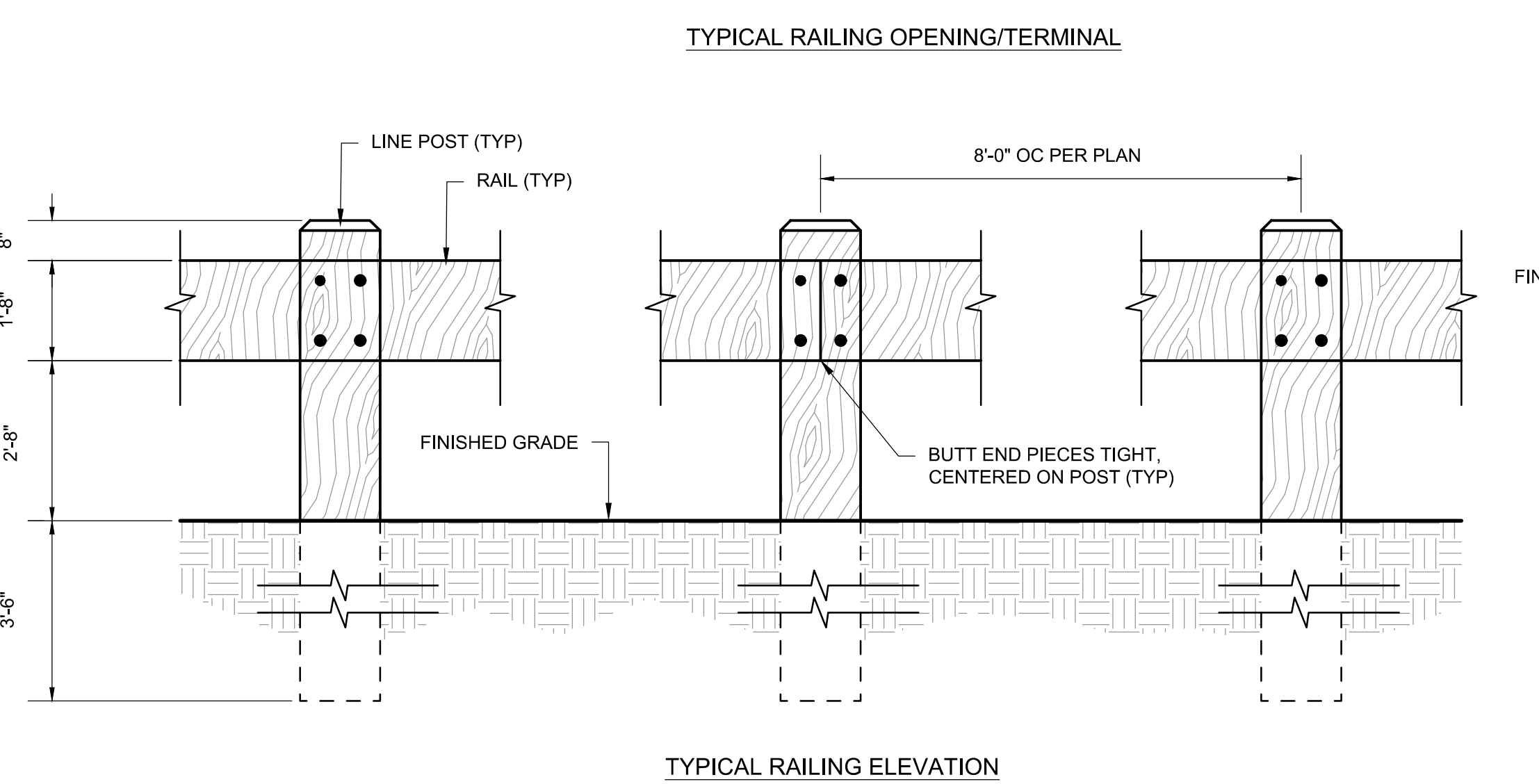
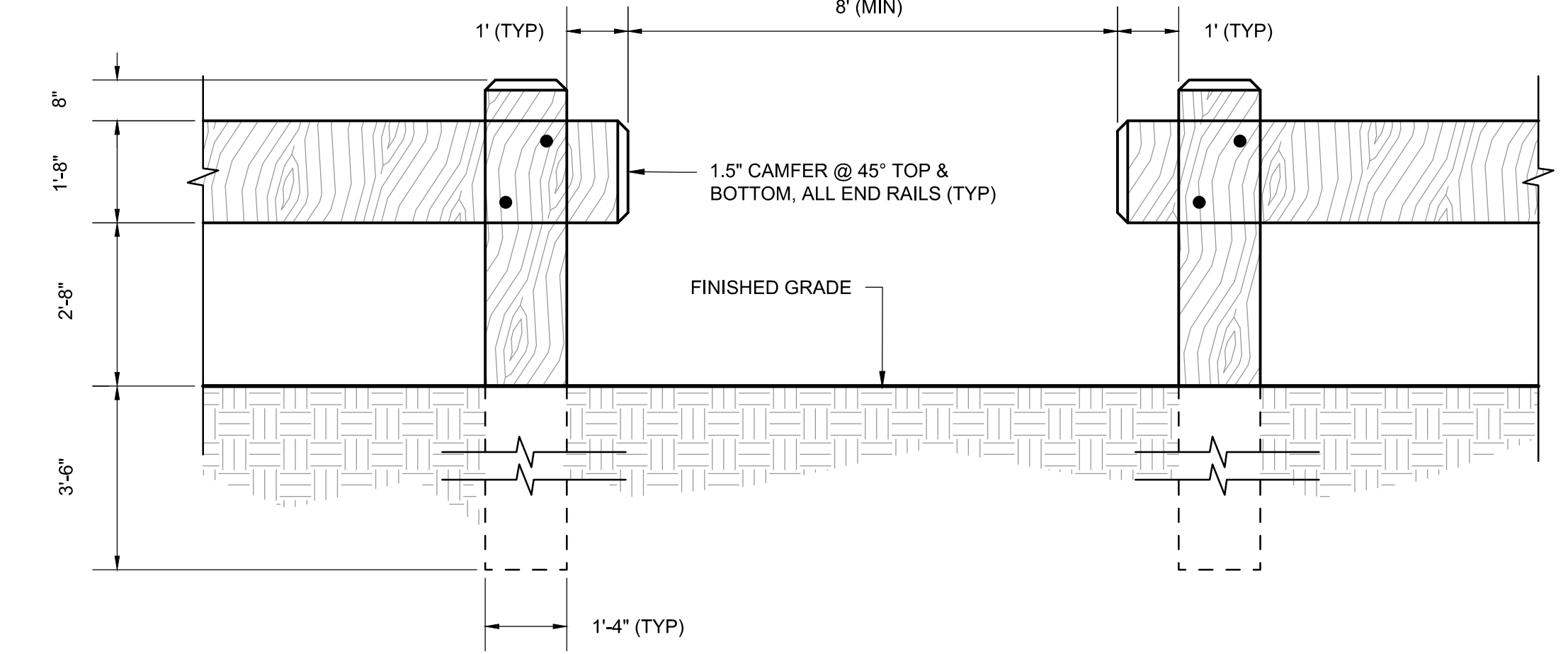

**3 WOODEN GUARDRAIL**  
SCALE: N.T.S.

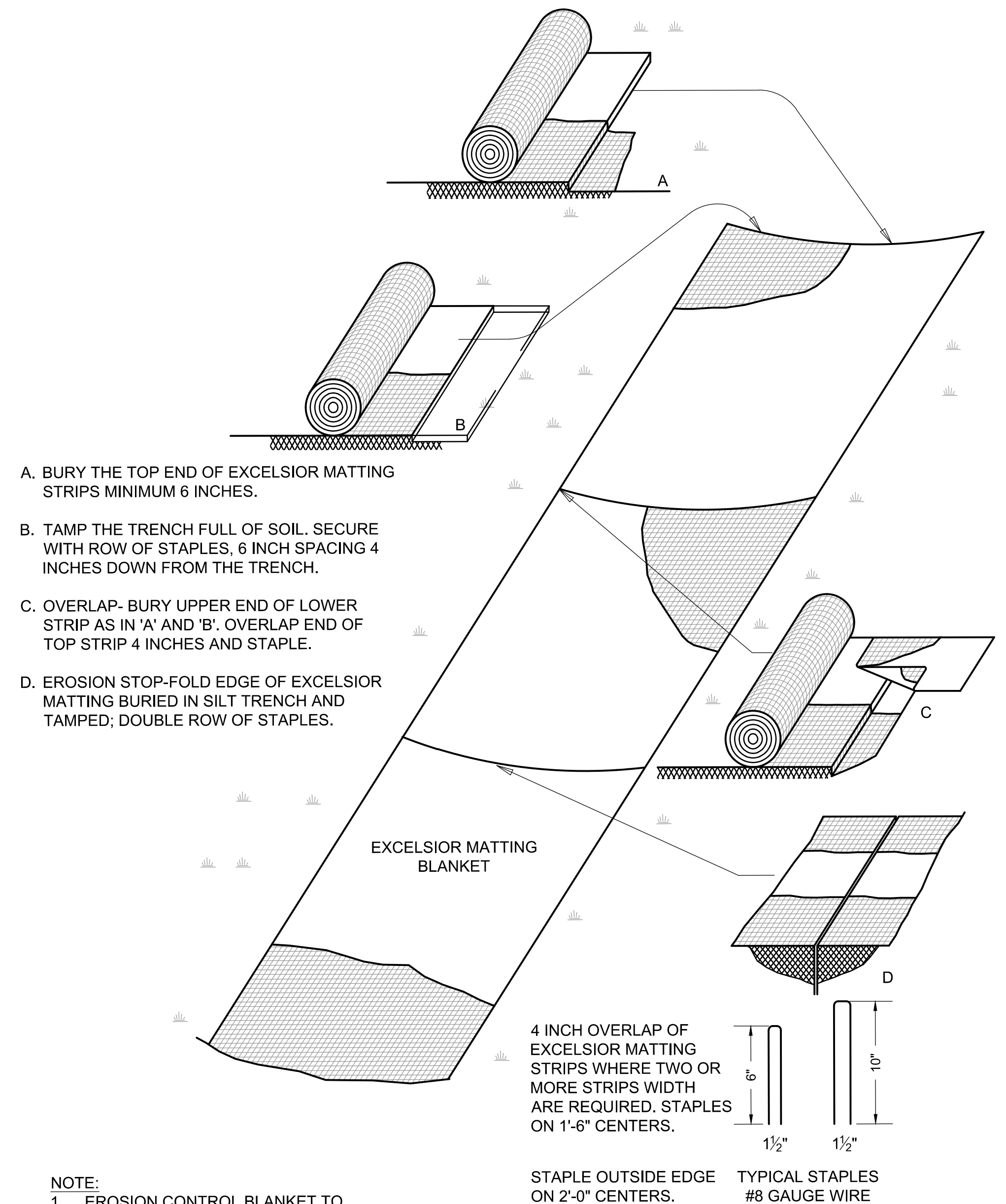

- NOTE:**
- EROSION CONTROL BLANKET TO BE USED ON ALL SLOPES GREATER THAN 2.5H:1V AS INDICATED ON GRADING PLANS.

**4 EROSION CONTROL BLANKET**  
SCALE: N.T.S.

Consultants:

No.	Date	Description

Revisions:

No.	Date	Description

COA:  
COPYRIGHT © 2022 BY WESTON & SAMPSON.  
THIS DRAWING HAS BEEN PREPARED FOR THE EXCLUSIVE USE OF THE CLIENT & PROJECT NAME LISTED ON THIS DRAWING ONLY.  
REPRODUCTION, RELEASE OF UTILIZATION OF THE DRAWING CONTENT BY OTHER CLIENTS / FIRMS AND ON OTHER PROJECTS IS PROHIBITED BY LAW.  
WESTON & SAMPSON RETAINS THE EXCLUSIVE USE OF THE INTELLECTUAL PROPERTY CONTAINED HEREIN.

Seal:

Issued For:  
**PERMITTING - NOT FOR CONSTRUCTION**

Scale: AS SHOWN

Date: DECEMBER 23, 2022  
Drawn By: AKG  
Reviewed By: JIP  
Approved By: JIP  
W&S Project No.: ENG22-0527  
W&S File No.:

Drawing Title:  
**CONSTRUCTION DETAILS**

Sheet Number:  
**C501**