

**PROJECT NOTES:**

- LOCATION: 135, 139 & 149R HOWARD STREET  
(MAP 10 - LOTS 75 (#135), 76 (#139) - & 77 (#149R))
- PROPERTY REFERENCES: SOUTH MIDDLESEX REGISTRY OF DEEDS  
BOOK 47898 PAGE 406 (#135)  
BOOK 44847 PAGE 383 (#139)  
BOOK 71028 PAGE 115 (#149R)
- ZONE: S15
- USE: SINGLE FAMILY RESIDENTIAL
- OWNERS: KEVIN GREENWOOD (#135 & #149R)  
KEVIN GREENWOOD & JAMES DOHERTY (#139)
- APPLICANT: INFRASTRUCTURE HOLDINGS, LLC  
122 BOSTON ROAD  
BILLERICA, MA 01862  
TEL: (978) 256-0770
- LAND SURVEYOR: SEC & ASSOCIATES  
185 PLAISTOW ROAD - UNIT 2  
PLAISTOW, NH 03865  
TEL: (603) 382-5065
- SOILS / WETLANDS: NORSE ENVIRONMENTAL SERVICES, INC.  
92 MIDDLESEX ROAD - UNIT 4  
TYNGSBORO, MA 01879
- ALL INFORMATION AS SHOWN WAS PRODUCED FROM TOWN OF READING ASSESSORS INFORMATION, THE SOUTH MIDDLESEX REGISTRY OF DEEDS OF DEEDS, LIDAR DATA, AN ON GROUND SURVEY BY SEC & ASSOCIATES OF PLAISTOW, NH IN AUGUST OF 2018, AND AN AERIAL SURVEY BY CIVILVIEW, INC. IN DECEMBER OF 2018.
- ALL ELEVATIONS REFER TO THE NORTH AMERICAN VERTICAL DATUM (NAVD88).
- PLAN BEARINGS ARE BASED UPON THE MASSACHUSETTS STATE PLANE COORDINATE SYSTEM (NAD83), MAINLAND ZONE.
- PROPERTY IS LOCATED WITHIN A ZONE X, AREAS DETERMINED TO BE OUTSIDE THE 0.2% ANNUAL CHANCE FLOODPLAIN AS SHOWN ON FLOOD INSURANCE RATE MAP NUMBER 25017C00313E PANEL 313 OF 656 EFFECTIVE DATE JUNE 4, 2010.
- WETLANDS WERE DELINEATED BY NORSE ENVIRONMENTAL SERVICES, INC. OF TYNGSBORO ON AUGUST 20, 2018.
- THIS PLAN SET HAS BEEN PREPARED TO ADDRESS THE CONTENT REQUIREMENTS OF SECTION 6.0 (DEFINITIVE PLANS) OF THE TOWN OF READING SUBDIVISION REGULATIONS. IT IS INTENDED TO BE ACCEPTED AS A PUBLIC WAY IN THE TOWN OF READING.
- THE FOLLOWING WAIVERS ARE BEING REQUESTED FROM THE TOWN OF READING COMMUNITY PLANNING AND DEVELOPMENT COMMISSION SUBDIVISION REGULATIONS REVISED THROUGH AUGUST 26, 2006:  
**WAIVER #1:** 6.1.1.D.3 - WAIVER FROM A FULL TRAFFIC STUDY.  
**WAIVER #2:** 7.1.3 - WAIVER FROM "TYPICAL CROSS SECTION FOR A SIXTY-FOOT STREET" TO ALLOW FOR THE REDUCTION IN PAVEMENT WIDTH FROM 30' TO 24' AND THE REMOVAL OF SIDEWALKS.  
**WAIVER #3:** 7.1.5.E - WAIVER FROM THE CUL-DE-SAC LANDSCAPED ISLAND  
**WAIVER #4:** 7.2 - WAIVER FROM THE REQUIREMENT FOR SIDEWALKS.  
**WAIVER #5:** 7.4 - WAIVER FROM THE WATER MAIN BEING PLACED HIGHER THAN ANY OTHER LINE.  
**WAIVER #6:** 7.4.1 - WAIVER FROM A LOOPED WATER MAIN.  
**WAIVER #7:** 7.4.2 - WAIVER FROM DESIGN STANDARDS TO ALLOW FOR A SEWER FORCE MAIN.  
**WAIVER #8:** 7.4.4.3.E - WAIVER FROM DESIGN STANDARDS TO ALLOW FOR A DRAIN PIPE WITH 1.9% OF COVER WITHIN THE PAVED ROADWAY.
- ALL WATER AND SEWER CONSTRUCTION ACTIVITIES SHALL BE PERFORMED BY A LICENSED TOWN DRAIN LAYER AND SUPERVISED BY THE TOWN OF READING WATER DIVISION. ALL TESTING RESULTS FOR THE UTILITIES AND SERVICE TIE CARDS ARE REQUIRED TO BE SUBMITTED TO THE TOWN DPW ENGINEERING DIVISION.
- CONTRACTOR SHALL SECURE A STREET OPENING PERMIT, A TRENCH PERMIT, A SEWER AND WATER MAIN & SERVICE PERMIT FOR UTILITY CONSTRUCTION, DRIVEWAY PERMIT, AND STORMWATER PERMIT.
- A NPDES CONSTRUCTION GENERAL PERMIT AND STORMWATER POLLUTION PREVENTION PLAN IS REQUIRED PRIOR TO THE START OF ANY EARTH DISTURBING ACTIVITIES ON THE SITE.
- APPLICANT IS RESPONSIBLE TO PERFORM ALL SNOW AND ICE REMOVAL OPERATIONS AS WELL AS OTHER MAINTENANCE OPERATIONS AS REQUIRED PRIOR TO TOWN ACCEPTANCE.
- THE NRCS SOIL SURVEY OF THE SITE INDICATES THE PRESENCE OF HAVEN-URBAN LAND COMPLEX (HYDROLOGIC SOIL GROUP (HSG) A) AND PAXTON-URBAN LAND COMPLEX (HSG C).
- NO EXISTING VARIANCES OR SPECIAL PERMITS WERE ENCOUNTERED DURING RESEARCH OF THE EXISTING PARCELS.

# DEFINITIVE SUBDIVISION PLANS FOR 135, 139 & 149R HOWARD STREET (MAP 10 / LOTS 75, 76 & 77) READING, MASSACHUSETTS 01867

**LOCUS MAP**  
(SCALE: 1:1,000)



**LEGEND**

|   |           |
|---|-----------|
| PROPERTY LINE                                       | —         |
| ABUTTERS PROPERTY LINE                              | —         |
| EXISTING EDGE OF PAVEMENT                           | —         |
| EXISTING LIMIT OF BORDERING VEGETATED WETLAND (BWV) | —         |
| EXISTING WETLAND                                    | —         |
| EXISTING 25 FT BUFFER ZONE TO BWV                   | —         |
| EXISTING 35 FT BUFFER ZONE TO BWV                   | —         |
| EXISTING 100 FT BUFFER ZONE TO BWV                  | —         |
| EXISTING STRUCTURE                                  | —         |
| EXISTING CONTOUR                                    | —         |
| EXISTING WATER                                      | —         |
| EXISTING HYDRANT                                    | —         |
| EXISTING GATE VALVE                                 | —         |
| EXISTING SEWER                                      | —         |
| EXISTING DRAIN                                      | —         |
| EXISTING TREE LINE                                  | —         |
| EXISTING STONE WALL                                 | —         |
| TEST PIT  | —         |
| EXISTING IRON PIN                                   | —         |
| EXISTING MONUMENT                                   | —         |
| BUILDING SETBACK                                    | —         |
| CENTERLINE  | 0+50 1+00 |
| PROPOSED STRUCTURE                                  | —         |
| PROPOSED CURB                                       | —         |
| PROPOSED PAVEMENT                                   | —         |
| PROPOSED TREE LINE                                  | —         |
| PROPOSED CONTOUR                                    | —         |
| PROPOSED SPOT GRADE                                 | —         |
| PROPOSED DRAIN                                      | —         |
| PROPOSED ROCK RIP-RAP                               | —         |
| PROPOSED SILT FENCE                                 | —         |
| PROPOSED WATER                                      | —         |
| PROPOSED GATE VALVE/REDUCER & HYDRANT               | —         |
| PROPOSED GAS  | —         |
| PROPOSED SEWER                                      | —         |
| PROPOSED SEWER F.M.                                 | —         |
| PROPOSED SEWER MANHOLE                              | —         |
| PROPOSED ELECTRIC/TELEPHONE/CABLE                   | —         |
| PROPOSED MONUMENT                                   | —         |
| PROPOSED IRON PIN                                   | —         |
| PROPOSED EASEMENT                                   | —         |
| PROPOSED SIGN                                       | —         |
| PROPOSED LIMIT OF WORK                              | —         |
| PROPOSED RETAINING WALL                             | —         |
| PROPOSED LANDSCAPE AREA                             | —         |

**LIST OF ABUTTERS**

- |  |  |
|--|--|
| 42 WESCROFT ROAD<br>JUDITH E BASTERI<br>10-243<br>42 WESCROFT ROAD<br>READING, MA 01867                              | 144 HOWARD STREET<br>RICHARD A & PAULINE D<br>MASTRONARDI<br>10-112<br>144 HOWARD STREET<br>READING, MA 01867          |
| 78 WESCROFT ROAD<br>DANIEL W & GALE A CAHOON<br>10-249<br>78 WESCROFT ROAD<br>READING, MA 01867                      | 125 HOWARD STREET<br>ALBERT L & PATRICIA A<br>STEWART<br>10-79<br>125 HOWARD STREET<br>READING, MA 01867               |
| 62 WESCROFT ROAD<br>CHARLES M & JUDITH CHENEY<br>CASTELLUCCIO<br>10-245<br>62 WESCROFT ROAD<br>READING, MA 01867     | 21 MILTON ROAD<br>ALEX S & BARBARA J WILSON<br>10-98<br>21 MILTON ROAD<br>READING, MA 01867                            |
| 126 HOWARD STREET<br>GARY M & CHRISTINE M<br>COLLYMORE<br>10-117<br>126 HOWARD STREET<br>READING, MA 01867           | 140 HOWARD STREET<br>HENRY D & ANN C TOOMEY<br>10-113<br>140 HOWARD STREET<br>READING, MA 01867                        |
| 25 MILTON ROAD<br>FRANCIS J & JUDITH A DUNN<br>10-96<br>25 MILTON ROAD<br>READING, MA 01867                          | 127 HOWARD STREET<br>STEPHEN N & LEAH HARRINGTON<br>10-78<br>127 HOWARD STREET<br>READING, MA 01867                    |
| 132 HOWARD STREET<br>WILLIAM J & LEIGH S FULLER<br>10-115<br>132 HOWARD STREET<br>READING, MA 01867                  | 38 WESCROFT ROAD<br>SEAN M & DENISE M EWALD<br>10-242<br>38 WESCROFT ROAD<br>READING, MA 01867                         |
| 70 WESCROFT ROAD<br>JANICE L HART, TRUSTEE<br>JANICE L HART TRUST<br>10-247<br>70 WESCROFT ROAD<br>READING, MA 01867 | 129 HOWARD STREET<br>ROUZBEH SHANJANI &<br>NASSERHELALI NADEREH<br>10-167<br>129 HOWARD STREET<br>READING, MA 01867    |
| 74 WESCROFT ROAD<br>JUDSON G GRAHAM JR<br>STEPHANIE N GRAHAM<br>10-248<br>74 WESCROFT ROAD<br>READING, MA 01867      | 11 MILTON ROAD<br>WILLIAM & JESSICA LYNCH<br>10-93<br>11 MILTON ROAD<br>READING, MA 01867                              |
| 56 WESCROFT ROAD<br>JOHN R & MARIE A KLEPONIS<br>10-244<br>56 WESCROFT ROAD<br>READING, MA 01867                     | 128 HOWARD STREET<br>CHRISTOPHER M & HEATHER M<br>WICKEN<br>10-116<br>128 HOWARD STREET<br>READING, MA 01867           |
| 82 WESCROFT ROAD<br>ROBERT H & JO-ANN M<br>GREGOROWICZ<br>10-250<br>82 WESCROFT ROAD<br>READING, MA 01867            | 151 HOWARD STREET<br>KAREN ANNE LITTLE<br>10-73<br>151 HOWARD STREET<br>READING, MA 01867                              |
| 136 HOWARD STREET<br>ANNE M GROGAN<br>10-114<br>136 HOWARD STREET<br>READING, MA 01867                               | 66 WESCROFT ROAD<br>DIANA PIASECKI<br>10-246<br>66 WESCROFT ROAD<br>READING, MA 01867                                  |
| 148 HOWARD STREET<br>MARC A & GIULIANA N RIZZO<br>10-111<br>148 HOWARD STREET<br>READING, MA 01867                   | 17 MILTON ROAD<br>JOHN F LYNCH ET AL TRUSTEES<br>MJ LYNCH FAMILY TRUST<br>10-94<br>17 MILTON ROAD<br>READING, MA 01867 |
| 7 MILTON ROAD<br>LYNN E FREEDMAN<br>10-92<br>7 MILTON ROAD<br>READING, MA 01867                                      |  |

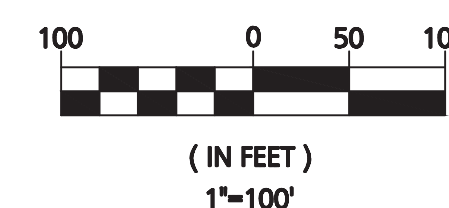

**PLAN INDEX:**

| TITLE                                    | DATE ISSUED |
|--|-------------|
| C-1 COVER SHEET                          | 01/27/20    |
| C-2 EXISTING CONDITIONS PLAN             | 01/15/20    |
| C-2A PLAN OF LAND                        | 11/11/19    |
| C-3 SUBDIVISION PLAN                     | 01/15/20    |
| C-4 ROADWAY PLAN & CENTERLINE PROFILE    | 01/27/20    |
| C-5 GRADING, DRAINAGE & LANDSCAPING PLAN | 01/27/20    |
| C-6 EROSION CONTROL PLAN                 | 01/27/20    |
| C-7 TREE REMOVAL PLAN                    | 01/27/20    |
| D-1 CONSTRUCTION DETAILS                 | 01/27/20    |
| D-2 CONSTRUCTION DETAILS                 | 01/27/20    |
| D-3 CONSTRUCTION DETAILS                 | 01/27/20    |
| D-4 CONSTRUCTION DETAILS                 | 01/27/20    |

FOR REGISTRY USE ONLY  
THIS PLAN WAS PREPARED IN ACCORDANCE WITH THE RULES AND REGULATIONS FOR RECORDING ADOPTED BY THE REGISTERS OF DEEDS IN 1978 AND AMENDED JANUARY 12, 1988.

ENGINEER: \_\_\_\_\_ DATE: \_\_\_\_\_  
APPROVED BY THE TOWN OF READING  
COMMUNITY PLANNING AND  
DEVELOPMENT COMMISSION

CERTIFICATE OF ACTION  
DATE OF ENDORSEMENT

|           |                           |
|-----------|---------------------------|
| 01/27/20  | REVISIONS PER TOWN REVIEW |
| 11/08/19  | REVISIONS PER TOWN REVIEW |
| DATE      | DESCRIPTION               |
| REVISIONS |                           |

OWNER / APPLICANT:  
**INFRASTRUCTURE HOLDINGS, LLC**  
122 BOSTON ROAD  
BILLERICA, MA 01862

PROJECT:  
**135, 139 & 149R HOWARD STREET**  
READING, MA 01867

DATE ISSUED: DECEMBER 21, 2018

PROJECT #: 18-10120

PREPARED BY: WILLIAM HALL, P.E.

01/27/20

PROFESSIONAL ENGINEER FOR CIVIL DESIGN  
CONSULTANTS, INC.

**CIVIL DESIGN Consultants, Inc.**  
SURVEY • DESIGN • PERMITTING • CONSTRUCTION ADMINISTRATION

30 River Street Methuen, MA 01844 Tel: (978) 416-0920 Fax: (978) 416-7865

DRAWING TITLE:

COVER SHEET

DRAWING #:

C-1

ISSUED FOR REVIEW: JANUARY 27, 2020

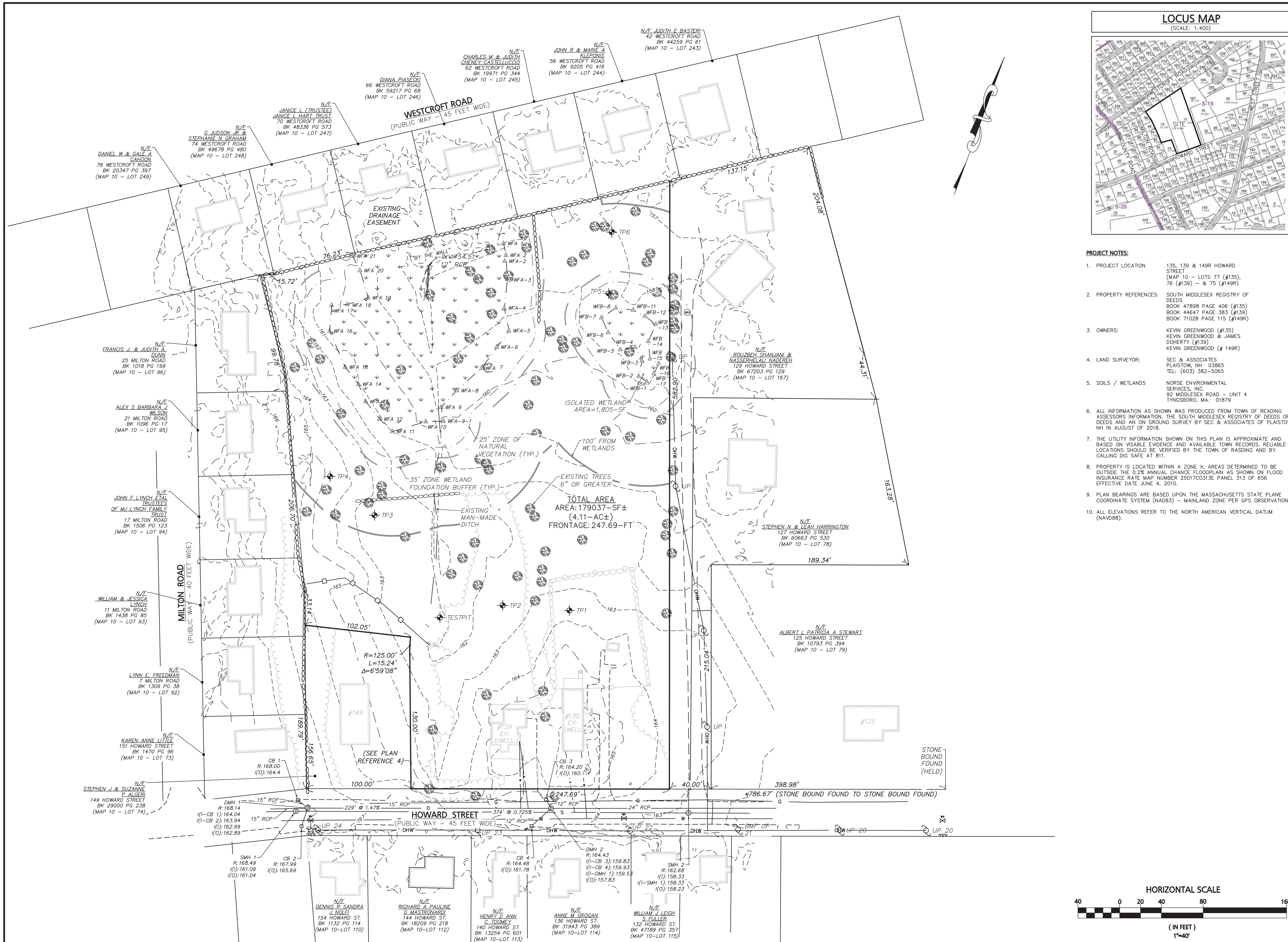

FOR REGISTRY USE ONLY  
 THIS PLAN WAS PREPARED IN ACCORDANCE WITH THE RULES AND REGULATIONS FOR RECORDING ADOPTED BY THE REGISTERS OF DEEDS IN 1978 AND AMENDED JANUARY 12, 1988.

*Warren A. Wagner*  
 01-21-2020  
 SURVEYOR DATE

- PROJECT NOTES:**
- PROJECT LOCATION: 135, 139 & 149R HOWARD STREET (MAP 10 - LOTS 77 (#135), 76 (#139) - & 75 (#149R))
  - PROPERTY REFERENCES: SOUTH MIDDLESEX REGISTRY OF DEEDS BOOK 47898 PAGE 406 (#135) BOOK 44647 PAGE 383 (#139) BOOK 71028 PAGE 115 (#149R)
  - OWNERS: KEVIN GREENWOOD (#135) KEVIN GREENWOOD & JAMES DOHERTY (#139) KEVIN GREENWOOD (#149R)
  - LAND SURVEYOR: SEC & ASSOCIATES PLAISTOW, NH 03865 TEL: (603) 382-5065
  - SOILS / WETLANDS: NORSE ENVIRONMENTAL SERVICES, INC. 92 MIDDLESEX ROAD - UNIT 4 TYNGSBORO, MA. 01879
  - ALL INFORMATION AS SHOWN WAS PRODUCED FROM TOWN OF READING ASSESSORS INFORMATION, THE SOUTH MIDDLESEX REGISTRY OF DEEDS OF DEEDS AND AN ON GROUND SURVEY BY SEC & ASSOCIATES OF PLAISTOW, NH IN AUGUST OF 2018.
  - THE UTILITY INFORMATION SHOWN ON THIS PLAN IS APPROXIMATE AND BASED ON VISIBLE EVIDENCE AND AVAILABLE TOWN RECORDS. RELIABLE LOCATIONS SHOULD BE VERIFIED BY THE TOWN OF READING AND BY CALLING DIG SAFE AT 811.
  - PROPERTY IS LOCATED WITHIN A ZONE X, AREAS DETERMINED TO BE OUTSIDE THE 0.2% ANNUAL CHANCE FLOODPLAIN AS SHOWN ON FLOOD INSURANCE RATE MAP NUMBER 25017C0313E PANEL 313 OF 656 EFFECTIVE DATE JUNE 4, 2010.
  - PLAN BEARINGS ARE BASED UPON THE MASSACHUSETTS STATE PLANE COORDINATE SYSTEM (NAD83) - MAINLAND ZONE PER GPS OBSERVATIONS.
  - ALL ELEVATIONS REFER TO THE NORTH AMERICAN VERTICAL DATUM (NAVD88).

| DATE     | DESCRIPTION                    |
|----------|--------------------------------|
| 01/15/20 | IN ACCORDANCE WITH TOWN REVIEW |
| 11/11/19 | IN ACCORDANCE WITH TOWN REVIEW |
| 10/23/19 | REVISE WETLAND DELINEATION     |

APPLICANT:  
**INFRASTRUCTURE HOLDINGS, LLC**  
 122 BOSTON ROAD  
 BILLERICA, MA 01862

PROJECT:  
**135, 139 & 149R, HOWARD STREET**  
 READING, MA 01867

|              |                   |
|--------------|-------------------|
| DATE ISSUED: | DECEMBER 21, 2018 |
| PROJECT #:   | 18-10020          |
| PREPARED BY: | WARREN A. WAGNER  |



PROFESSIONAL LAND SURVEYOR FOR CIVIL DESIGN CONSULTANTS, INC.

**CIVIL DESIGN Consultants, Inc.**  
 SURVEY - DESIGN - PERMITTING - CONSTRUCTION ADMINISTRATION

30 River Street Methuen, MA 01844 Tel: (978) 416-0920 Fax: (978) 416-7865

DRAWING TITLE:  
**EXISTING CONDITIONS PLAN**

DRAWING #:

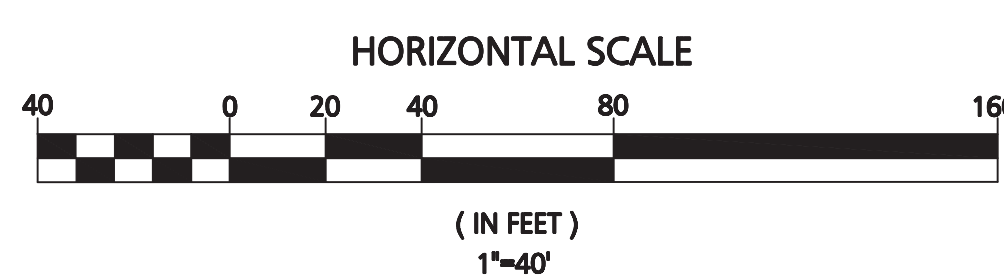

C-2

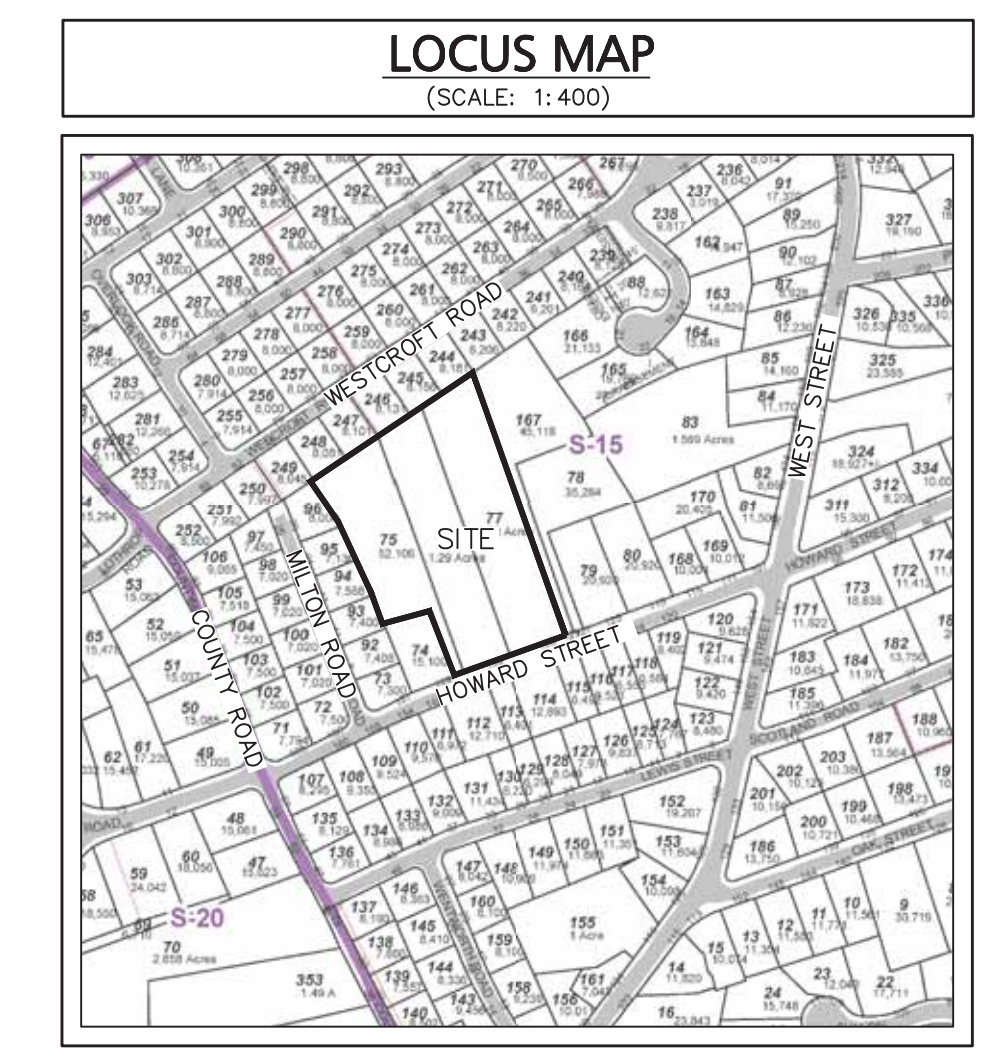

- PROJECT NOTES:**
- PROJECT LOCATION: 135, 139 & 149R HOWARD STREET (MAP 10 - LOTS 77 (#135), 76 (#139) - & 75 (#149R))
  - PROPERTY REFERENCES: SOUTH MIDDLESEX REGISTRY OF DEEDS BOOK 47898 PAGE 406 (#135) BOOK 44647 PAGE 383 (#139) BOOK 71028 PAGE 115 (#149R)
  - OWNERS: KEVIN GREENWOOD (#135) KEVIN GREENWOOD & JAMES DOHERTY (#139) KEVIN GREENWOOD (#149R)
  - LAND SURVEYOR: SEC & ASSOCIATES PLAISTOW, NH 03865 TEL: (603) 382-5065
  - SOILS / WETLANDS: NORSE ENVIRONMENTAL SERVICES, INC. 92 MIDDLESEX ROAD - UNIT 4 TYNGSBORO, MA. 01879
  - ALL INFORMATION AS SHOWN WAS PRODUCED FROM TOWN OF READING ASSESSORS INFORMATION, THE SOUTH MIDDLESEX REGISTRY OF DEEDS AND AN ON GROUND SURVEY BY SEC & ASSOCIATES OF PLAISTOW, NH IN AUGUST OF 2018.
  - PROPERTY IS LOCATED WITHIN A ZONE X, AREAS DETERMINED TO BE OUTSIDE THE 0.2% ANNUAL CHANCE FLOODPLAIN AS SHOWN ON FLOOD INSURANCE RATE MAP NUMBER 2501700313E PANEL 313 OF 656 EFFECTIVE DATE JUNE 4, 2010.
  - PLAN BEARINGS ARE BASED UPON THE MASSACHUSETTS STATE PLANE COORDINATE SYSTEM (NAD83) - MAINLAND ZONE PER GPS OBSERVATIONS.

- REFERENCE PLANS:**
- SEE LAND COURT PLAN OF LAND IN READING PREPARED BY DANA F. PERKINS DATED MARCH 1941 RECORDED IN THE SOUTH MIDDLESEX REGISTRY OF DEEDS AS LC PLAN NO. 16432F.
  - SEE PLAN OF LOTS BELONGING TO GEORGE H. & JUNE Y. KILMARX PREPARED BY H. KINGMAN ABBOTT DATED SEPTEMBER 6, 1973 AND RECORDED IN THE SOUTH MIDDLESEX REGISTRY OF DEEDS AS PLAN NUMBER 296 OF 1974.
  - SEE PLAN OF WESTCROFT PARK PREPARED BY DANA F. PERKINS DATED MAY 1940 AND RECORDED IN THE SOUTH MIDDLESEX REGISTRY OF DEEDS AS PLAN NUMBER 581 OF 1940.
  - SEE PLAN OF LAND PREPARED FORMICHAEL & MAUREN DELEO PREPARED BY MARCHIONDA & ASSOCIATES, INC. DATED SEPTEMBER 28, 1994 AND RECORDED IN THE SOUTH MIDDLESEX REGISTRY OF DEEDS AS PLAN NUMBER 1202 OF 1994.
  - SEE PLAN - HOWARD STREET EXTENSION PREPARED BY DAVIS & ABBOTT DATED FEBRUARY 1929 AVAILABLE AT READING TOWN HALL ENGINEERS OFFICE.
  - SEE UNRECORDED PLAN OF LAND PREPARED BY DANA PERKINS DATED MARCH 17, 1937 AVAILABLE AT READING TOWN HALL ENGINEERS OFFICE.

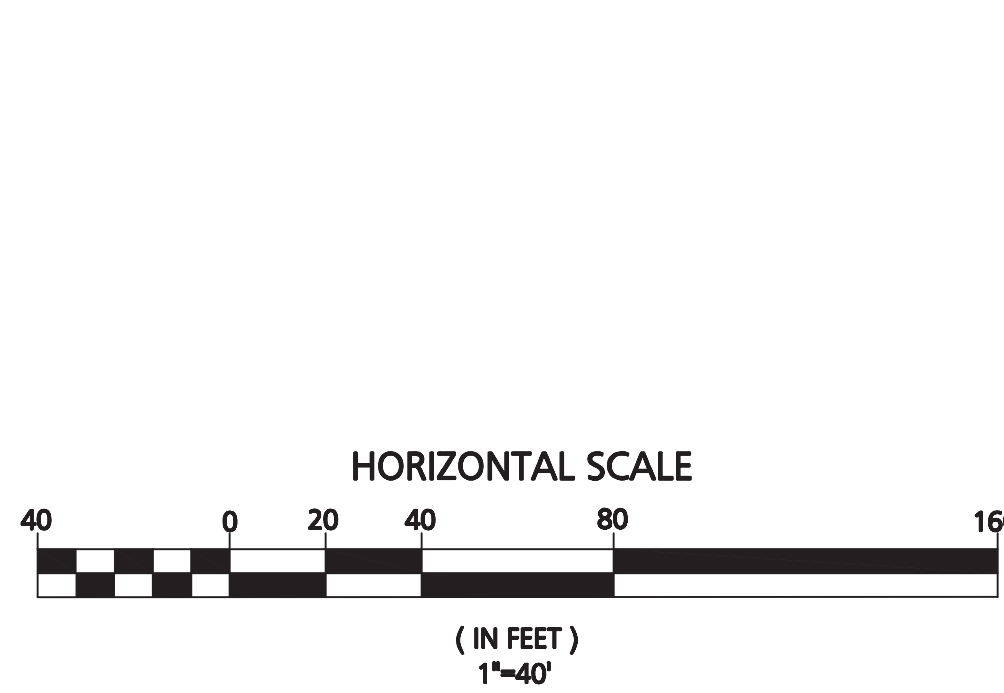

FOR REGISTRY USE ONLY  
 THIS PLAN WAS PREPARED IN ACCORDANCE WITH THE RULES AND REGULATIONS FOR RECORDING ADOPTED BY THE REGISTERS OF DEEDS IN 1978 AND AMENDED JANUARY 12, 1988.

*Warren A. Wagner*  
 SURVEYOR DATE 01-21-2020

| DATE     | DESCRIPTION                    |
|----------|--------------------------------|
| 11/11/19 | IN ACCORDANCE WITH TOWN REVIEW |
|          |                                |
|          |                                |
|          |                                |
|          |                                |
|          |                                |
|          |                                |
|          |                                |
|          |                                |

APPLICANT:  
**INFRASTRUCTURE HOLDINGS, LLC**  
 122 BOSTON ROAD  
 BILLERICA, MA 01862

PROJECT:  
**135, 139 & 149R, HOWARD STREET**  
 READING, MA 01867

DATE ISSUED: DECEMBER 21, 2018

PROJECT #: 18-10020

PREPARED BY: WARREN A. WAGNER

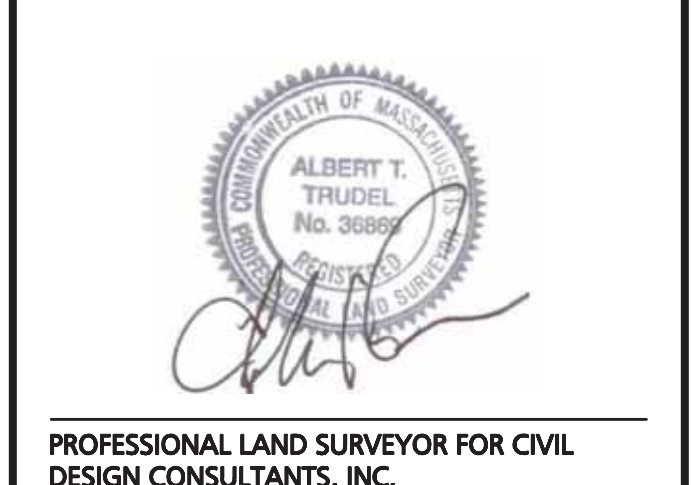

**CIVIL DESIGN Consultants, Inc.**  
 SURVEY - DESIGN - PERMITTING - CONSTRUCTION ADMINISTRATION

30 River Street  
 Methuen, MA 01844 Tel: (978) 416-0920  
 Fax: (978) 416-7865

DRAWING TITLE:  
**PLAN OF LAND**

DRAWING #:  
**C-2A**

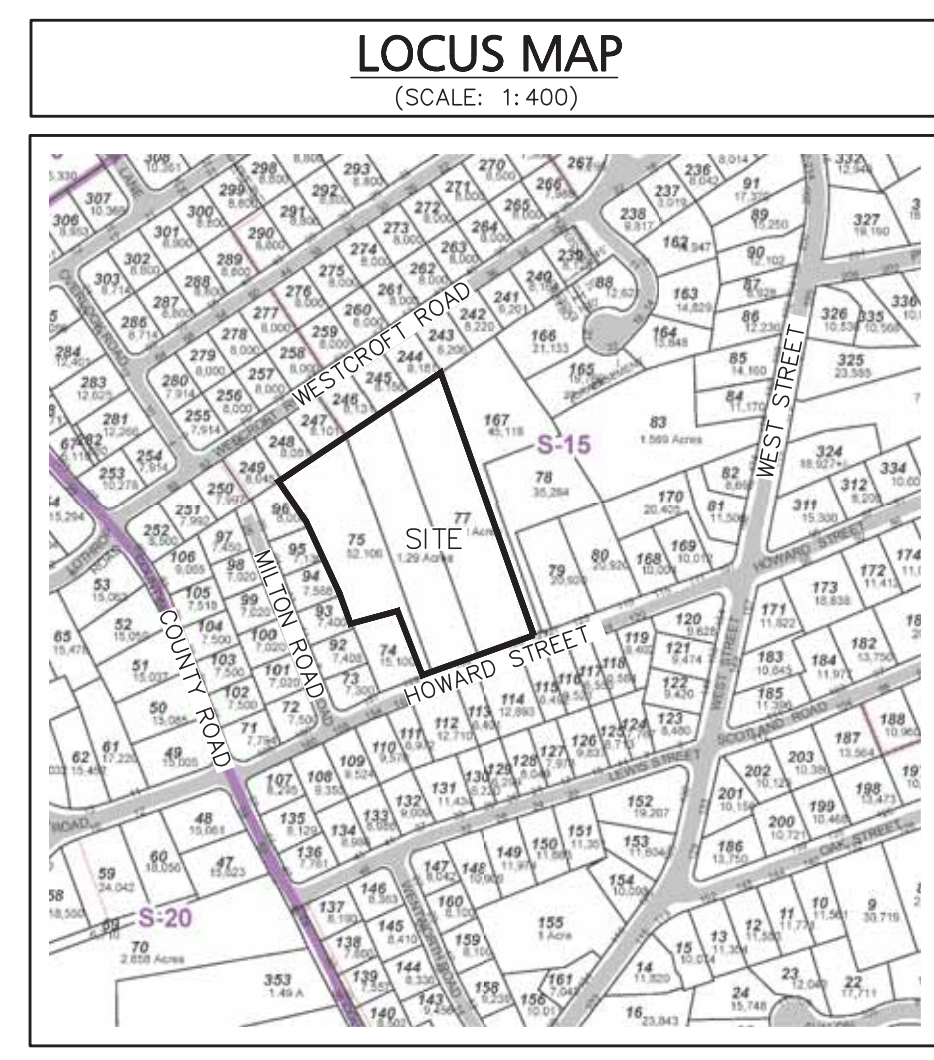

**LAND USE TABLES**

LOCATION: 135, 139 149R HOWARD STREET  
READING, MA 01876

ZONE: RESIDENCE DISTRICT - S-15 DISTRICT  
USE: SINGLE FAMILY RESIDENTIAL

|                        | REQUIRED  |
|------------------------|-----------|
| MINIMUM LOT AREA       | 15,000-SF |
| MINIMUM LOT FRONTAGE   | 100- FEET |
| MINIMUM FRONT SETBACK  | 20- FEET  |
| MINIMUM SIDE SETBACK   | 15- FEET  |
| MINIMUM REAR SETBACK   | 25%       |
| MAX. BUILDING COVERAGE | 15%       |

- PROJECT NOTES:**
- PROJECT LOCATION: 135, 139 & 149R HOWARD STREET (MAP 10 - LOTS 77 (#135), 76 (#139) - & 75 (#149R))
  - PROPERTY REFERENCES: SOUTH MIDDLESEX REGISTRY OF DEEDS BOOK 47898 PAGE 406 (#135) BOOK 44647 PAGE 383 (#139) BOOK 71026 PAGE 115 (#149R)
  - OWNERS: KEVIN GREENWOOD (#135) KEVIN GREENWOOD & JAMES DOHERTY (#139) KEVIN GREENWOOD (#149R)
  - LAND SURVEYOR: SEC & ASSOCIATES PLAISTOW, NH 03865 TEL: (603) 382-5065
  - SOILS / WETLANDS: NORSE ENVIRONMENTAL SERVICES, INC. 92 MIDDLESEX ROAD - UNIT 4 TYNGSBORO, MA. 01879

FOR REGISTRY USE ONLY  
THIS PLAN WAS PREPARED IN ACCORDANCE WITH THE RULES AND REGULATIONS FOR RECORDING ADOPTED BY THE REGISTERS OF DEEDS IN 1978 AND AMENDED JANUARY 12, 1988.

*Warren A. Wagner*  
01-21-2020  
SURVEYOR DATE

| REVISIONS | DATE | DESCRIPTION                    |
|-----------|------|--------------------------------|
| 01/15/20  |      | IN ACCORDANCE WITH TOWN REVIEW |
| 11/11/19  |      | IN ACCORDANCE WITH TOWN REVIEW |

**APPLICANT:**  
**INFRASTRUCTURE HOLDINGS, LLC**  
122 BOSTON ROAD  
BILLERICA, MA 01862

**PROJECT:**  
**135, 139 & 149R, HOWARD STREET**  
READING, MA 01867

**DATE ISSUED:** DECEMBER 21, 2018

**PROJECT #:** 18-10020

**PREPARED BY:** WARREN A. WAGNER

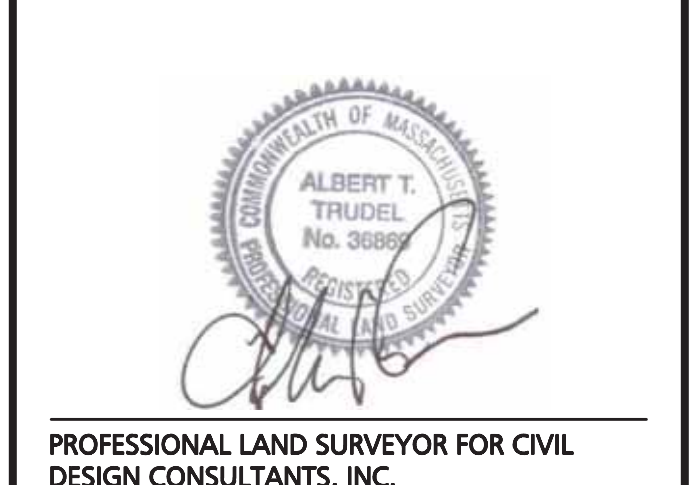

PROFESSIONAL LAND SURVEYOR FOR CIVIL DESIGN CONSULTANTS, INC.

**CIVIL DESIGN Consultants, Inc.**  
SURVEY - DESIGN - PERMITTING - CONSTRUCTION ADMINISTRATION

30 River Street  
Methuen, MA 01844  
Tel: (978) 416-0920  
Fax: (978) 416-7865

**DRAWING TITLE:**  
SUBDIVISION PLAN

**DRAWING #:**  
C-3

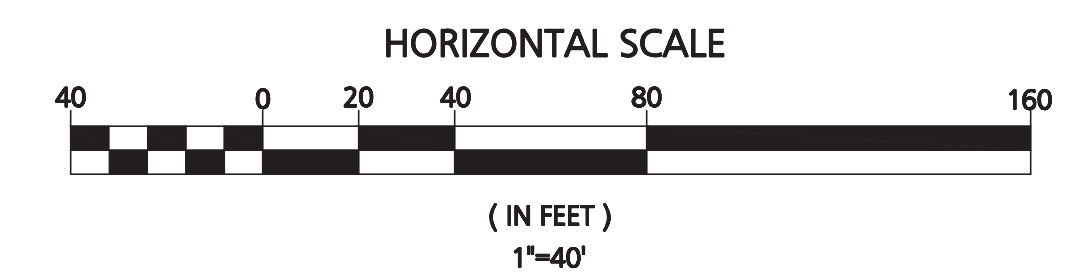



**NOTES:**

- SEE SHEET C-1 FOR COMPLETE PROJECT NOTES.
- PLAN BEARINGS ARE BASED UPON THE MASSACHUSETTS STATE PLANE COORDINATE SYSTEM (NAD83) - MAINLAND ZONE PER GPS OBSERVATIONS.
- ELEVATIONS ARE BASED UPON THE NORTH AMERICAN VERTICAL DATUM (NAVD83) PER GPS OBSERVATIONS.
- SOILS ON SITE CONSIST OF HAVEN-URBAN LAND COMPLEX AND PAXTON-URBAN LAND COMPLEX PER NRCS MAPS. SOIL TEST PITS INDICATED LOAMY SAND AND GRAVEL SOILS. SEE SUBMITTED WATERSHED MAPS AND SOIL LOGS FOR FURTHER DETAIL.

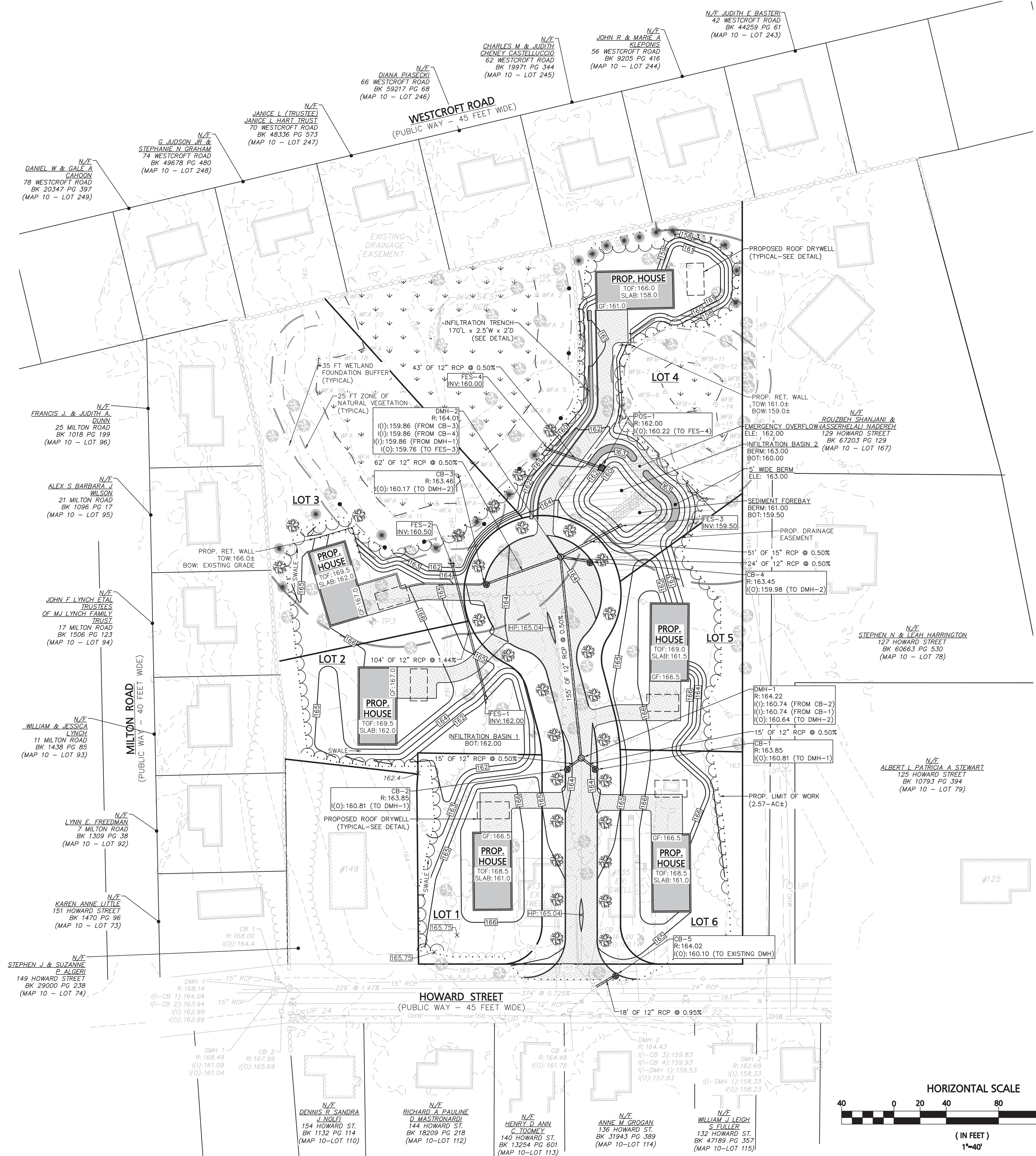
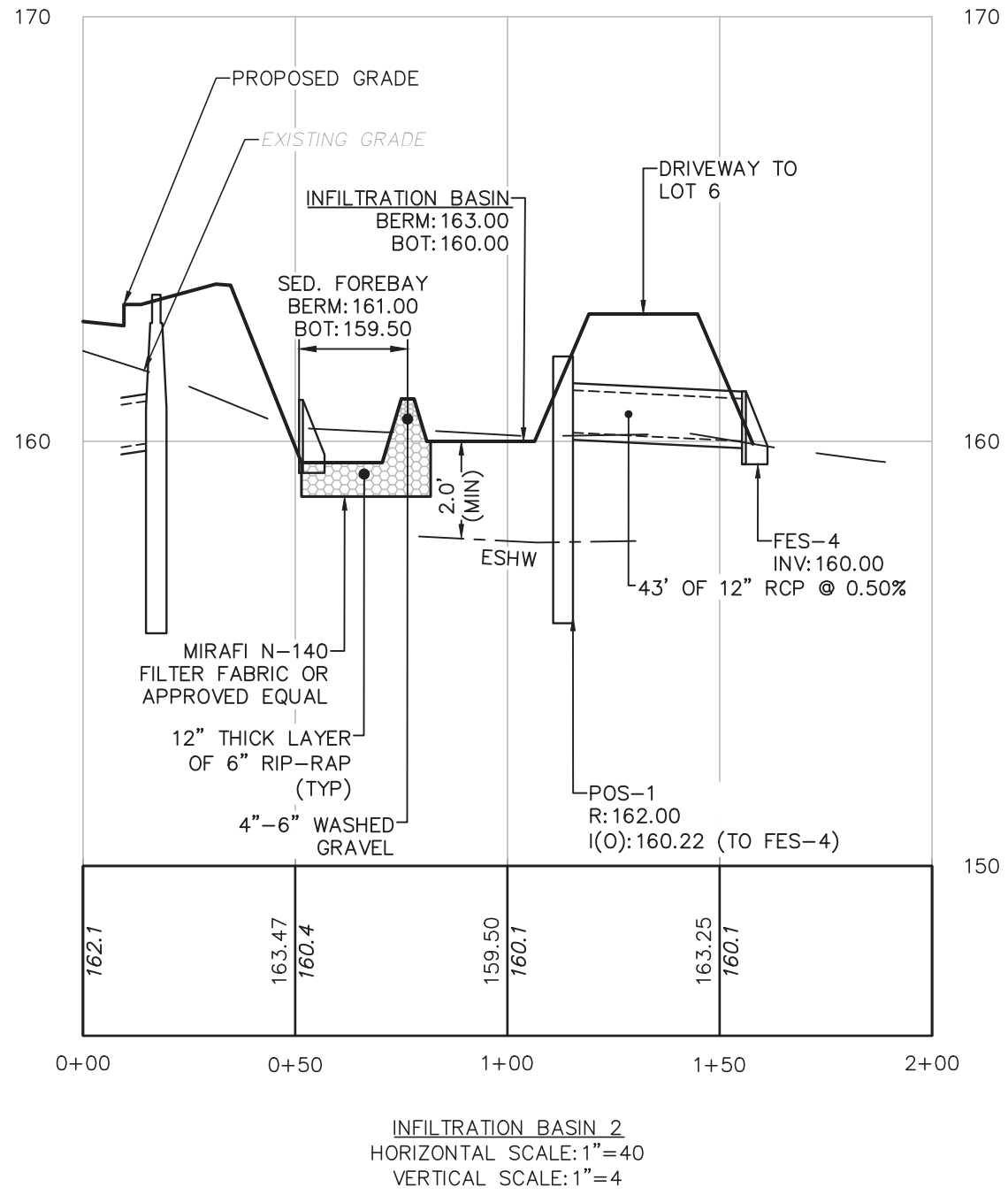

FOR REGISTRY USE ONLY  
 THIS PLAN WAS PREPARED IN ACCORDANCE WITH THE RULES AND REGULATIONS FOR RECORDING ADOPTED BY THE REGISTERS OF DEEDS IN 1978 AND AMENDED JANUARY 12, 1988.

|   |      |
|---|------|
| ENGINEER  | DATE |
| APPROVED BY THE TOWN OF READING<br>COMMUNITY PLANNING AND<br>DEVELOPMENT COMMISSION |      |
|   |      |
|   |      |
|   |      |
|   |      |
| CERTIFICATE OF ACTION   |      |
| DATE OF ENDORSEMENT   |      |

|           |                           |
|-----------|---------------------------|
| 01/27/20  | REVISIONS PER TOWN REVIEW |
| 11/08/19  | REVISIONS PER TOWN REVIEW |
| DATE      | DESCRIPTION               |
| REVISIONS |                           |

OWNER / APPLICANT:  
**INFRASTRUCTURE HOLDINGS, LLC**  
 122 BOSTON ROAD  
 BILLERICA, MA 01862

PROJECT:  
**135, 139 & 149R HOWARD STREET**  
 READING, MA 01867

|              |                    |
|--------------|--------------------|
| DATE ISSUED: | DECEMBER 21, 2018  |
| PROJECT #:   | 18-10120           |
| PREPARED BY: | WILLIAM HALL, P.E. |

01/27/20

PROFESSIONAL ENGINEER FOR CIVIL DESIGN CONSULTANTS, INC.



30 River Street Methuen, MA 01844 Tel: (978) 416-0920 Fax: (978) 416-7865

DRAWING TITLE:  
**GRADING, DRAINAGE & LANDSCAPING**

DRAWING #:  
**C-5**

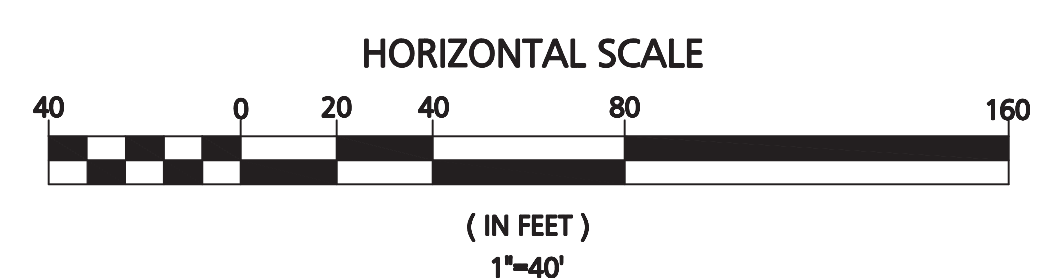

- NOTES:
- SEE SHEET C-1 FOR COMPLETE PROJECT NOTES.
  - PLAN BEARINGS ARE BASED UPON THE MASSACHUSETTS STATE PLANE COORDINATE SYSTEM (NAD83) - MAINLAND ZONE PER GPS OBSERVATIONS.
  - ELEVATIONS ARE BASED UPON THE NORTH AMERICAN VERTICAL DATUM (NAVD88) PER GPS OBSERVATIONS.

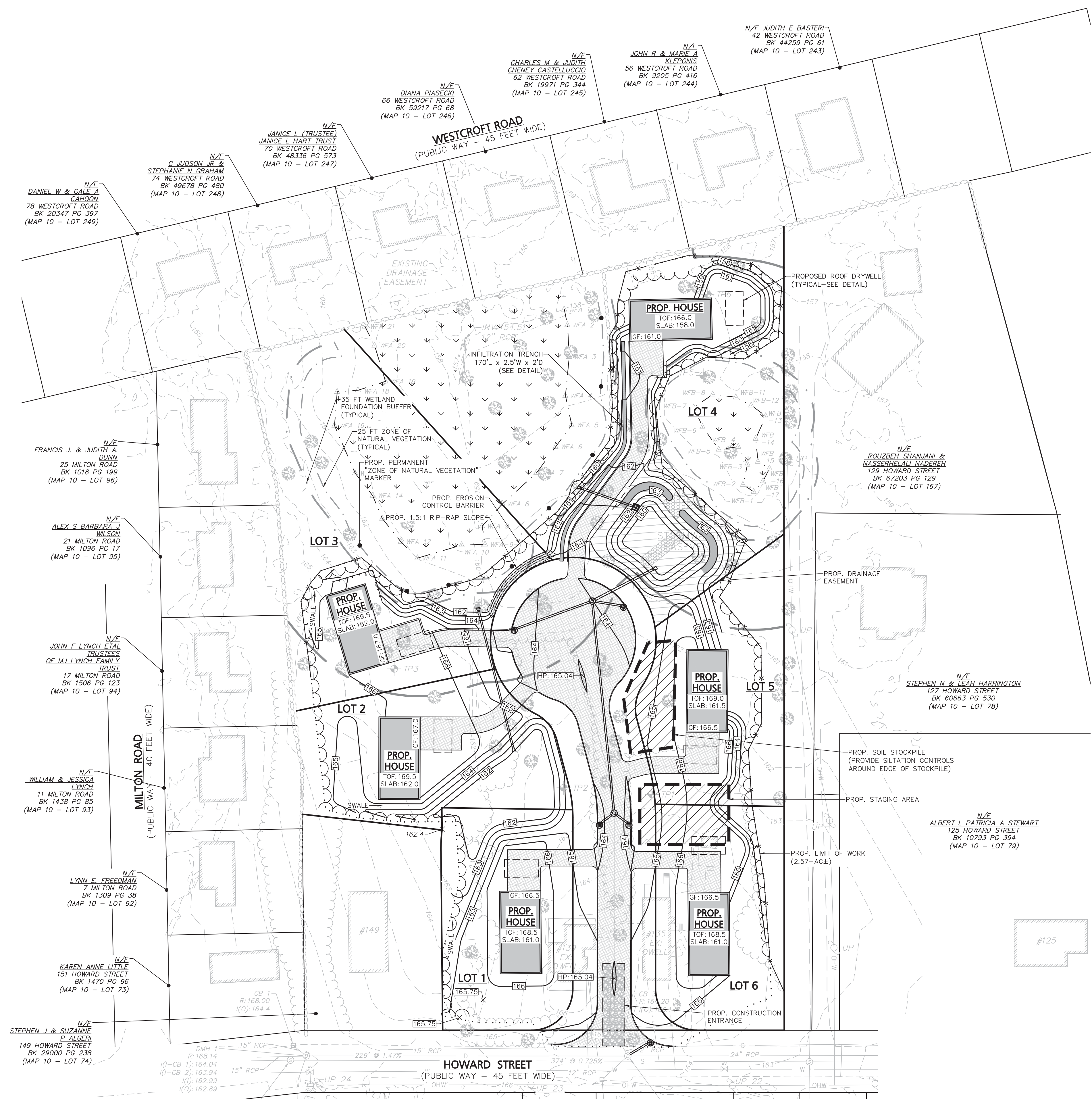

FOR REGISTRY USE ONLY  
 THIS PLAN WAS PREPARED IN ACCORDANCE WITH THE RULES AND REGULATIONS FOR RECORDING ADOPTED BY THE REGISTERS OF DEEDS IN 1978 AND AMENDED JANUARY 12, 1988.

|   |       |
|---|-------|
| ENGINEER  | DATE  |
| APPROVED BY THE TOWN OF READING<br>COMMUNITY PLANNING AND<br>DEVELOPMENT COMMISSION |       |
| _____   | _____ |
| _____   | _____ |
| _____   | _____ |
| CERTIFICATE OF ACTION   |       |
| DATE OF ENDORSEMENT   |       |

|           |                           |
|-----------|---------------------------|
| 01/27/20  | REVISIONS PER TOWN REVIEW |
| 11/08/19  | REVISIONS PER TOWN REVIEW |
| DATE      | DESCRIPTION               |
| REVISIONS |                           |

OWNER / APPLICANT:  
**INFRASTRUCTURE HOLDINGS, LLC**  
 122 BOSTON ROAD  
 BILLERICA, MA 01862

PROJECT:  
**135, 139 & 149R HOWARD STREET**  
 READING, MA 01867

|              |                    |
|--------------|--------------------|
| DATE ISSUED: | DECEMBER 21, 2018  |
| PROJECT #:   | 18-10120           |
| PREPARED BY: | WILLIAM HALL, P.E. |

01/27/20

PROFESSIONAL ENGINEER FOR CIVIL DESIGN  
 CONSULTANTS, INC.

**CIVIL DESIGN**  
 Consultants, Inc.  
 SURVEY • DESIGN • PERMITTING • CONSTRUCTION ADMINISTRATION

30 River Street  
 Methuen, MA 01844  
 Tel: (978) 416-0920  
 Fax: (978) 416-7865

DRAWING TITLE:  
**EROSION CONTROL PLAN**

DRAWING #:

**C-6**

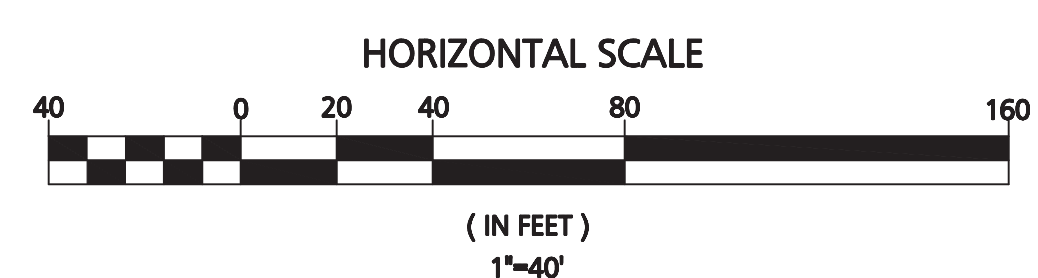

- NOTES:
- SEE SHEET C-1 FOR COMPLETE PROJECT NOTES.
  - PLAN BEARINGS ARE BASED UPON THE MASSACHUSETTS STATE PLANE COORDINATE SYSTEM (NAD83) - MAINLAND ZONE PER GPS OBSERVATIONS.
  - ELEVATIONS ARE BASED UPON THE NORTH AMERICAN VERTICAL DATUM (NAVD88) PER GPS OBSERVATIONS.
  - TREES REMOVED WITHIN THE BUFFER ZONE SHALL BE REPLACED AT A 1:1 RATIO. 24 TREES ARE PROPOSED TO BE REMOVED WITHIN THE 100-FT BUFFER ZONE AND 25 REPLACEMENT TREES ARE PROPOSED. REPLACEMENT TREE SIZE, SPECIES, AND FINAL LOCATION SHALL BE COORDINATED WITH THE TOWN OF READING TREE WARDEN AND CONSERVATION COMMISSION.
  - STREET TREES PLACED WITHIN THE PROPOSED RIGHT OF WAY ARE NOT TO BE COUNTED TOWARDS BUFFER ZONE REPLACEMENT TREES.



FOR REGISTRY USE ONLY  
 THIS PLAN WAS PREPARED IN ACCORDANCE WITH THE RULES AND REGULATIONS FOR RECORDING ADOPTED BY THE REGISTERS OF DEEDS IN 1978 AND AMENDED JANUARY 12, 1988.

|   |      |
|---|------|
| ENGINEER  | DATE |
| APPROVED BY THE TOWN OF READING<br>COMMUNITY PLANNING AND<br>DEVELOPMENT COMMISSION |      |
|   |      |
|   |      |
|   |      |
| CERTIFICATE OF ACTION   |      |
| DATE OF ENDORSEMENT   |      |

|           |                           |
|-----------|---------------------------|
| 01/27/20  | REVISIONS PER TOWN REVIEW |
| 11/08/19  | REVISIONS PER TOWN REVIEW |
| DATE      | DESCRIPTION               |
| REVISIONS |                           |

OWNER / APPLICANT:  
**INFRASTRUCTURE HOLDINGS, LLC**  
 122 BOSTON ROAD  
 BILLERICA, MA 01862

PROJECT:  
**135, 139 & 149R HOWARD STREET**  
 READING, MA 01867

|              |                    |
|--------------|--------------------|
| DATE ISSUED: | DECEMBER 21, 2018  |
| PROJECT #:   | 18-10120           |
| PREPARED BY: | WILLIAM HALL, P.E. |

01/27/20  
 PROFESSIONAL ENGINEER FOR CIVIL DESIGN  
 CONSULTANTS, INC.

**CIVIL DESIGN**  
 Consultants, Inc.  
 SURVEY • DESIGN • PERMITTING • CONSTRUCTION ADMINISTRATION

30 River Street  
 Methuen, MA 01844  
 Tel: (978) 416-0920  
 Fax: (978) 416-7865

DRAWING TITLE:  
**TREE REMOVAL PLAN**

DRAWING #:  
**C-7**

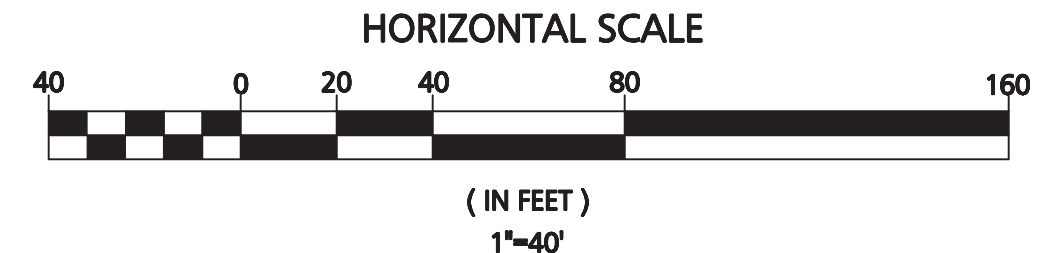



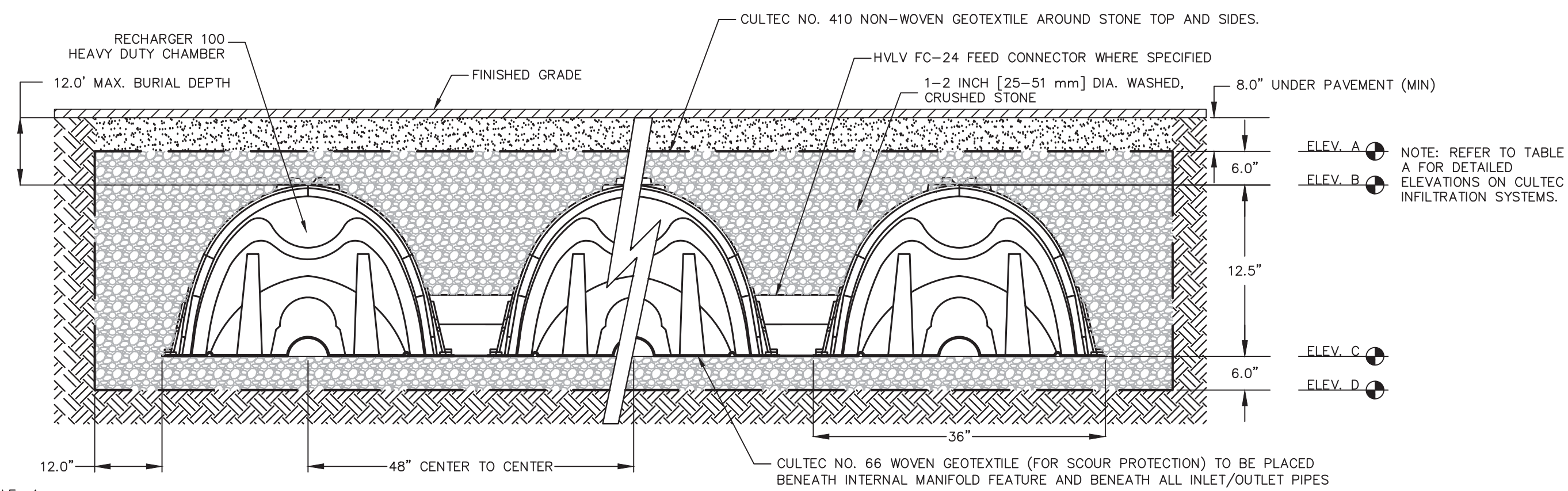
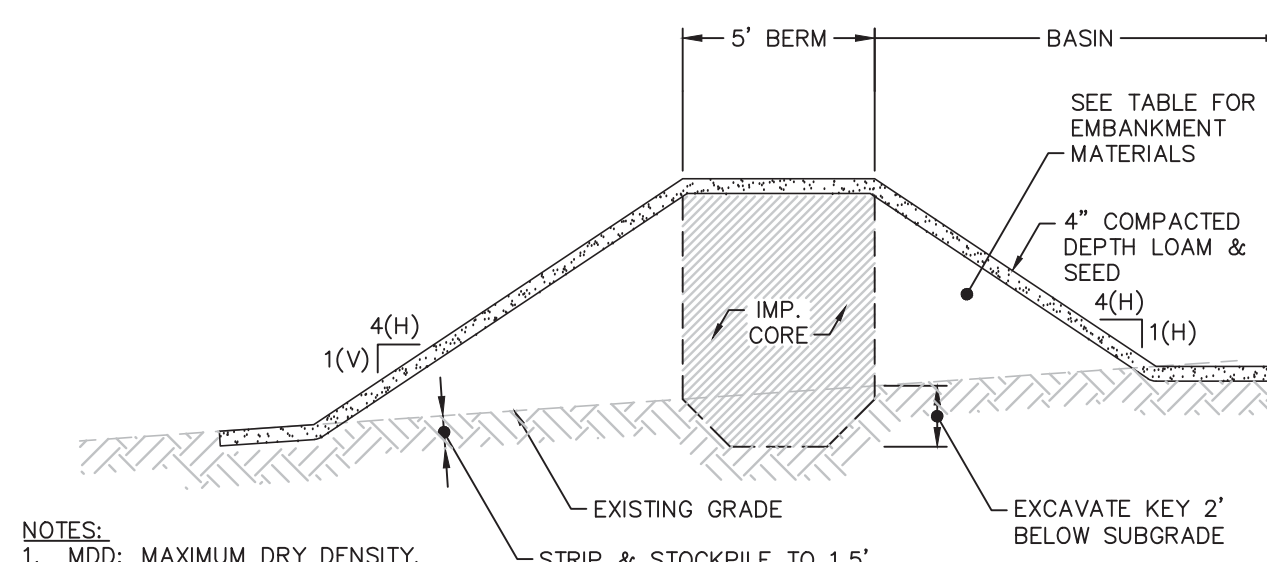

TABLE: A

|       | ELEV. A | ELEV. B | ELEV. C | ELEV. D |
|-------|---------|---------|---------|---------|
| LOT 1 | 164.54  | 164.04  | 163.00  | 162.50  |
| LOT 2 | 164.04  | 163.54  | 162.50  | 162.00  |
| LOT 3 | 164.04  | 163.54  | 162.50  | 162.00  |
| LOT 4 | 160.04  | 159.54  | 158.50  | 158.00  |
| LOT 5 | 164.54  | 164.04  | 163.00  | 162.50  |
| LOT 6 | 165.04  | 164.54  | 163.50  | 163.00  |

**CULTEC RECHARGER 100HD DETAIL**

NOT TO SCALE



- NOTES:
1. MDD: MAXIMUM DRY DENSITY.
  2. ACCEPTABLE TO ENGINEER.
  3. COMPACT TO TEST AVERAGE OF 92% NO TEST LESS THAN 90.

| LOCATION   | MATERIAL                                 | MAX. PARTICLE SIZE (IN) | LOOSE LIFT THICKNESS (IN) | COMPACTION REQUIREMENTS (% MDD) <sup>1</sup> |
|------------|--|-------------------------|---------------------------|--|
| KEY        | NATIVE SOIL <sup>2</sup>                 | 6                       | 12 (MAX)                  | 92% <sup>3</sup>                             |
| EMBANKMENT | NATIVE SOIL <sup>2</sup>                 | 6                       | 12 (MAX)                  | 92% <sup>3</sup>                             |
| LOAM COVER | NATIVE TOPSOIL                           | 1                       | 8 (MIN)                   | 80%  |
| IMP. CORE  | SOIL W/ AT LEAST 30% CLAY & SILT CONTENT | 3                       | 12 (MAX)                  | 92% <sup>3</sup>                             |

**PROPOSED POND EMBANKMENT DETAIL**

NOT TO SCALE

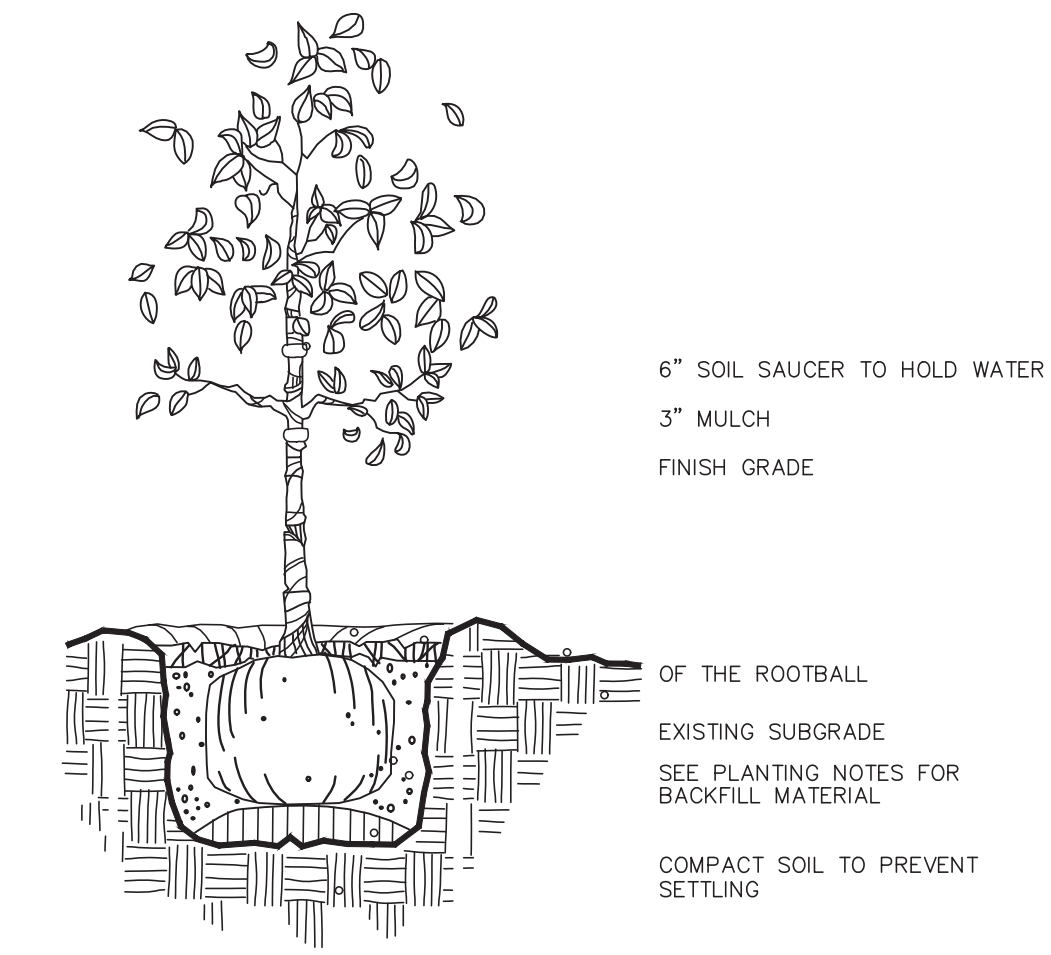

**SMALL TREE PLANTING/STAKING DETAIL**

NOT TO SCALE

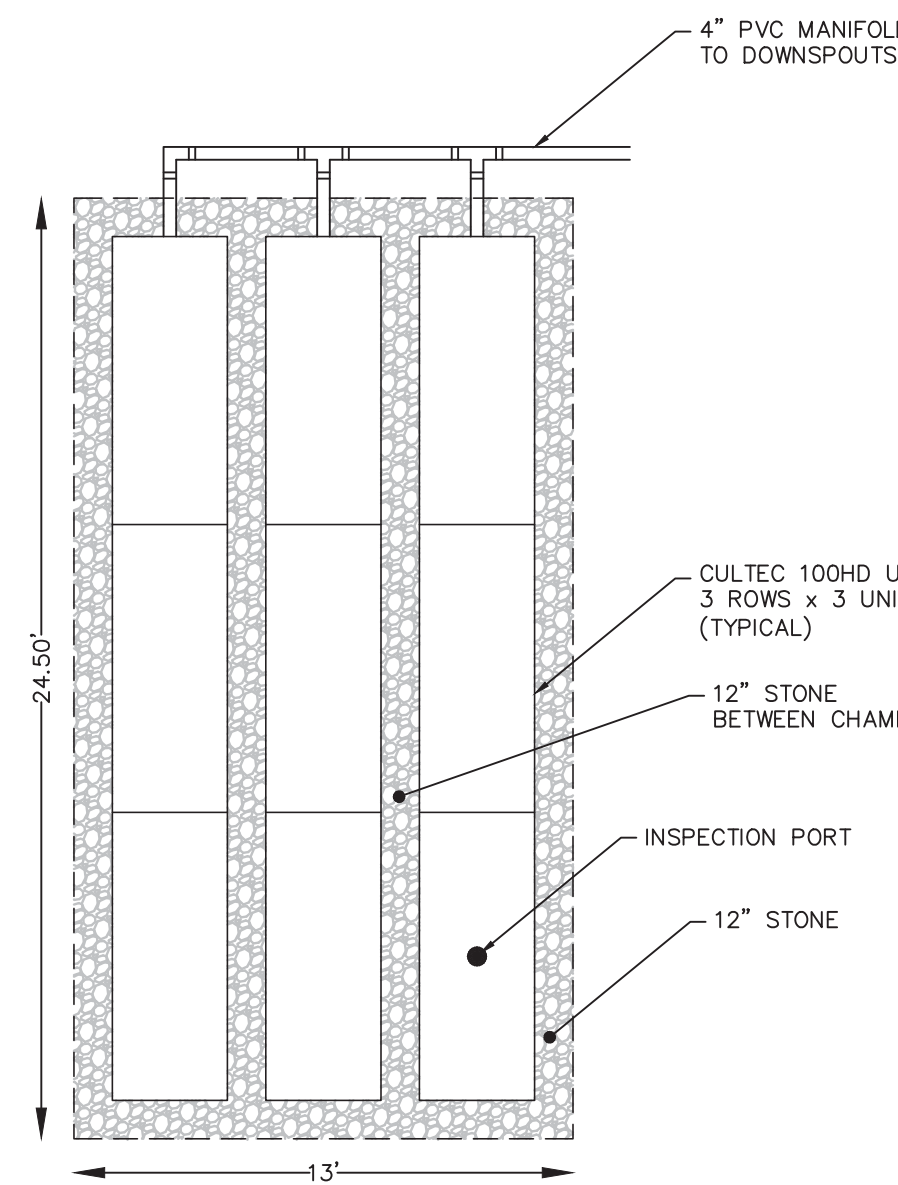

**TYPICAL ROOF DRYWELL**

NOT TO SCALE

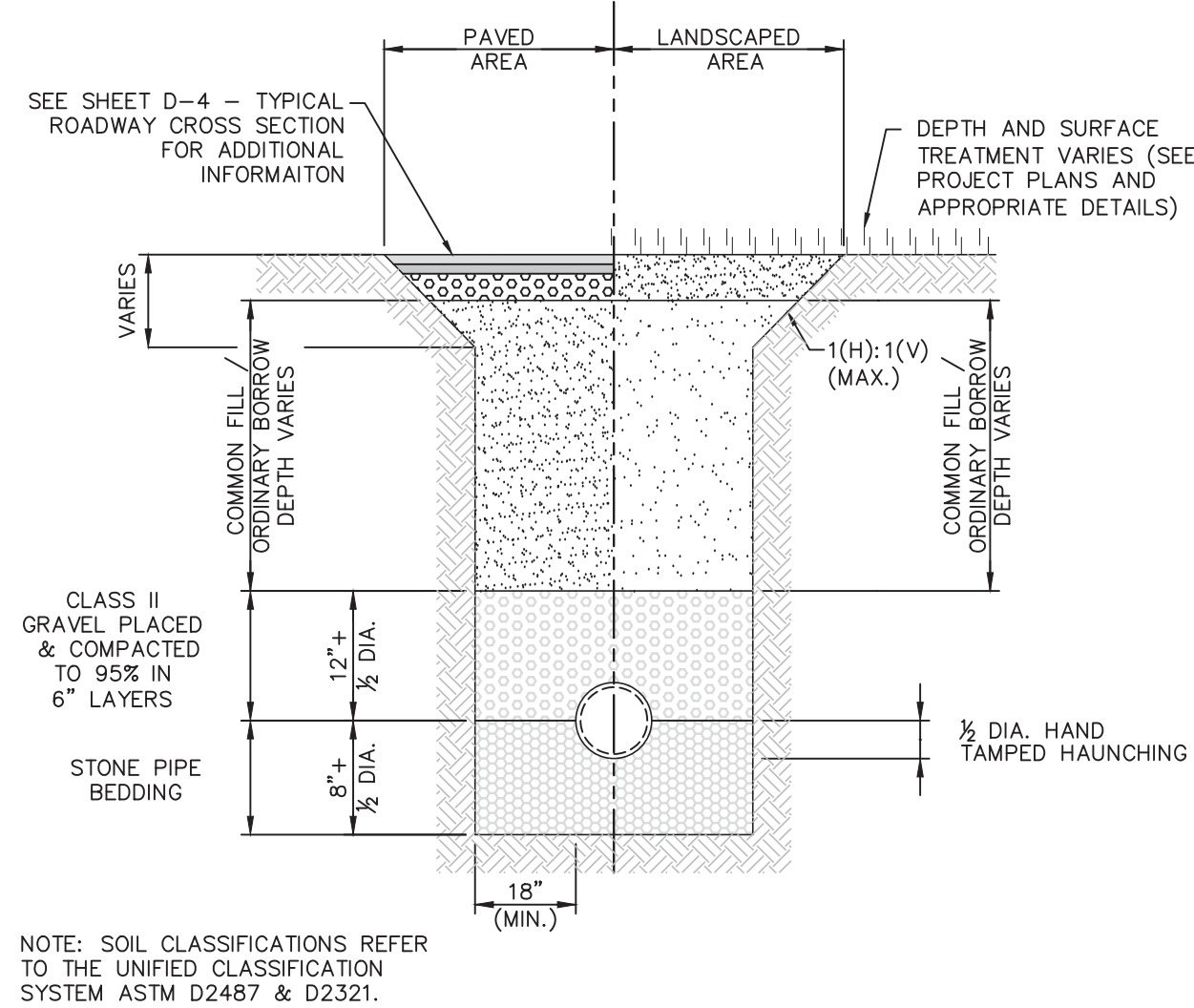

**TYPICAL DRAIN TRENCH**

NOT TO SCALE

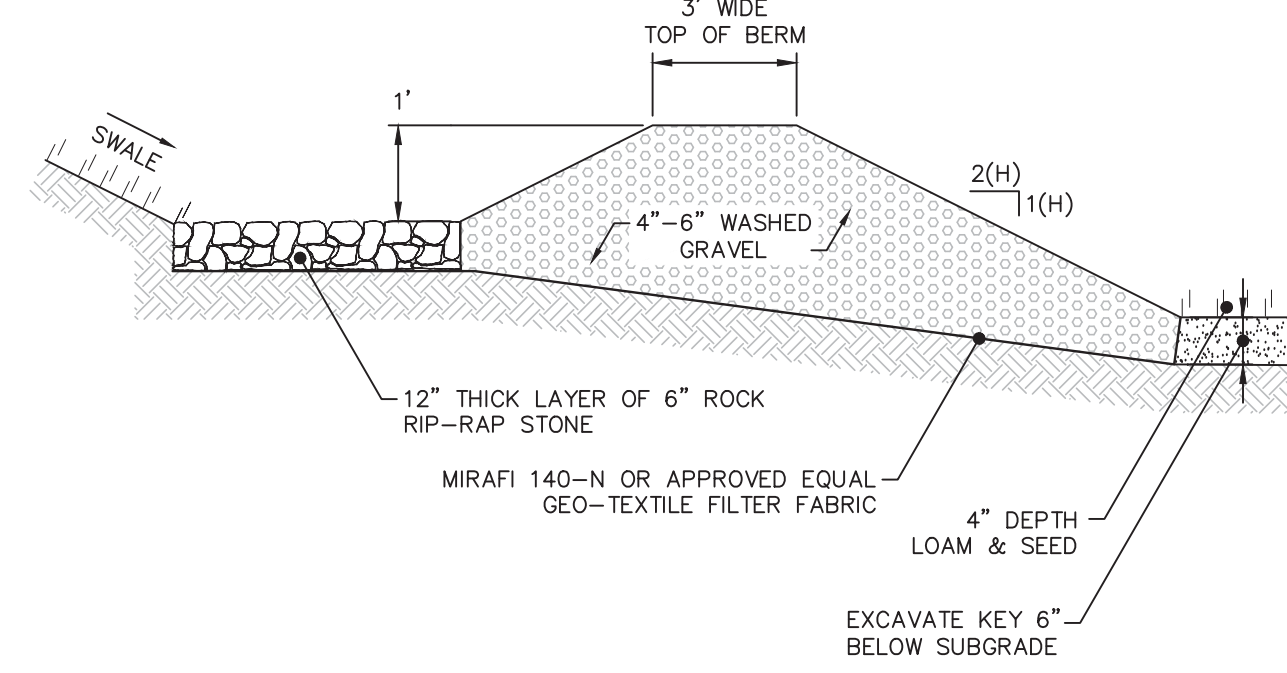

**PROPOSED SEDIMENT BASIN STONE BERM**

NOT TO SCALE

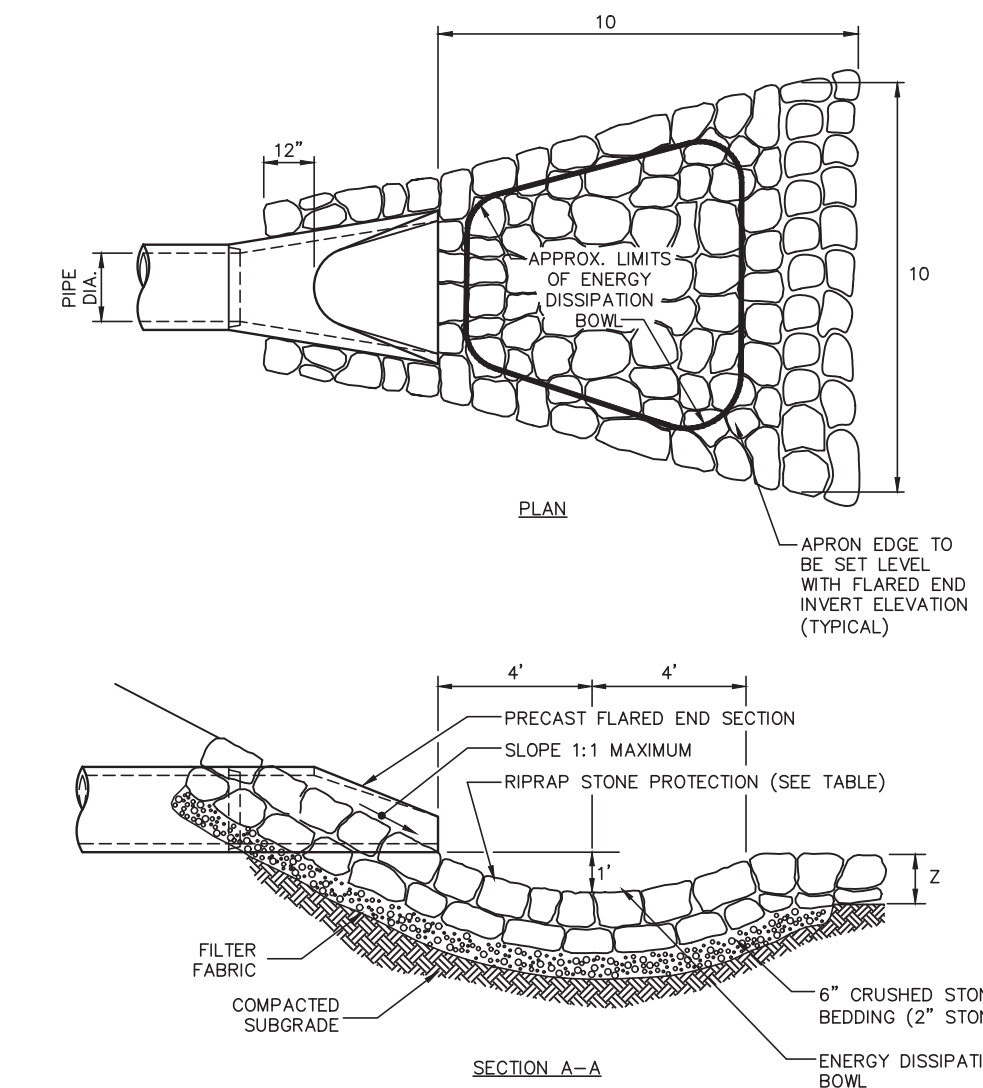

**FLARED END SECTION WITH STONE PROTECTION**

NOT TO SCALE

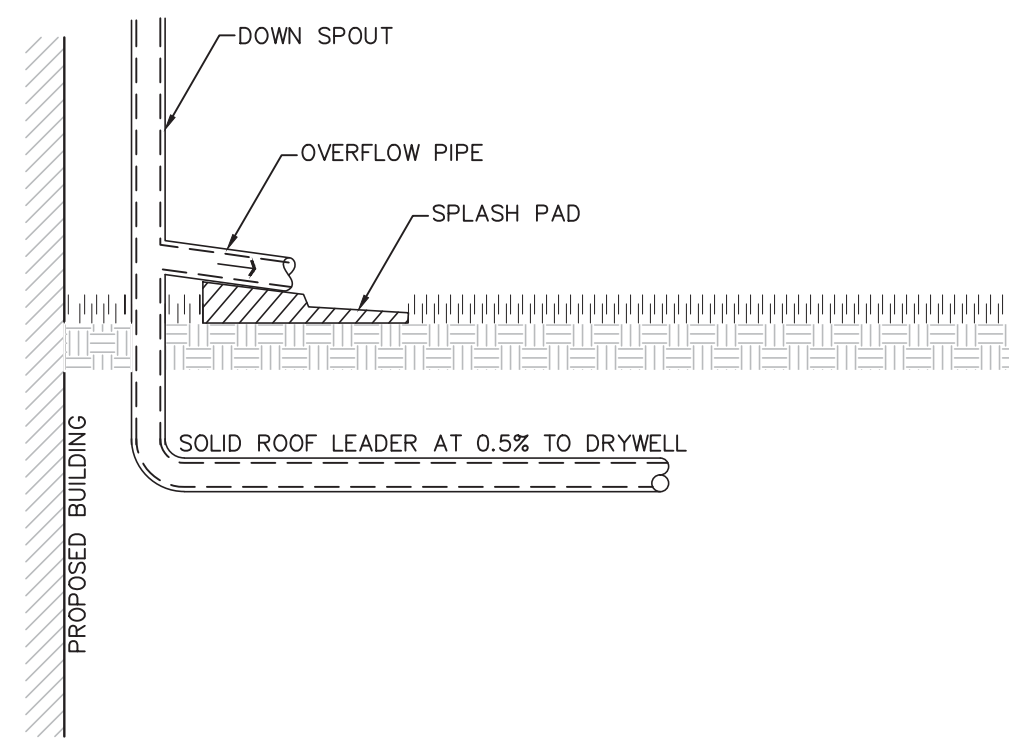

**ROOF DOWNSPOUT DETAIL**

NOT TO SCALE

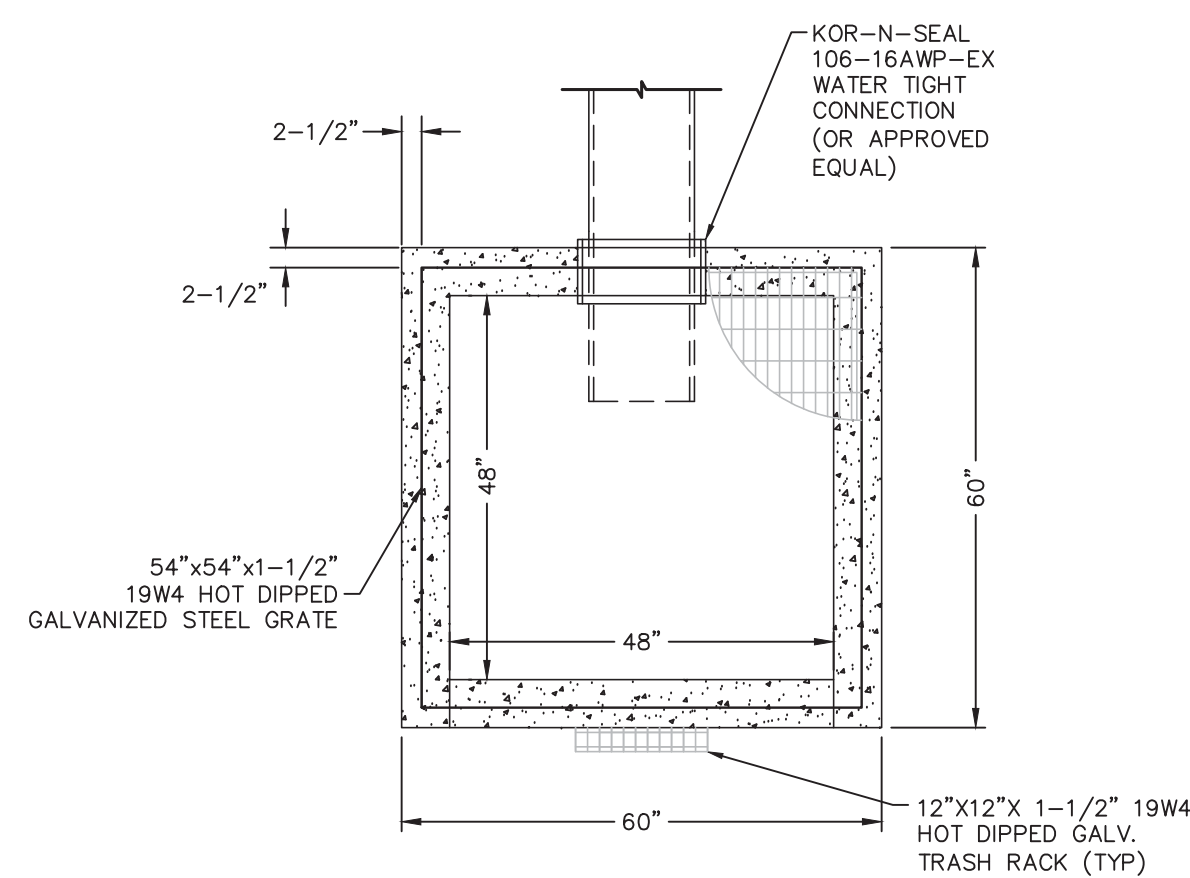

**PLAN**

NOT TO SCALE

OUTLET STRUCTURE CONFIGURATION SUMMARY

|       | A      | B      | C      | D      | E      | F   | G  |
|-------|--------|--------|--------|--------|--------|-----|----|
| POS-1 | 160.00 | 160.22 | 161.00 | 162.00 | 163.00 | 12" | 4" |

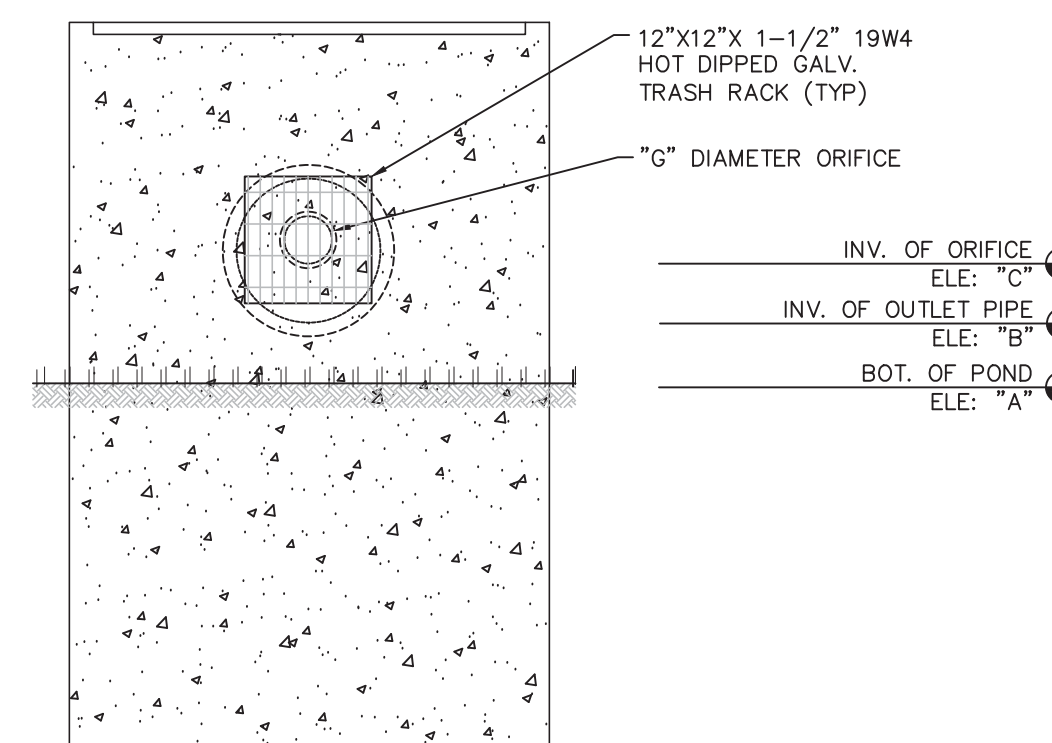

**OUTLET STRUCTURE DETAIL**

NOT TO SCALE

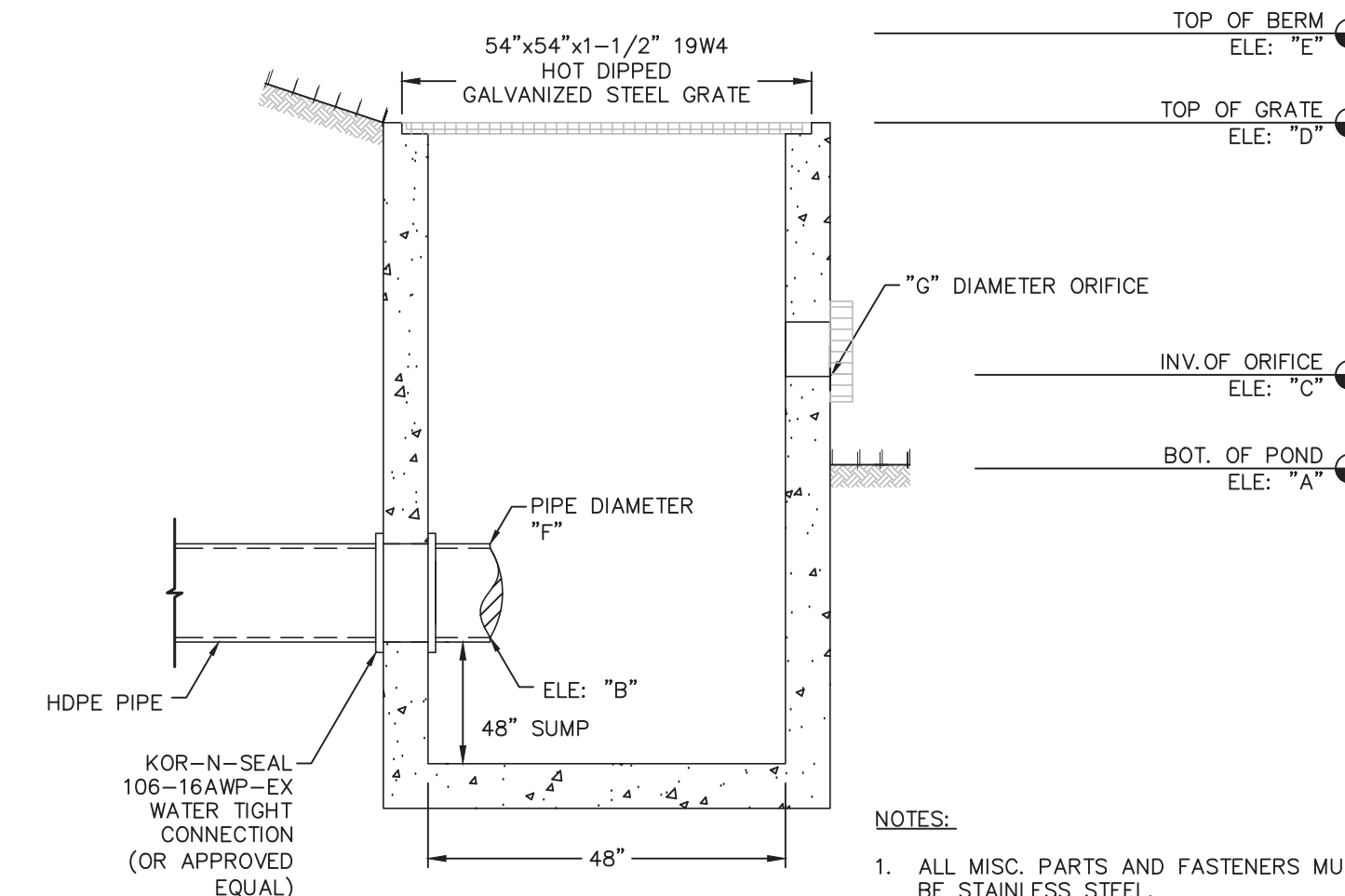

**PROFILE**

NOT TO SCALE

FOR REGISTRY USE ONLY  
THIS PLAN WAS PREPARED IN ACCORDANCE WITH THE RULES AND REGULATIONS FOR RECORDING ADOPTED BY THE REGISTERS OF DEEDS IN 1978 AND AMENDED JANUARY 12, 1988.

ENGINEER: \_\_\_\_\_ DATE: \_\_\_\_\_  
**APPROVED BY THE TOWN OF READING COMMUNITY PLANNING AND DEVELOPMENT COMMISSION**

CERTIFICATE OF ACTION  
DATE OF ENDORSEMENT: \_\_\_\_\_

| DATE     | DESCRIPTION               |
|----------|---------------------------|
| 01/27/20 | REVISIONS PER TOWN REVIEW |
| 11/08/19 | REVISIONS PER TOWN REVIEW |

OWNER / APPLICANT:  
**INFRASTRUCTURE HOLDINGS, LLC**  
122 BOSTON ROAD  
BILLERICA, MA 01862

PROJECT:  
**135, 139 & 149R HOWARD STREET**  
READING, MA 01867

DATE ISSUED: DECEMBER 21, 2018

PROJECT #: 18-10120

PREPARED BY: WILLIAM HALL, P.E.

01/27/20

PROFESSIONAL ENGINEER FOR CIVIL DESIGN CONSULTANTS, INC.

**CIVIL DESIGN Consultants, Inc.**  
SURVEY • DESIGN • PERMITTING • CONSTRUCTION ADMINISTRATION

30 River Street Methuen, MA 01844 Tel: (978) 416-0920 Fax: (978) 416-7865

DRAWING TITLE:  
**CONSTRUCTION DETAILS**

DRAWING #:

**D-2**

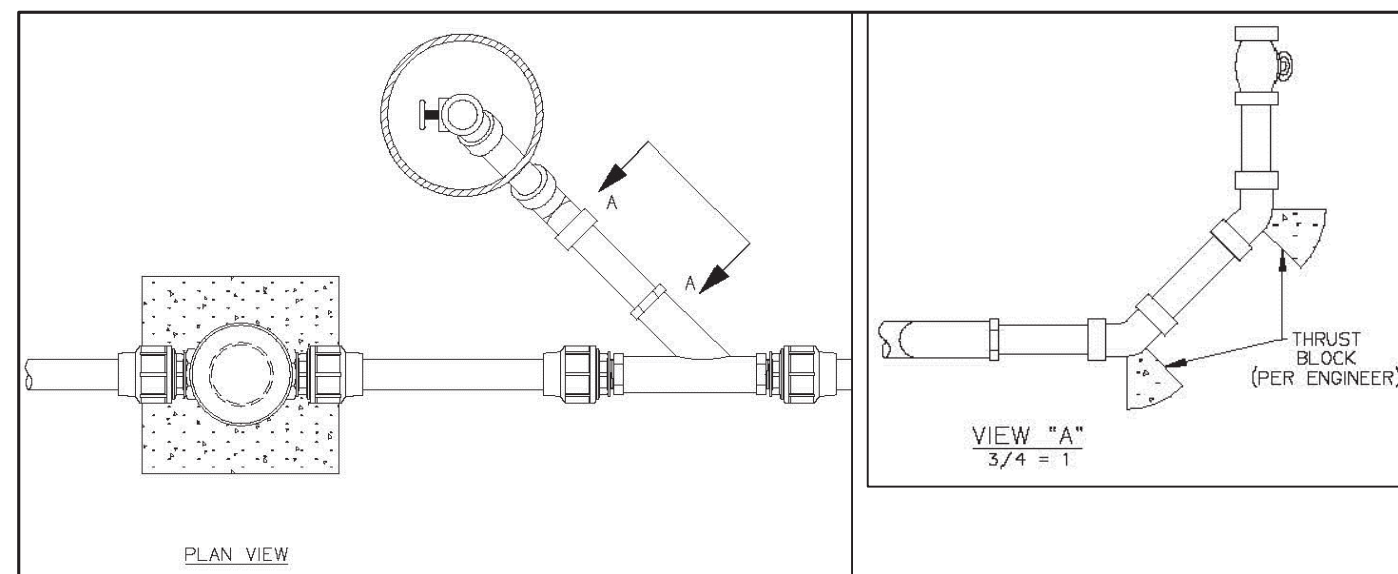

**TYPICAL FLUSHING CONNECTION**

NOT TO SCALE

environment | one  
CORPORATION

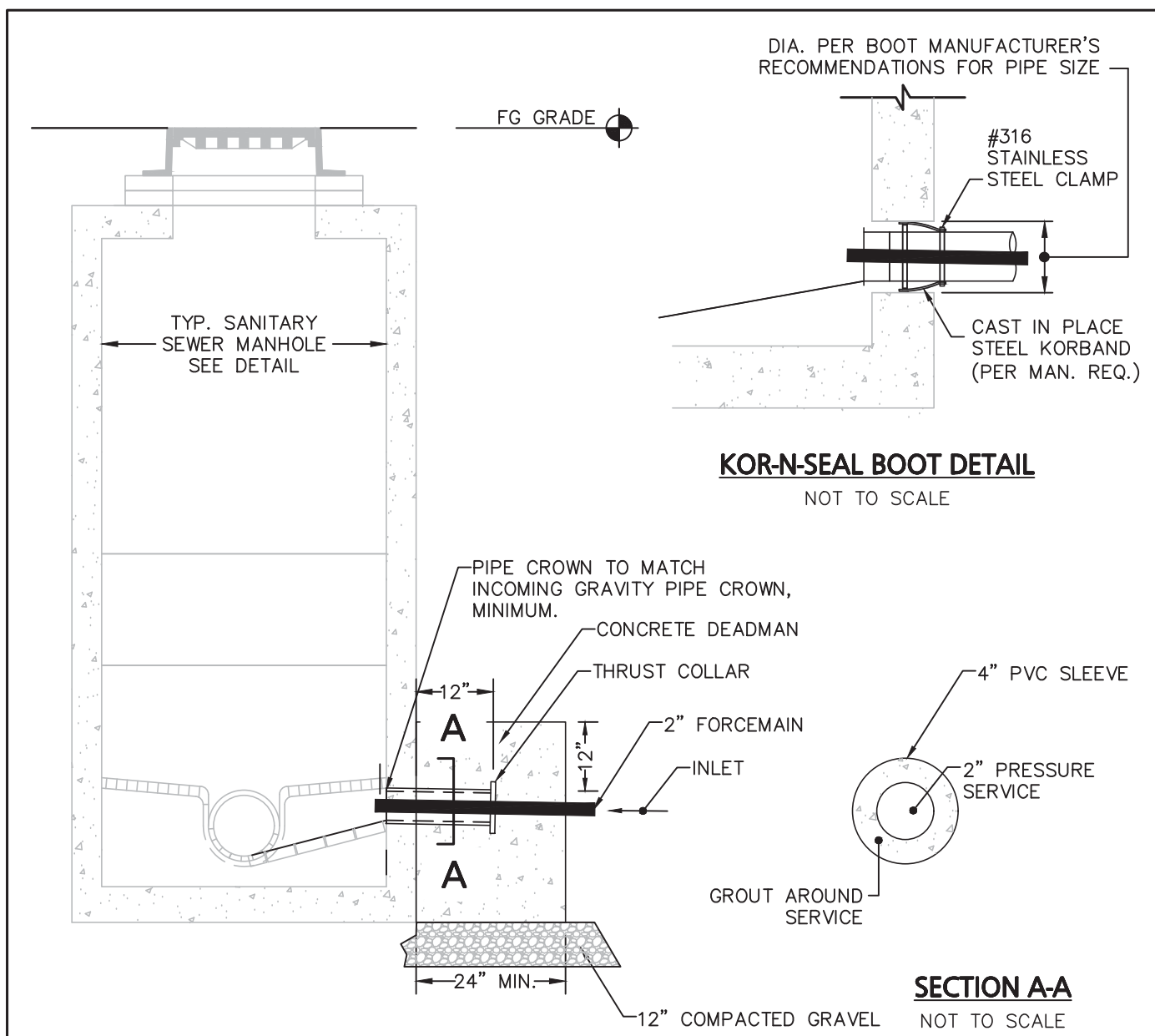

**FORCE MAIN AT PROPOSED SEWER MANHOLE DETAIL**

NOT TO SCALE

environment | one  
CORPORATION

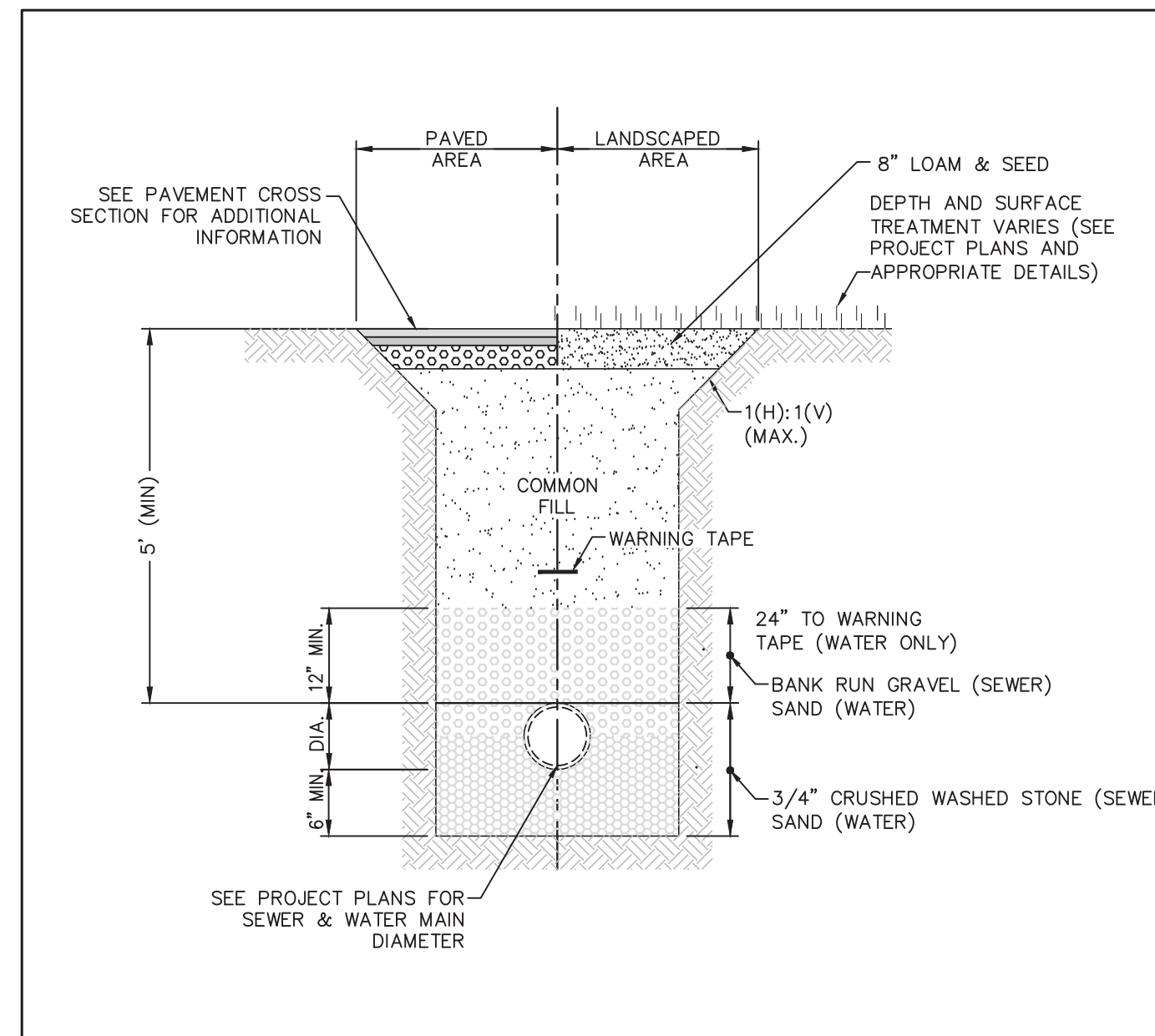

**TYPICAL SEWER & WATER TRENCH**

NOT TO SCALE

environment | one  
CORPORATION

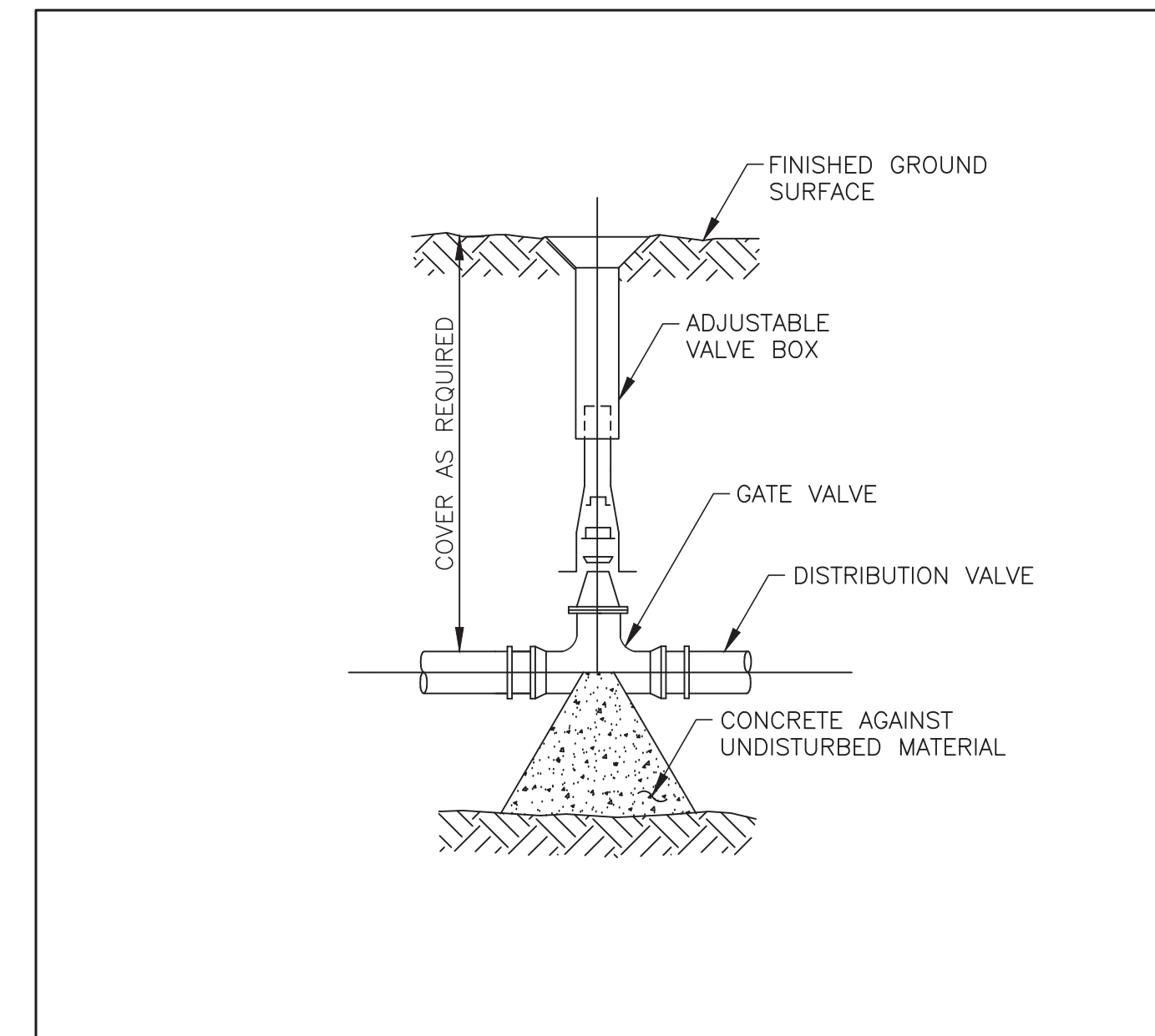

**WATER GATE DETAIL**

NOT TO SCALE

environment | one  
CORPORATION

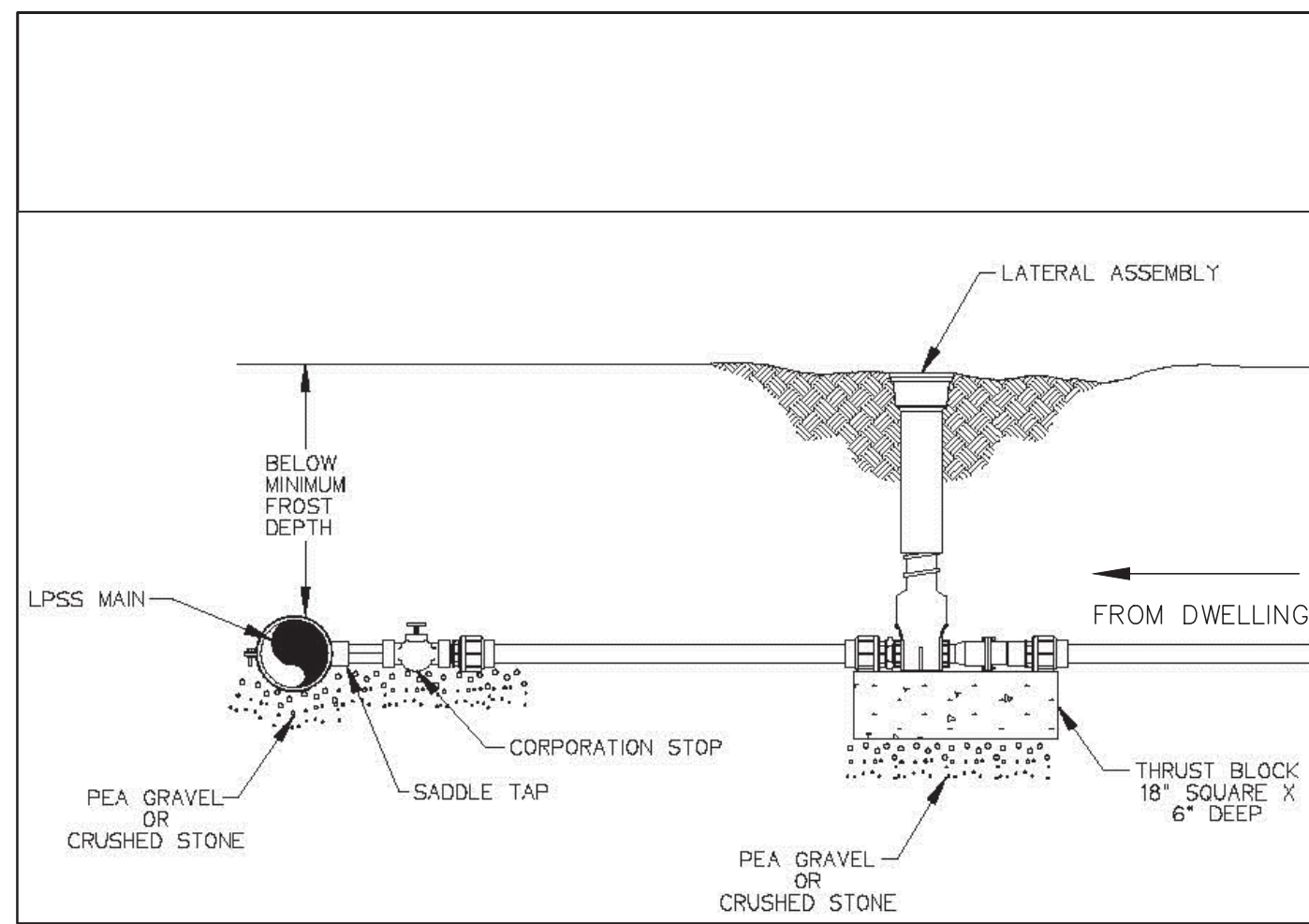

**TYPICAL LATERAL INSTALLATION**

NOT TO SCALE

environment | one  
CORPORATION

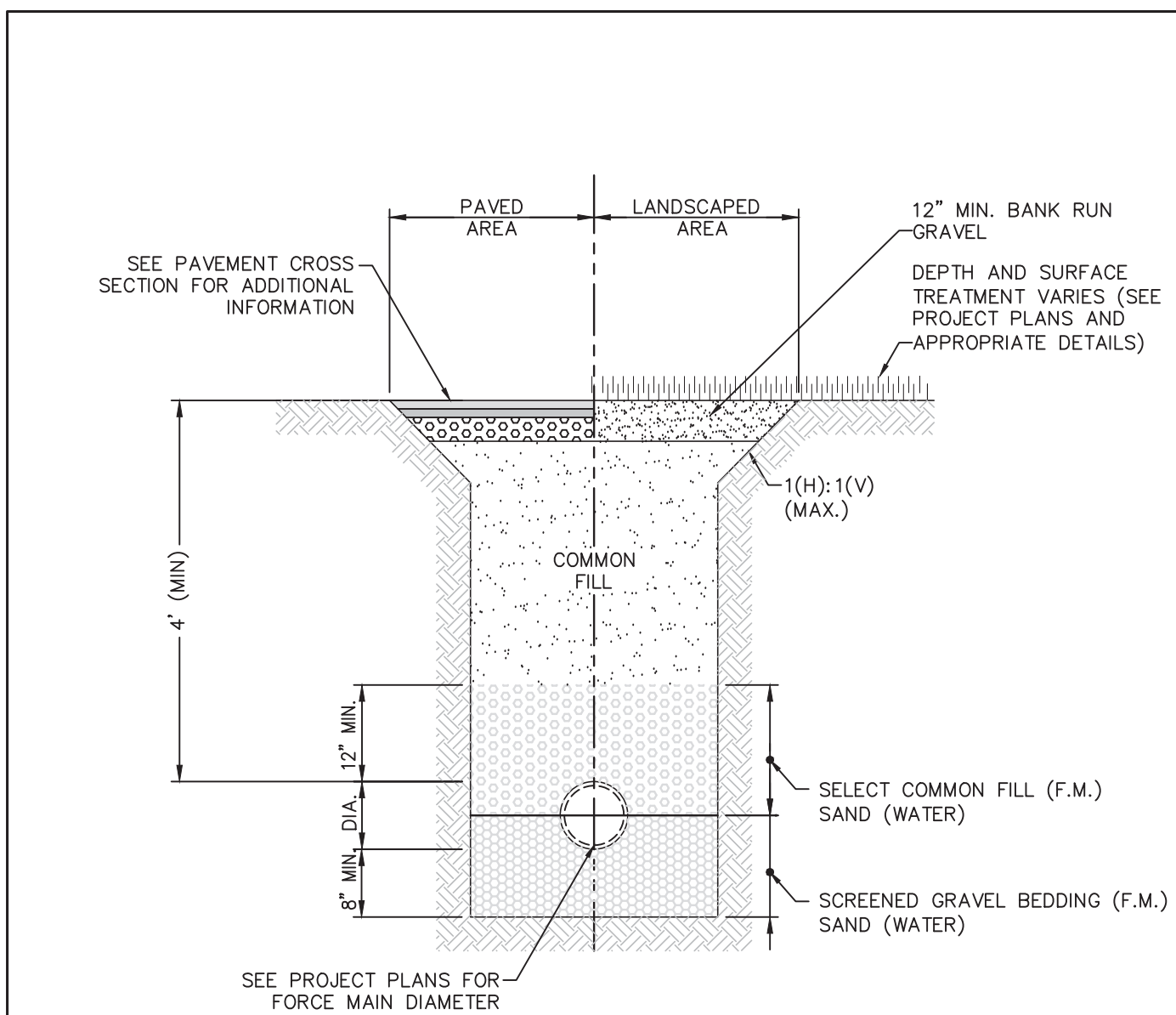

**TYPICAL PRESSURE SEWER SERVICE DETAIL**

NOT TO SCALE

environment | one  
CORPORATION

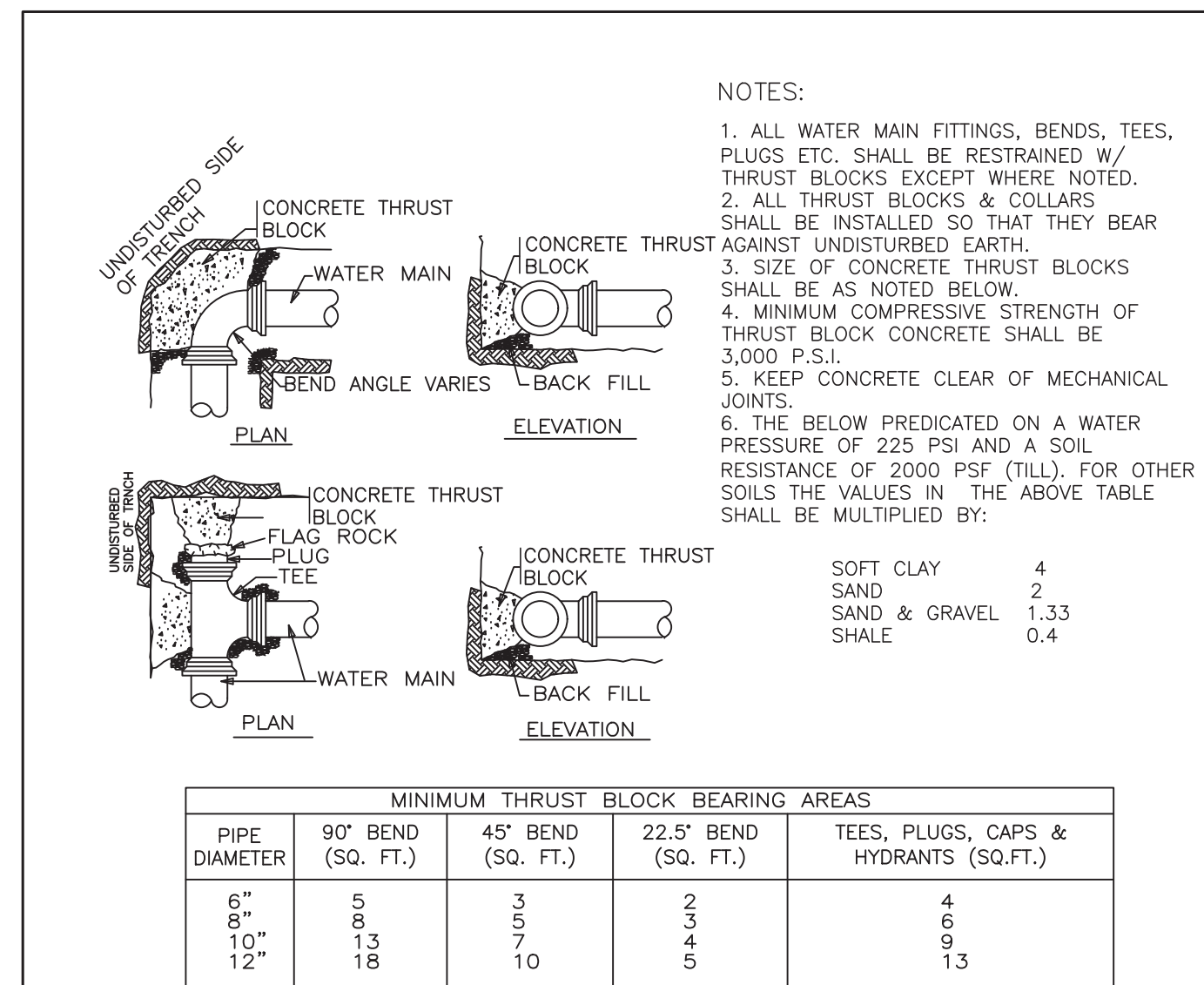

**THRUST BLOCK DETAIL**

NOT TO SCALE

environment | one  
CORPORATION

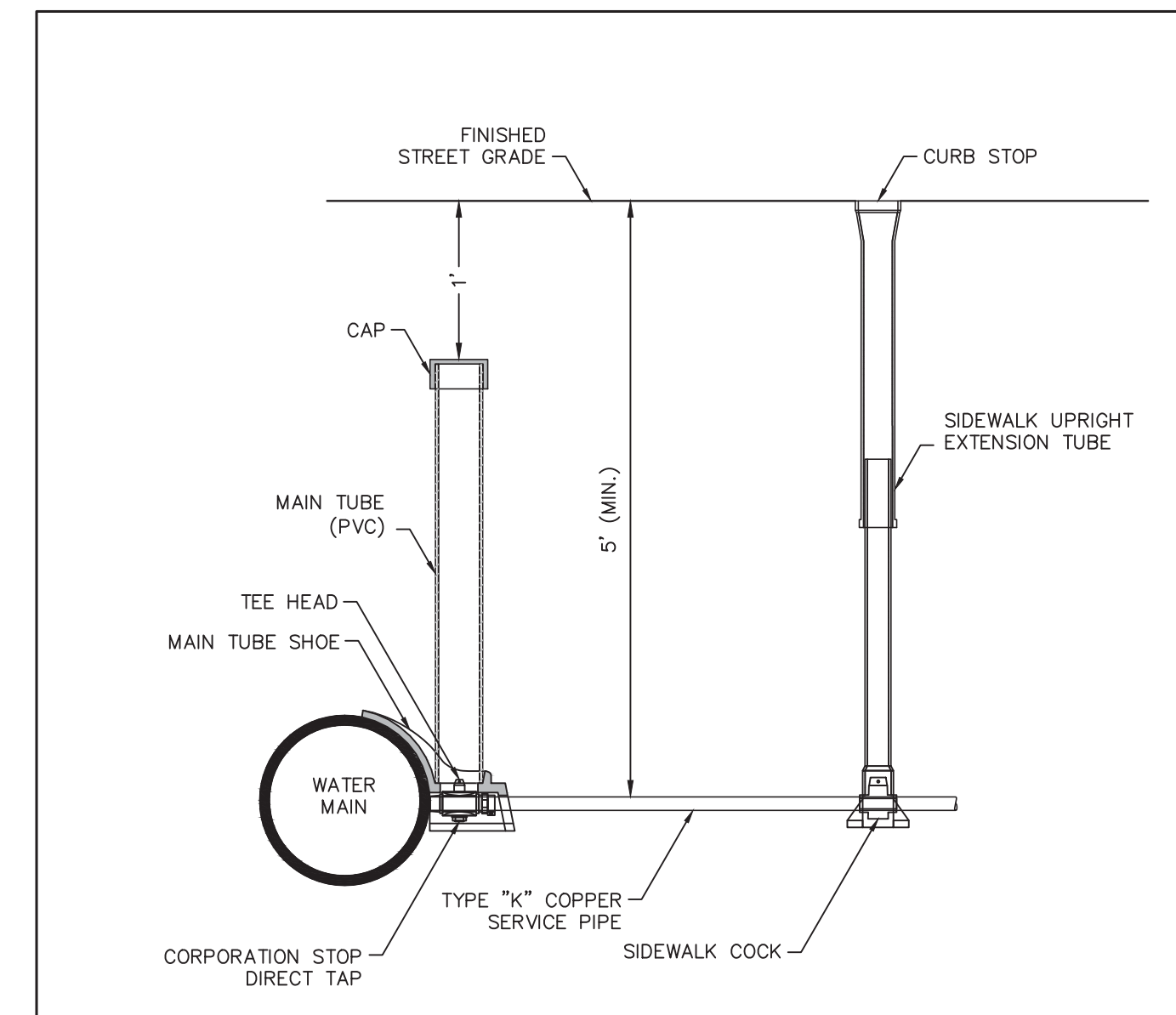

**TYPICAL WATER SERVICE CONNECTION**

NOT TO SCALE

environment | one  
CORPORATION

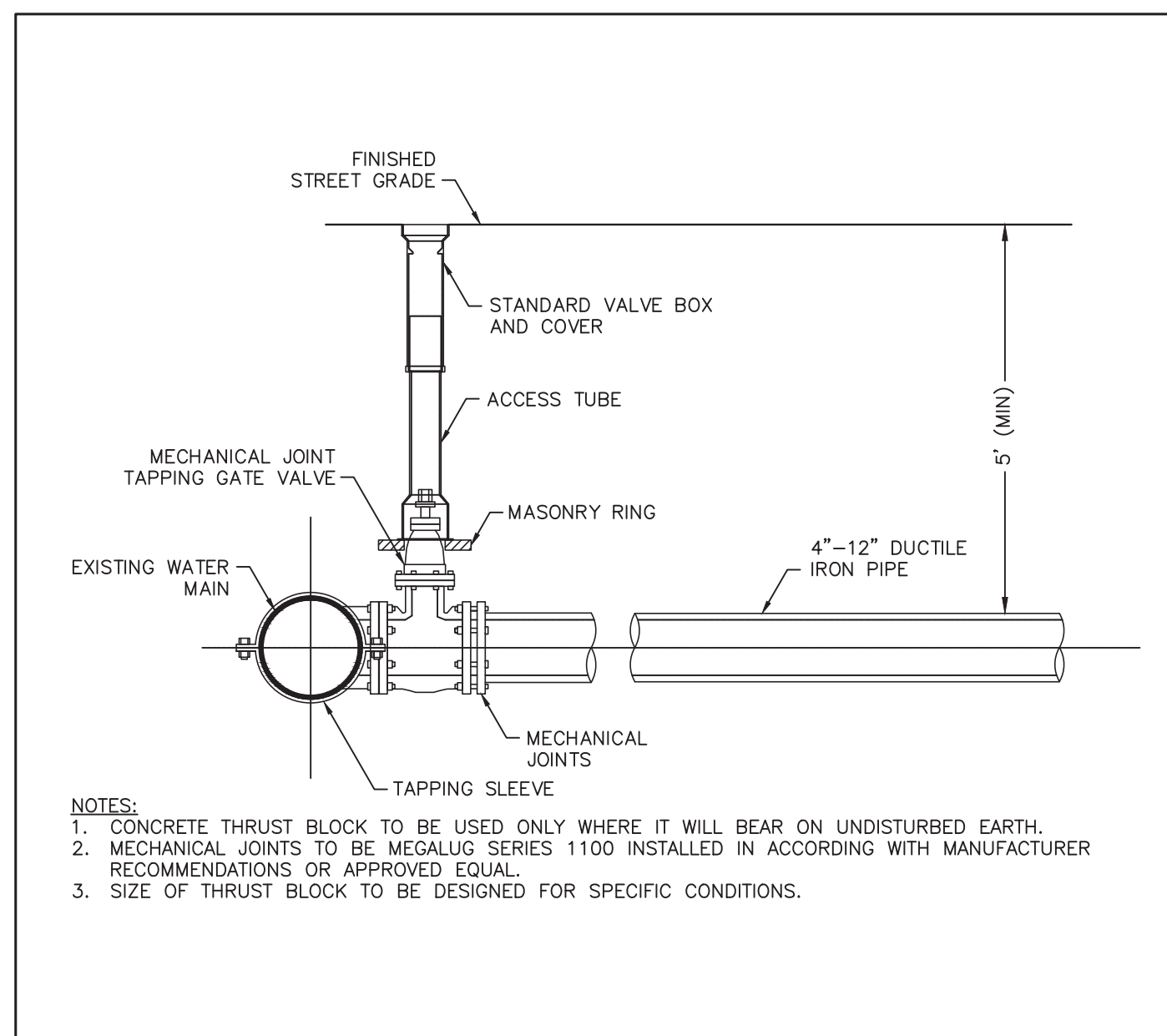

**TYPICAL TAPPING SLEEVE AND VALVE DETAIL**

NOT TO SCALE

environment | one  
CORPORATION

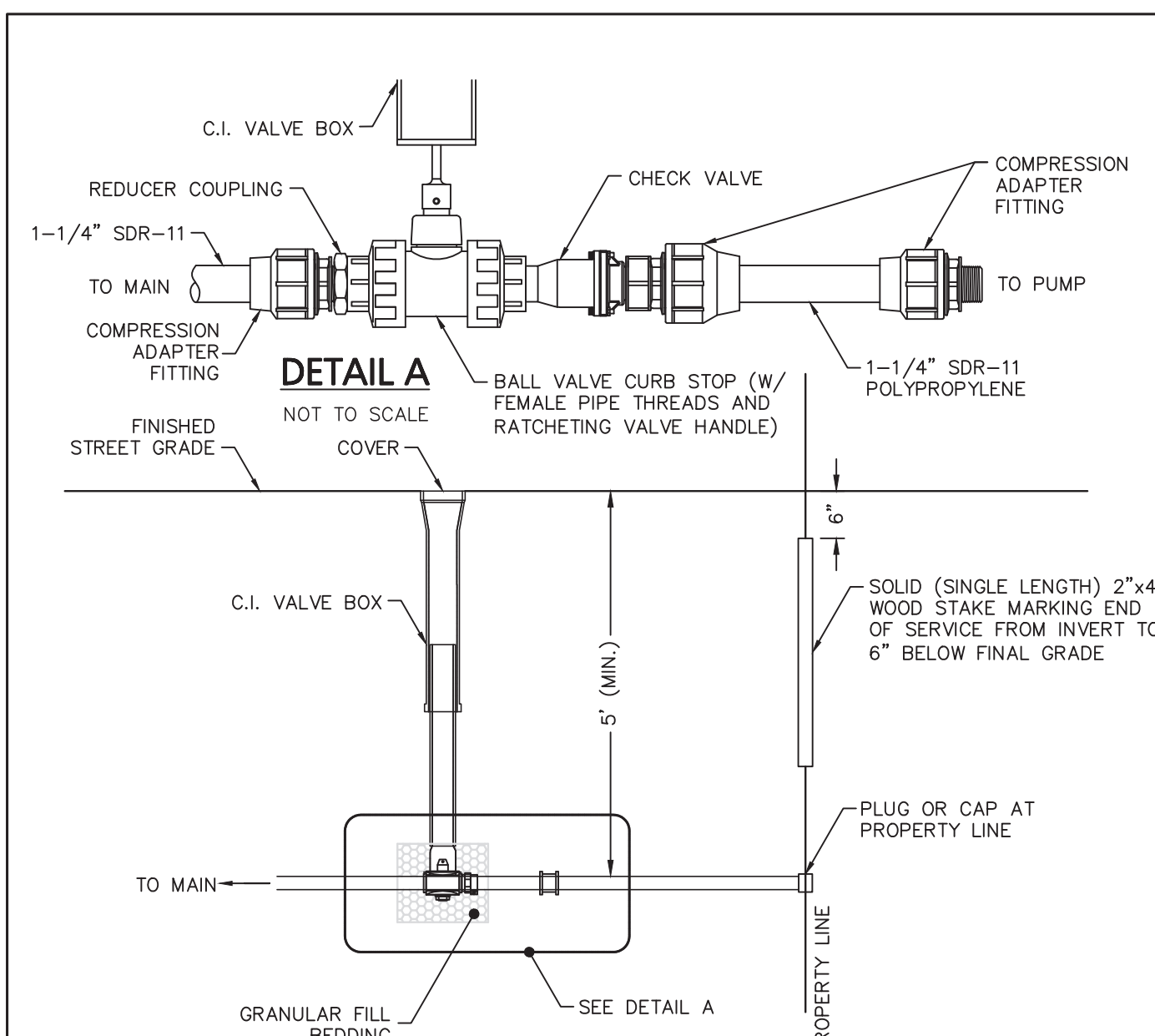

**SERVICE LINE CONNECTION TO FORCE MAIN DETAIL**

NOT TO SCALE

environment | one  
CORPORATION

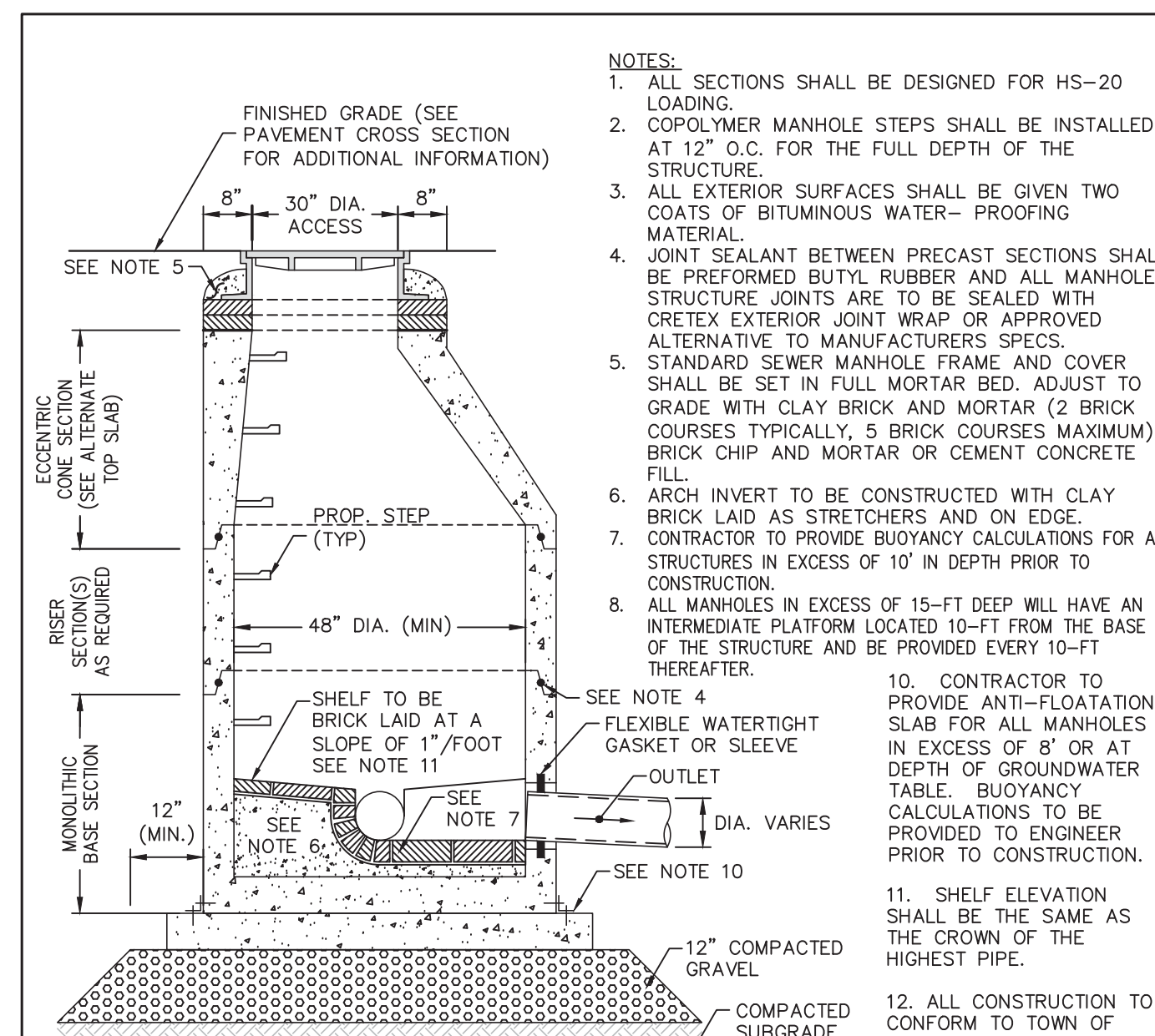

**TYPICAL SANITARY SEWER MANHOLE**

NOT TO SCALE

environment | one  
CORPORATION

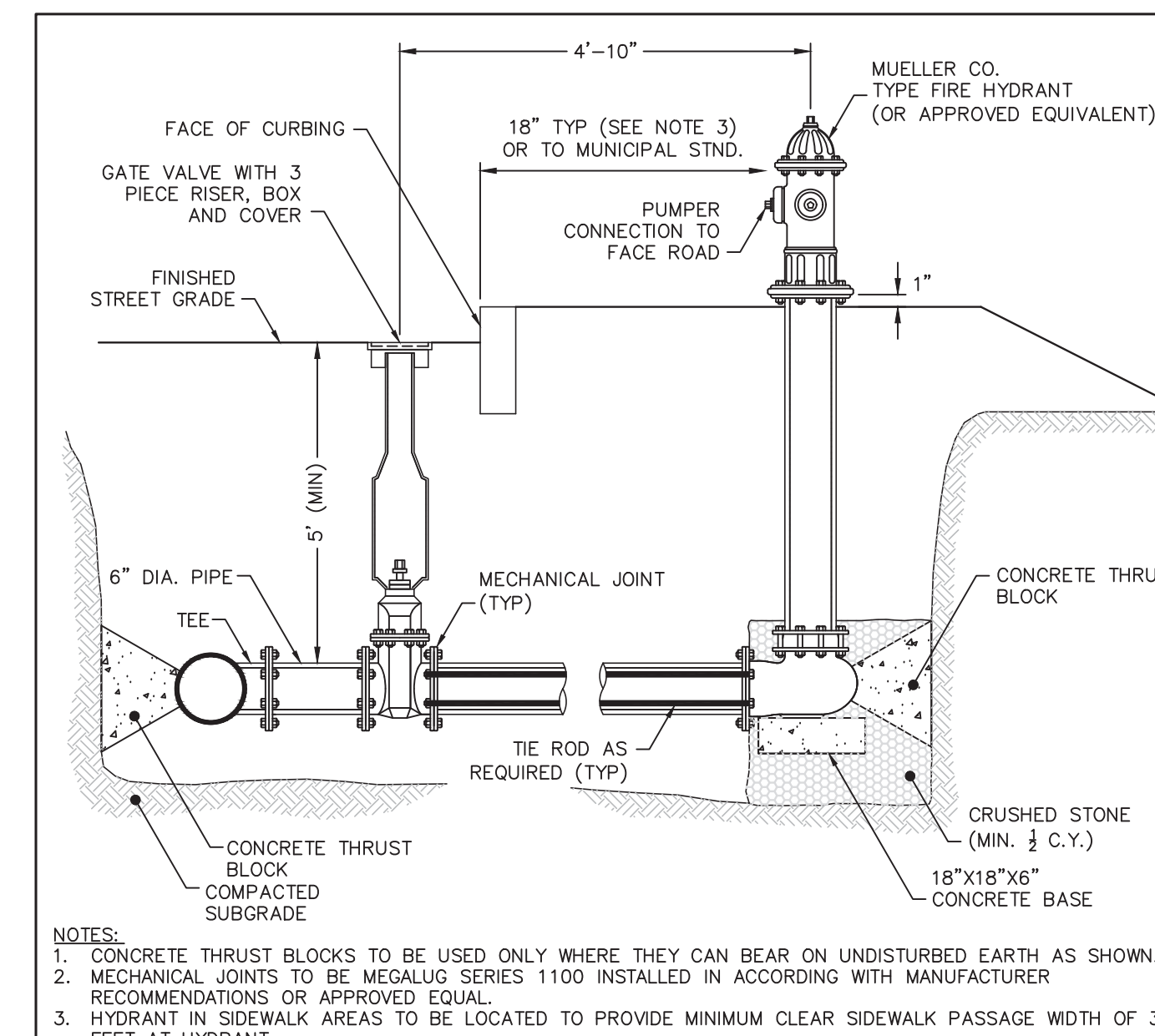

**HYDRANT CONNECTION**

NOT TO SCALE

environment | one  
CORPORATION

FOR REGISTRY USE ONLY  
THIS PLAN WAS PREPARED IN ACCORDANCE WITH THE RULES AND REGULATIONS FOR RECORDING ADOPTED BY THE REGISTERS OF DEEDS IN 1978 AND AMENDED JANUARY 12, 1988.

ENGINEER DATE  
**APPROVED BY THE TOWN OF READING COMMUNITY PLANNING AND DEVELOPMENT COMMISSION**

CERTIFICATE OF ACTION  
DATE OF ENDORSEMENT

01/27/20 REVISIONS PER TOWN REVIEW  
11/08/19 REVISIONS PER TOWN REVIEW  
DATE DESCRIPTION  
REVISIONS

OWNER / APPLICANT:  
**INFRASTRUCTURE HOLDINGS, LLC**  
122 BOSTON ROAD  
BILLERICA, MA 01862

PROJECT:  
**135, 139 & 149R HOWARD STREET**  
READING, MA 01867

DATE ISSUED: DECEMBER 21, 2018

PROJECT #: 18-10120

PREPARED BY: WILLIAM HALL, P.E.

01/27/20

PROFESSIONAL ENGINEER FOR CIVIL DESIGN CONSULTANTS, INC.

**CIVIL DESIGN Consultants, Inc.**  
SURVEY • DESIGN • PERMITTING • CONSTRUCTION ADMINISTRATION

30 River Street Methuen, MA 01844 Tel: (978) 416-0920 Fax: (978) 416-7865

DRAWING TITLE:  
**CONSTRUCTION DETAILS**

DRAWING #:

**D-3**

