

MEMORANDUM

Subject: Response to NOI Comments

Project: **Town of Reading | Birch Meadow Phase II**
Project No. 24037.00

Date: 16 April 2025

To: Reading Conservation Commission
c/o Charles Tirone
Reading Conservation Administrator

By: Holly Ganser, PE
Civil Project Manager

Delivery: via Email

Distribution: Ryan Percival, Town of Reading (via email) Steve Crisafulli, Activitas

Dear Commissioners,

The following are our responses to comments received during the hearing for the Notice of Intent filing for the Birch Meadow Phase II Project. The comments are provided for reference, and our responses are in **bold**. We look forward to discussing the project further with the Conservation Commission.

Revise NOI Project Narrative to clarify two basketball courts will replace the existing basketball court and pickleball courts.

Please see revised NOI Project Narrative. The Stormwater Report project narrative has also been revised to match the same language and updated section has been provided.

Revise Site Preparation Plan to identify trees to be removed, transplanted, or protected.

The Site Preparation Plan has been revised to better indicate which trees will be removed, transplanted, or protected as part of the project. An additional plan specific to tree removals has also been provided.

Revise limit of erosion control at Longfellow Road to allow existing drainage down street to flow into drainage way.

Please see revised Site Preparation Plan that adjusts the limits of erosion controls at Longfellow Road.

Call out memorial bench to be protected or relocated next to Longfellow Road connection.

Please see the revised Site Preparation Plan which calls for protection of the memorial bench.

Add construction entrance to plans.

Please see the revised Site Preparation Plan which adds the proposed location for the construction entrance.

Add material stockpile locations to plans.

Please see the revised Site Preparation Plan which adds anticipated location for material stockpiles on site.

Revise proposed plant list to include plants on recommended native plant list.

Please see the revised Planting Schedule on L3.2 which has removed all non-native species.

Clarify perforated pipes vs solid drain pipes on the grading and utility plan.

Please see revised sheet L2.1 which updates the line types for the different drain lines for better clarity.

Provide more detail about lighting and cutoffs for lighting and timing of lights.

Please refer to the revised presentation for the photometric plan which indicates nearly a complete 0.0 footcandle cutoff at the wetland edge. This does not account for vegetation/tree coverage, which further reduces light spillage. The proposed LED sports lights will be regulated according to a schedule that will be reviewed by the Town and the Recreation Department to minimize disruption to both the neighborhood and the environment.

Provide stormwater checklist for drainage for the modular unit portion of the project.

Please refer to response/documentation provided by Hancock Associates.

Revise drainage calculations between the modular unit portion of the project and the Birch Meadow Park portion of the project to reflect the same design storm.

The modular unit project has updated their design storms to match the Birch Meadow Park site portion of the project, which utilizes the Atlas-14 methodology per the request of Reading Engineering. Please refer to response/documentation provided by Hancock Associates.

We hope these responses adequately address comments received during the NOI Project Hearing and look forward to discussing the project at the April 23, 2025, Conservation Commission Meeting.

Respectfully,

ACTIVITAS

Holly Ganser, PE
Civil Project Manager
hcg@activitas.com

Revision Attachments:

- Revised NOI Report – Cover Page and Project Description Section
- Revised Stormwater Report – Cover Page and Project Overview Section
- Revised Project Drawings Dated 4/15/25
 - Cover
 - SP1.1 – Site Preparation and Erosion Control Plan
 - SP1.2 – Site Preparation Details
 - L2.1 – Grading and Utility Plan
 - L3.1 – Planting Plan
 - L3.2 – Planting Details and Schedules
- Sheet LX.X – Tree Protection and Removals Plan (reference plan)
- Conservation Commission Meeting 2 Presentation Dated 4/23/25
- Drainage Memo – Reading High School Modular Classroom Relocation
- Stormwater Checklist for Reading High School Modular Classroom Relocation
- Detail Sheet C3 – detail #9 shows the detail for stone under the modular units

Notice of Intent

Birch Meadow Park Phase II

0 Bancroft Avenue - 0 Birch Meadow Drive
Reading, MA, 01867



Owner:

Town of Reading
16 Lowell Street
Reading, MA 01867

Civil Engineer/ Landscape Architect:

Activitas, Inc.
70 Milton Street
Dedham, MA 02026
(781) 355-7040

Submitted To:

Town of Reading
Conservation Commission
16 Lowell Street
Reading, MA 01867

Survey:

Reed Land Surveying
109 Rhode Island Road, Suite 4A
Lakeville, MA 02347
(508) 923-1191

March 26, 2025; April 15, 2025

Project Description

The Town of Reading is proposing to renovate areas at Birch Meadow Park. Renovations include demolition of the existing asphalt basketball court and pickleball courts and constructing two (2) new post-tension concrete basketball courts in their place. Additional improvements include renovations to the existing playground area to include new playground equipment and replacing the existing shredded tire mulch surfacing with poured-in-place playground surfacing. Additional site improvements include construction of two new formalized handicap parking spaces, renovating and extending accessible walkways to provide access to the playground, basketball courts, and parking areas as well as associated drainage improvements. These improvements are to provide quality athletic and recreational facilities along with improved handicap accessibility throughout the park area.

The project limits include the existing parking lot located to the east of the site, a Bordering Vegetated Wetland along Hartshorn Street to the south, existing baseball fields and tennis courts to the north, and Bancroft Avenue to the west. The project will also include resurfacing of the poured-in-place surface at the RISE preschool playground behind the high school and across the driveway from Birch Meadow Park. This portion of the project is included in the enclosed project drawings; however, it is not discussed further as it is outside jurisdictional areas of the Conservation Commission.

The project is subject to the Wetlands Protection Act (310 CMR 10.02 (2) (b) and (c)) and the Town of Reading Wetlands Protection Regulations as work falls within previously disturbed areas of the 100-foot Buffer Zone to Bordering Vegetated Wetlands (BVW). There is some work within 35' of the BVW as well which is the No-Structure Zone outlined in the regulations. The work within this area is also within previously disturbed area. A request to reduce the width of this setback is included in the submission. No work is proposed within the BVW.

Refer to the Proposed Site Plan dated March 17, 2025, for more detailed information about the project.

Stormwater Report

Town of Reading Birch Meadow Park Phase II

0 Bancroft Avenue – 0 Birch Meadow Drive
Reading, MA, 01867

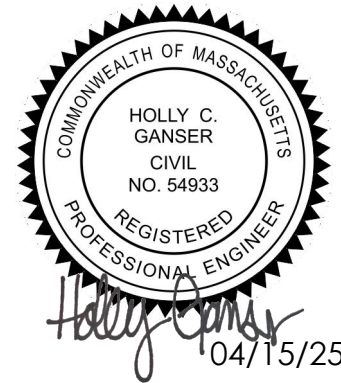

Owner:

Town of Reading
16 Lowell Street
Reading, MA 01867

Civil Engineer/ Landscape Architect:

Activitas, Inc.
70 Milton Street
Dedham, MA 02026
(781) 355-7040

Submitted To:

Town of Reading
Conservation Commission
16 Lowell Street
Reading, MA 01867

Surveyor:

Reed Land Surveying, Inc.
109 Rhode Island Road, Suite 4A
Lakeville, MA 02347
(508) 923-1181

Project Overview

The Town of Reading proposes the following renovations to Reading's Birch Meadow Park Facility located at 0 Birch Meadow Lane, Reading, MA.

BASKETBALL COURTS

Renovations include demolition of the existing asphalt basketball court and pickleball courts and constructing two (2) new post-tension concrete basketball courts in their place. Post-tension concrete pavement has 20+ year warranties before anticipated cracking would appear in the surface. The courts will have 10' high chain link fence at each endline and partially up the side lines to help contain basketballs within the playing area. The project will replace the existing athletic court lighting with new LED athletic lighting the upgraded lighting will allow for better control of the spill of light and will contain closer to the court area over the existing lighting.

PLAYGROUND

The renovations will renovate the existing playground area to include new equipment suited for children ages 2-12 and poured-in-place surfacing. The perimeter of the playground will have a 4' high ornamental fence.

NEW ADA PARKING

The project proposes to build two (2) accessible parking spaces (include one van space) and associated access aisle at Bancroft Ave south of the existing parking spaces adjacent to the tennis courts. Currently the closest accessible parking spot is in the parking lot on the Reading Memorial High School side of the Birch Meadow Park facility. Siting of the new ADA spaces in this location provides more direct ADA access to the playground and basketball courts and generally provides more accessibility to Birch Meadow Park as a whole.

OTHER IMPROVEMENTS

The project also proposes additional site, landscape and drainage improvements. ADA accessible walkways will connect the proposed site elements to each other, the adjacent parking areas, and other elements of the entire Birch Meadow Park facility. In addition to the athletic lighting at the basketball courts, site lighting will be installed along the pathways. The design of the new proposed work and construction will protect the existing trees on site to the extent practicable and is proposing to plant 10 new trees.

The proposed project will disturb approximately 61,694 sf (1.14 acres) and will increase the impervious area within the limit of work by 4,655 square feet. A portion of the proposed project work is located within the 100' buffer of an adjacent offsite wetland.

Compliance with Stormwater Standards

The Town of Reading utilizes the policy, criteria and information including specifications and standards of the Massachusetts Department of Environmental Protection Stormwater Handbook (MA Stormwater Handbook dated 2/2008). The proposed project is considered new development under the Stormwater Standards. The project has been designed in accordance with the "Massachusetts Stormwater Handbook" and the Town of Reading's Wetland Protection Regulations.

LID Measures

Key features of Low Impact Development (LID) stormwater management systems include implementing practices that maintain a site's existing hydrology, using decentralized practices to manage stormwater close to the source of generation, and maximizing onsite infiltration to reduce runoff and landscape watering requirements.

TREE PLAN LEGEND

- TREE TRANSPLANT BY TOWN
- TREE REMOVAL BY TOWN
- TREE PROTECTION BY CONTRACTOR

CONSERVATION COMMISSION REFERENCE PLAN ONLY - NOT A WORKING CONSTRUCTION DOCUMENT

ACTIVITAS
 landscape architecture | civil engineering
 70 Milton Street | Dedham, MA 02026-2915
 (781) 326-2600 | activitas.com

CONSULTANTS

ELECTRICAL ENGINEER -
 NVS ENGINEERS

SURVEY -
 REED LAND SURVEY, INC.

TOWN OF READING
 Reading, MA

BIRCH MEADOW PARK | PHASE II RENOVATIONS

90% Design Development/
Permitting - March 17, 2025

REVISIONS:

NO.	DATE	DESCRIPTION

SCALE: 1"=30'-0"

PROJECT NO.: 24037.00

FILE: 24037.00-LX-X-TREE_PLAN.dwg

DRAWN: AJA

CHECKED: SRC/HCG

SEAL:

SHEET TITLE:

TREE PROTECTION AND REMOVALS PLAN

SHEET NO:

LX.X

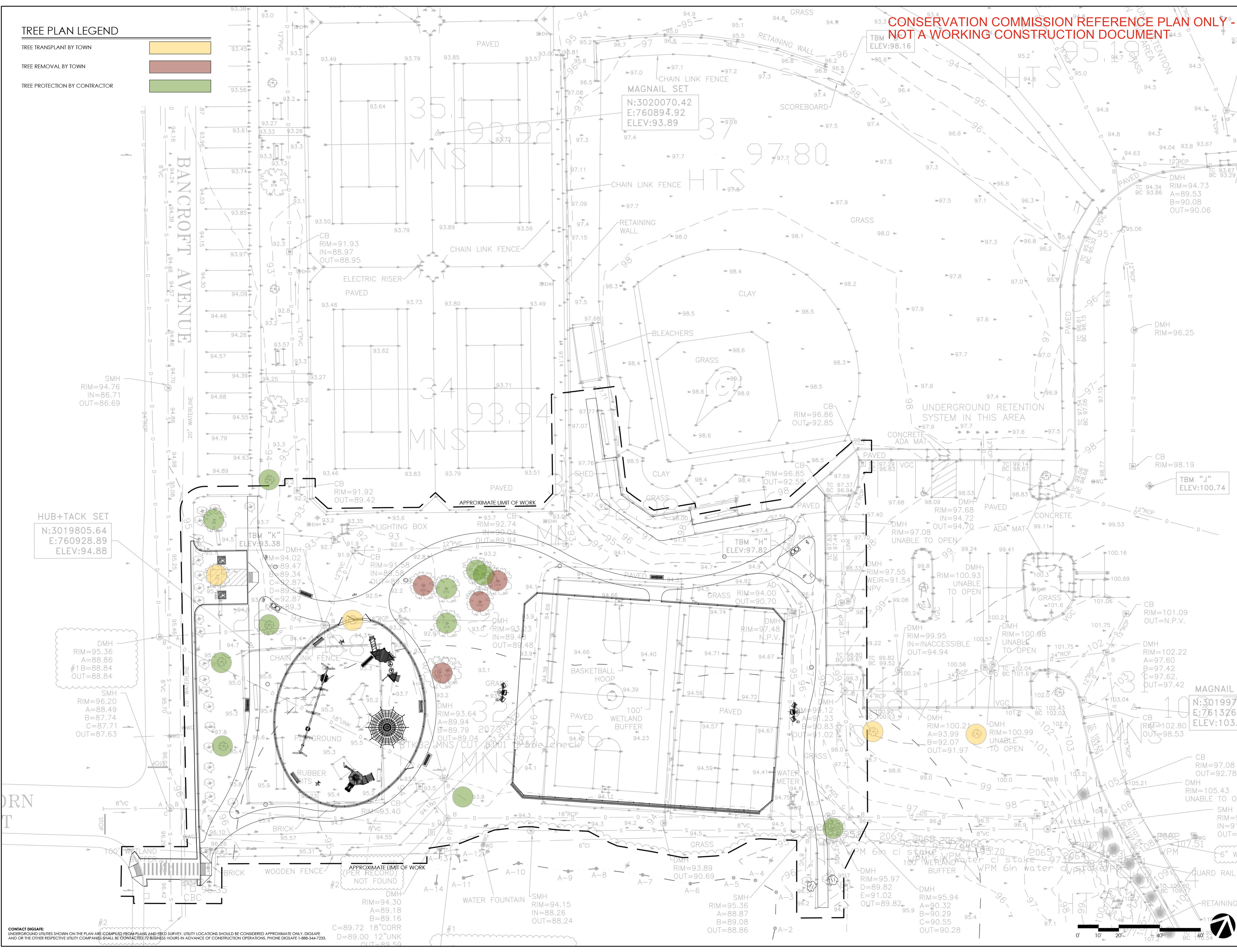

CONTACT DIGSAFE
 UNDERGROUND UTILITIES SHOWN ON THE PLAN ARE COMPILED FROM PLANS AND FIELD SURVEY. UTILITY LOCATIONS SHOULD BE CONSIDERED APPROXIMATE ONLY. DIGSAFE
 AND/OR THE OTHER RESPECTIVE UTILITY COMPANIES SHALL BE CONTACTED 72 BUSINESS HOURS IN ADVANCE OF CONSTRUCTION OPERATIONS. PHONE DIGSAFE 1-888-344-7233.

HANCOCK ASSOCIATES

Surveyors | Engineers | Scientists

April 16, 2025

Reading Conservation Commission
16 Lowell Street
Reading, MA 01876
Attn: Charles Tirone, Conservation Administrator

Subject: Drainage Memorandum
 Reading High School Modular Classroom Relocation

Hancock Associates has completed the design of a pad area and utility connections for the relocation of a modular classroom and associated minor site grading and pedestrian accommodation. The area for the classroom is located in a grass area adjacent to a small parking lot directly west of the main school building.

We have reviewed the stormwater associated with the roof drains of the modular building. The plan is to direct roof drain downspouts to a stone pad underneath the raised modular building. The Massachusetts Stormwater Handbook Standard 2 states that stormwater management systems shall be designed so that post-development peak discharge rates do not exceed pre-development peak discharge rates. The Town of Reading has indicated that proposed rates of runoff should not exceed existing rates for storm events up to and including the 10-year storm. The proposed condition discharge rates of runoff are at or below the existing rates to the same discharge point. Please see the attached HydroCAD output for more information. For the purpose of these calculations the following assumptions were made:

- The same total watershed area of the drainage areas is used to compare the existing and proposed.
- The Natural Resources Conservation Service (NRCS) Web Soil Survey of Middlesex County defines soils in the project area as:
 - 305B, Paxton fine sandy loam, 3 to 8 percent slopes, Hydrologic Soil Group C
 - 626B, Merrimac-Urban land complex, 3 to 15 percent slopes, Hydrologic Soil Group A
- The site has been split into Hydrologic Soil Group A and Hydrologic Soil Group C based on NRCS mapping. For calculation purposes hydrologic soil group C was modeled for the project area.

HANCOCK ASSOCIATES

Surveyors | Engineers | Scientists

The following table compares the peak rates of runoff under the existing and proposed conditions using the latest Atlas-14 Precipitation Data:

Table 1: Peak Rates of Runoff

Discharge Point	Peak Rate (cfs)					
	2-Year Storm (3.16" Rainfall Depth)		10-Year Storm (4.77" Rainfall Depth)		100-Year Storm (8.62" Rainfall Depth)	
	Existing	Proposed	Existing	Proposed	Existing	Proposed
DP	0.07	0.02	0.16	0.03	0.39	0.06

cfs – Cubic Feet per Second

The Massachusetts Stormwater Handbook Standard 3 states that loss of annual recharge to groundwater shall be eliminated or minimized. The annual recharge from the post-development site shall approximate the annual recharge from the pre-development conditions based on soil type. Recharge volumes are provided for the proposed impervious areas. For the purpose of these calculations, all of the development areas are considered to be Hydrologic Soil Group C. The required recharge volume is 0.25" multiplied by the area of impervious surfaces. Please see the attached HydroCAD summaries for the recharge volumes. The volume is as follows:

$$\begin{aligned} \text{Required Recharge Volume, HSG A} &= \text{Target Depth} * \text{Impervious Area} \\ &= 0.25'' * 2,417 \text{ SF} = 51 \text{ CF} \end{aligned}$$

While stormwater from the majority of the development will drain to the storage volume, some paved areas will drain to the discharge point. Since not all of the impervious areas will be drained to the provided recharge volume a capture area adjustment is applied to the required volume. The calculation is as follows:

$$\begin{aligned} \text{Capture Area Adjustment Factor} &= \text{Total Impervious Area} / \text{Impervious Area Draining to Recharge Volume} \\ &= 2,417 \text{ SF} / 2,096 \text{ SF} = 1.2 \end{aligned}$$

$$\begin{aligned} \text{Adjusted Required Recharge Volume} &= \text{Required Recharge Volume} * \text{Impervious Area Draining to Recharge Volume} \\ &= 51 \text{ CF} * 1.2 = 61 \text{ CF} \end{aligned}$$

HANCOCK ASSOCIATES

Surveyors | Engineers | Scientists

The recharge volume is provided below the lowest outlet within the infiltration system. The total volume provided is 907 cubic feet. See attached HydroCAD output for more details on volume storage. Since the volume provided is greater than the required recharge volume, the standard is met.

The Massachusetts Stormwater Handbook states that the recharge volume must drain within 72 hours. For calculation purposes the stormwater design was based on the more conservative hydrologic soil C at a Rawl's Rate of 0.17 inches per hour per the Massachusetts Stormwater Handbook.

$$\begin{aligned} \text{Drawdown Time} &= \text{Storage Volume} / (\text{Rawl's Rate} * \text{Bottom Area}) \\ &= 907 \text{ CF} / (0.17 \text{ in/hr} * 2, 267 \text{ SF}) = 28.2 \text{ Hours} \end{aligned}$$

Since the drawdown time is less than 72 hours, the requirement is met.

Given the temporary nature of the project and that we are only dealing with clean roof drainage, we feel the project fully complies with the Massachusetts DEP Stormwater Requirements.

Sincerely,
Hancock Associates

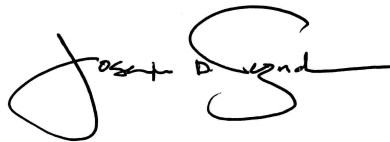

Joseph D. Peznola, P.E.

cc: Gienapp Architects

Hydrologic Soil Group—Middlesex County, Massachusetts



Soil Map may not be valid at this scale.

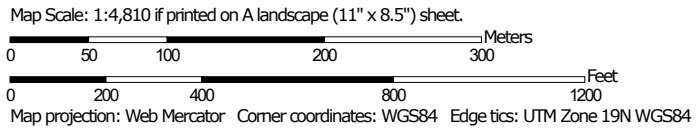

MAP LEGEND

Area of Interest (AOI)









 Area of Interest (AOI)

Soils

Soil Rating Polygons





 A
 A/D
 B
 B/D
 C
 C/D
 D
 Not rated or not available

Soil Rating Lines

 A
 A/D
 B
 B/D
 C
 C/D
 D
 Not rated or not available

Soil Rating Points





 A
 A/D
 B
 B/D

 C
 C/D
 D
 Not rated or not available

Water Features

 Streams and Canals

Transportation

 Rails
 Interstate Highways
 US Routes
 Major Roads
 Local Roads

Background

 Aerial Photography

MAP INFORMATION

The soil surveys that comprise your AOI were mapped at 1:24,000.

Warning: Soil Map may not be valid at this scale.

Enlargement of maps beyond the scale of mapping can cause misunderstanding of the detail of mapping and accuracy of soil line placement. The maps do not show the small areas of contrasting soils that could have been shown at a more detailed scale.

Please rely on the bar scale on each map sheet for map measurements.

Source of Map: Natural Resources Conservation Service
 Web Soil Survey URL:
 Coordinate System: Web Mercator (EPSG:3857)

Maps from the Web Soil Survey are based on the Web Mercator projection, which preserves direction and shape but distorts distance and area. A projection that preserves area, such as the Albers equal-area conic projection, should be used if more accurate calculations of distance or area are required.

This product is generated from the USDA-NRCS certified data as of the version date(s) listed below.

Soil Survey Area: Middlesex County, Massachusetts
 Survey Area Data: Version 24, Aug 27, 2024

Soil map units are labeled (as space allows) for map scales 1:50,000 or larger.

Date(s) aerial images were photographed: Mar 1, 2023—Sep 1, 2023

The orthophoto or other base map on which the soil lines were compiled and digitized probably differs from the background imagery displayed on these maps. As a result, some minor shifting of map unit boundaries may be evident.

Hydrologic Soil Group

Map unit symbol	Map unit name	Rating	Acres in AOI	Percent of AOI
6A	Scarboro mucky fine sandy loam, 0 to 3 percent slopes	A/D	0.0	0.0%
51A	Swansea muck, 0 to 1 percent slopes	B/D	2.7	2.7%
103B	Charlton-Hollis-Rock outcrop complex, 3 to 8 percent slopes	A	2.4	2.4%
104C	Hollis-Rock outcrop-Charlton complex, 0 to 15 percent slopes	D	6.6	6.6%
305B	Paxton fine sandy loam, 3 to 8 percent slopes	C	5.2	5.2%
305C	Paxton fine sandy loam, 8 to 15 percent slopes	C	0.7	0.7%
420B	Canton fine sandy loam, 3 to 8 percent slopes	B	0.9	0.9%
420C	Canton fine sandy loam, 8 to 15 percent slopes	B	2.1	2.1%
602	Urban land		17.5	17.5%
626B	Merrimac-Urban land complex, 0 to 8 percent slopes	A	17.8	17.8%
629C	Canton-Charlton-Urban land complex, 3 to 15 percent slopes	A	11.8	11.8%
631C	Charlton-Urban land-Hollis complex, 3 to 15 percent slopes, rocky	A	0.3	0.3%
655	Udorthents, wet substratum		32.1	32.1%
Totals for Area of Interest			100.0	100.0%

Description

Hydrologic soil groups are based on estimates of runoff potential. Soils are assigned to one of four groups according to the rate of water infiltration when the soils are not protected by vegetation, are thoroughly wet, and receive precipitation from long-duration storms.

The soils in the United States are assigned to four groups (A, B, C, and D) and three dual classes (A/D, B/D, and C/D). The groups are defined as follows:

Group A. Soils having a high infiltration rate (low runoff potential) when thoroughly wet. These consist mainly of deep, well drained to excessively drained sands or gravelly sands. These soils have a high rate of water transmission.

Group B. Soils having a moderate infiltration rate when thoroughly wet. These consist chiefly of moderately deep or deep, moderately well drained or well drained soils that have moderately fine texture to moderately coarse texture. These soils have a moderate rate of water transmission.

Group C. Soils having a slow infiltration rate when thoroughly wet. These consist chiefly of soils having a layer that impedes the downward movement of water or soils of moderately fine texture or fine texture. These soils have a slow rate of water transmission.

Group D. Soils having a very slow infiltration rate (high runoff potential) when thoroughly wet. These consist chiefly of clays that have a high shrink-swell potential, soils that have a high water table, soils that have a claypan or clay layer at or near the surface, and soils that are shallow over nearly impervious material. These soils have a very slow rate of water transmission.

If a soil is assigned to a dual hydrologic group (A/D, B/D, or C/D), the first letter is for drained areas and the second is for undrained areas. Only the soils that in their natural condition are in group D are assigned to dual classes.

Rating Options

Aggregation Method: Dominant Condition

Component Percent Cutoff: None Specified

Tie-break Rule: Higher

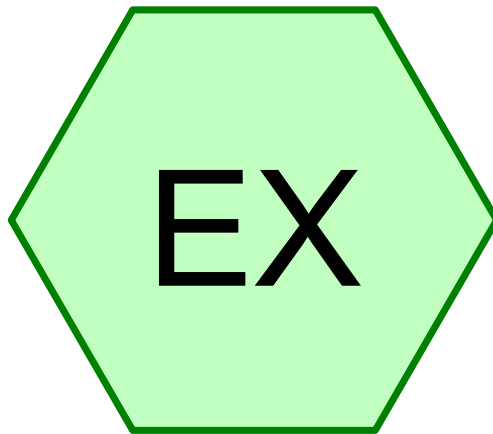

Pre-Modular Relocation

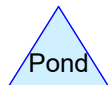
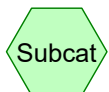

Summary for Subcatchment EX: Pre-Modular Relocation

[49] Hint: Tc<2dt may require smaller dt

Runoff = 0.07 cfs @ 12.09 hrs, Volume= 0.005 af, Depth> 1.01"

Runoff by SCS TR-20 method, UH=SCS, Weighted-CN, Time Span= 0.00-24.00 hrs, dt= 0.05 hrs
Type III 24-hr 2-Year Rainfall=3.16"

Area (sf)	CN	Description
2,654	74	>75% Grass cover, Good, HSG C
2,654		100.00% Pervious Area

Tc (min)	Length (feet)	Slope (ft/ft)	Velocity (ft/sec)	Capacity (cfs)	Description
5.0					Direct Entry,

Summary for Subcatchment EX: Pre-Modular Relocation

[49] Hint: Tc<2dt may require smaller dt

Runoff = 0.16 cfs @ 12.08 hrs, Volume= 0.011 af, Depth> 2.18"

Runoff by SCS TR-20 method, UH=SCS, Weighted-CN, Time Span= 0.00-24.00 hrs, dt= 0.05 hrs
Type III 24-hr 10-Year Rainfall=4.77"

Area (sf)	CN	Description
2,654	74	>75% Grass cover, Good, HSG C
2,654		100.00% Pervious Area

Tc (min)	Length (feet)	Slope (ft/ft)	Velocity (ft/sec)	Capacity (cfs)	Description
5.0					Direct Entry,

Summary for Subcatchment EX: Pre-Modular Relocation

[49] Hint: Tc<2dt may require smaller dt

Runoff = 0.39 cfs @ 12.08 hrs, Volume= 0.028 af, Depth> 5.48"

Runoff by SCS TR-20 method, UH=SCS, Weighted-CN, Time Span= 0.00-24.00 hrs, dt= 0.05 hrs
Type III 24-hr 100-Year Rainfall=8.62"

Area (sf)	CN	Description
2,654	74	>75% Grass cover, Good, HSG C
2,654		100.00% Pervious Area

Tc (min)	Length (feet)	Slope (ft/ft)	Velocity (ft/sec)	Capacity (cfs)	Description
5.0					Direct Entry,

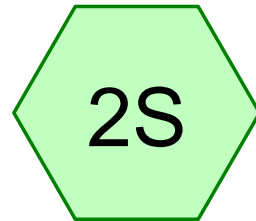
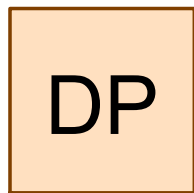
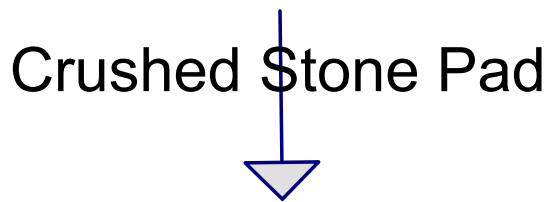
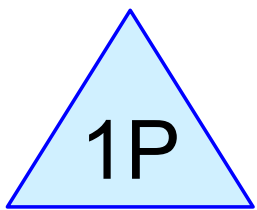
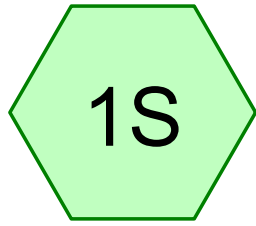

Post-Modular Relocation

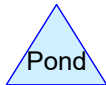
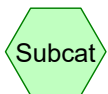

Summary for Subcatchment 1S:

Runoff = 0.16 cfs @ 12.07 hrs, Volume= 0.012 af, Depth> 2.71"
 Routed to Pond 1P : Crushed Stone Pad

Runoff by SCS TR-20 method, UH=SCS, Weighted-CN, Time Span= 0.00-24.00 hrs, dt= 0.05 hrs
 Type III 24-hr 2-Year Rainfall=3.16"

Area (sf)	CN	Description
2,096	98	Roofs, HSG C
237	74	>75% Grass cover, Good, HSG C
2,333	96	Weighted Average
237		10.16% Pervious Area
2,096		89.84% Impervious Area

Tc (min)	Length (feet)	Slope (ft/ft)	Velocity (ft/sec)	Capacity (cfs)	Description
5.0					Direct Entry,

Summary for Subcatchment 2S:

Runoff = 0.02 cfs @ 12.07 hrs, Volume= 0.002 af, Depth> 2.93"
 Routed to Reach DP : Post-Modular Relocation

Runoff by SCS TR-20 method, UH=SCS, Weighted-CN, Time Span= 0.00-24.00 hrs, dt= 0.05 hrs
 Type III 24-hr 2-Year Rainfall=3.16"

Area (sf)	CN	Description
321	98	Unconnected pavement, HSG C
321		100.00% Impervious Area
321		100.00% Unconnected

Tc (min)	Length (feet)	Slope (ft/ft)	Velocity (ft/sec)	Capacity (cfs)	Description
5.0					Direct Entry,

Summary for Reach DP: Post-Modular Relocation

Inflow Area = 0.061 ac, 91.07% Impervious, Inflow Depth > 0.35" for 2-Year event
 Inflow = 0.02 cfs @ 12.07 hrs, Volume= 0.002 af
 Outflow = 0.02 cfs @ 12.07 hrs, Volume= 0.002 af, Atten= 0%, Lag= 0.0 min

Routing by Stor-Ind+Trans method, Time Span= 0.00-24.00 hrs, dt= 0.05 hrs

Summary for Pond 1P: Crushed Stone Pad

Inflow Area = 0.054 ac, 89.84% Impervious, Inflow Depth > 2.71" for 2-Year event
 Inflow = 0.16 cfs @ 12.07 hrs, Volume= 0.012 af
 Outflow = 0.01 cfs @ 10.95 hrs, Volume= 0.011 af, Atten= 94%, Lag= 0.0 min
 Discarded = 0.01 cfs @ 10.95 hrs, Volume= 0.011 af
 Primary = 0.00 cfs @ 0.00 hrs, Volume= 0.000 af
 Routed to Reach DP : Post-Modular Relocation

Routing by Stor-Ind method, Time Span= 0.00-24.00 hrs, dt= 0.05 hrs / 2
 Peak Elev= 100.26' @ 13.89 hrs Surf.Area= 2,267 sf Storage= 240 cf

Plug-Flow detention time= 235.8 min calculated for 0.011 af (93% of inflow)
 Center-of-Mass det. time= 200.7 min (973.9 - 773.1)

Volume	Invert	Avail.Storage	Storage Description
#1	100.00'	907 cf	Custom Stage Data (Prismatic) Listed below (Recalc) 2,267 cf Overall x 40.0% Voids

Elevation (feet)	Surf.Area (sq-ft)	Inc.Store (cubic-feet)	Cum.Store (cubic-feet)
100.00	2,267	0	0
101.00	2,267	2,267	2,267

Device	Routing	Invert	Outlet Devices
#1	Primary	100.99'	80.5' long x 2.0' breadth Broad-Crested Rectangular Weir Head (feet) 0.20 0.40 0.60 0.80 1.00 1.20 1.40 1.60 1.80 2.00 2.50 3.00 3.50 Coef. (English) 2.54 2.61 2.61 2.60 2.66 2.70 2.77 2.89 2.88 2.85 3.07 3.20 3.32
#2	Discarded	100.00'	0.170 in/hr Exfiltration over Surface area

Discarded OutFlow Max=0.01 cfs @ 10.95 hrs HW=100.01' (Free Discharge)
 ↳2=Exfiltration (Exfiltration Controls 0.01 cfs)

Primary OutFlow Max=0.00 cfs @ 0.00 hrs HW=100.00' (Free Discharge)
 ↳1=Broad-Crested Rectangular Weir (Controls 0.00 cfs)

28302

Type III 24-hr 10-Year Rainfall=4.77"

Prepared by Hancock Associates

Printed 4/15/2025

HydroCAD® 10.20-3h s/n 00711 © 2024 HydroCAD Software Solutions LLC

Page 1

Time span=0.00-24.00 hrs, dt=0.05 hrs, 481 points
Runoff by SCS TR-20 method, UH=SCS, Weighted-CN
Reach routing by Stor-Ind+Trans method - Pond routing by Stor-Ind method

Subcatchment 1S: Runoff Area=2,333 sf 89.84% Impervious Runoff Depth>4.30"
Tc=5.0 min CN=96 Runoff=0.25 cfs 0.019 af

Subcatchment 2S: Runoff Area=321 sf 100.00% Impervious Runoff Depth>4.53"
Tc=5.0 min CN=98 Runoff=0.03 cfs 0.003 af

Reach DP: Post-Modular Relocation Inflow=0.03 cfs 0.003 af
Outflow=0.03 cfs 0.003 af

Pond 1P: Crushed Stone Pad Peak Elev=100.49' Storage=448 cf Inflow=0.25 cfs 0.019 af
Discarded=0.01 cfs 0.012 af Primary=0.00 cfs 0.000 af Outflow=0.01 cfs 0.012 af

Summary for Pond 1P: Crushed Stone Pad

Inflow Area = 0.054 ac, 89.84% Impervious, Inflow Depth > 4.30" for 10-Year event
 Inflow = 0.25 cfs @ 12.07 hrs, Volume= 0.019 af
 Outflow = 0.01 cfs @ 9.65 hrs, Volume= 0.012 af, Atten= 96%, Lag= 0.0 min
 Discarded = 0.01 cfs @ 9.65 hrs, Volume= 0.012 af
 Primary = 0.00 cfs @ 0.00 hrs, Volume= 0.000 af
 Routed to Reach DP : Post-Modular Relocation

Routing by Stor-Ind method, Time Span= 0.00-24.00 hrs, dt= 0.05 hrs / 2
 Peak Elev= 100.49' @ 15.30 hrs Surf.Area= 2,267 sf Storage= 448 cf

Plug-Flow detention time= 264.0 min calculated for 0.012 af (65% of inflow)
 Center-of-Mass det. time= 165.2 min (927.5 - 762.3)

Volume	Invert	Avail.Storage	Storage Description
#1	100.00'	907 cf	Custom Stage Data (Prismatic) Listed below (Recalc) 2,267 cf Overall x 40.0% Voids

Elevation (feet)	Surf.Area (sq-ft)	Inc.Store (cubic-feet)	Cum.Store (cubic-feet)
100.00	2,267	0	0
101.00	2,267	2,267	2,267

Device	Routing	Invert	Outlet Devices
#1	Primary	100.99'	80.5' long x 2.0' breadth Broad-Crested Rectangular Weir Head (feet) 0.20 0.40 0.60 0.80 1.00 1.20 1.40 1.60 1.80 2.00 2.50 3.00 3.50 Coef. (English) 2.54 2.61 2.61 2.60 2.66 2.70 2.77 2.89 2.88 2.85 3.07 3.20 3.32
#2	Discarded	100.00'	0.170 in/hr Exfiltration over Surface area

Discarded OutFlow Max=0.01 cfs @ 9.65 hrs HW=100.01' (Free Discharge)
 ↳ **2=Exfiltration** (Exfiltration Controls 0.01 cfs)

Primary OutFlow Max=0.00 cfs @ 0.00 hrs HW=100.00' (Free Discharge)
 ↳ **1=Broad-Crested Rectangular Weir** (Controls 0.00 cfs)

28302

Type III 24-hr 100-Year Rainfall=8.62"

Prepared by Hancock Associates

Printed 4/15/2025

HydroCAD® 10.20-3h s/n 00711 © 2024 HydroCAD Software Solutions LLC

Page 2

Time span=0.00-24.00 hrs, dt=0.05 hrs, 481 points
Runoff by SCS TR-20 method, UH=SCS, Weighted-CN
Reach routing by Stor-Ind+Trans method - Pond routing by Stor-Ind method

Subcatchment 1S: Runoff Area=2,333 sf 89.84% Impervious Runoff Depth>8.14"
Tc=5.0 min CN=96 Runoff=0.45 cfs 0.036 af

Subcatchment 2S: Runoff Area=321 sf 100.00% Impervious Runoff Depth>8.38"
Tc=5.0 min CN=98 Runoff=0.06 cfs 0.005 af

Reach DP: Post-Modular Relocation Inflow=0.06 cfs 0.008 af
Outflow=0.06 cfs 0.008 af

Pond 1P: Crushed Stone Pad Peak Elev=100.99' Storage=899 cf Inflow=0.45 cfs 0.036 af
Discarded=0.01 cfs 0.014 af Primary=0.02 cfs 0.003 af Outflow=0.03 cfs 0.017 af

Summary for Pond 1P: Crushed Stone Pad

Inflow Area = 0.054 ac, 89.84% Impervious, Inflow Depth > 8.14" for 100-Year event
 Inflow = 0.45 cfs @ 12.07 hrs, Volume= 0.036 af
 Outflow = 0.03 cfs @ 13.15 hrs, Volume= 0.017 af, Atten= 93%, Lag= 64.8 min
 Discarded = 0.01 cfs @ 7.60 hrs, Volume= 0.014 af
 Primary = 0.02 cfs @ 13.15 hrs, Volume= 0.003 af
 Routed to Reach DP : Post-Modular Relocation

Routing by Stor-Ind method, Time Span= 0.00-24.00 hrs, dt= 0.05 hrs / 2
 Peak Elev= 100.99' @ 13.15 hrs Surf.Area= 2,267 sf Storage= 899 cf

Plug-Flow detention time= 239.3 min calculated for 0.017 af (48% of inflow)
 Center-of-Mass det. time= 107.0 min (856.7 - 749.7)

Volume	Invert	Avail.Storage	Storage Description
#1	100.00'	907 cf	Custom Stage Data (Prismatic) Listed below (Recalc) 2,267 cf Overall x 40.0% Voids

Elevation (feet)	Surf.Area (sq-ft)	Inc.Store (cubic-feet)	Cum.Store (cubic-feet)
100.00	2,267	0	0
101.00	2,267	2,267	2,267

Device	Routing	Invert	Outlet Devices
#1	Primary	100.99'	80.5' long x 2.0' breadth Broad-Crested Rectangular Weir Head (feet) 0.20 0.40 0.60 0.80 1.00 1.20 1.40 1.60 1.80 2.00 2.50 3.00 3.50 Coef. (English) 2.54 2.61 2.61 2.60 2.66 2.70 2.77 2.89 2.88 2.85 3.07 3.20 3.32
#2	Discarded	100.00'	0.170 in/hr Exfiltration over Surface area

Discarded OutFlow Max=0.01 cfs @ 7.60 hrs HW=100.01' (Free Discharge)
 ↳ **2=Exfiltration** (Exfiltration Controls 0.01 cfs)

Primary OutFlow Max=0.01 cfs @ 13.15 hrs HW=100.99' (Free Discharge)
 ↳ **1=Broad-Crested Rectangular Weir** (Weir Controls 0.01 cfs @ 0.09 fps)

28302

Type III 24-hr 100-Year Rainfall=8.62"

Prepared by Hancock Associates

Printed 4/15/2025

HydroCAD® 10.20-3h s/n 00711 © 2024 HydroCAD Software Solutions LLC

Stage-Area-Storage for Pond 1P: Crushed Stone Pad

Elevation (feet)	Surface (sq-ft)	Storage (cubic-feet)	Elevation (feet)	Surface (sq-ft)	Storage (cubic-feet)
100.00	2,267	0	100.53	2,267	481
100.01	2,267	9	100.54	2,267	490
100.02	2,267	18	100.55	2,267	499
100.03	2,267	27	100.56	2,267	508
100.04	2,267	36	100.57	2,267	517
100.05	2,267	45	100.58	2,267	526
100.06	2,267	54	100.59	2,267	535
100.07	2,267	63	100.60	2,267	544
100.08	2,267	73	100.61	2,267	553
100.09	2,267	82	100.62	2,267	562
100.10	2,267	91	100.63	2,267	571
100.11	2,267	100	100.64	2,267	580
100.12	2,267	109	100.65	2,267	589
100.13	2,267	118	100.66	2,267	598
100.14	2,267	127	100.67	2,267	608
100.15	2,267	136	100.68	2,267	617
100.16	2,267	145	100.69	2,267	626
100.17	2,267	154	100.70	2,267	635
100.18	2,267	163	100.71	2,267	644
100.19	2,267	172	100.72	2,267	653
100.20	2,267	181	100.73	2,267	662
100.21	2,267	190	100.74	2,267	671
100.22	2,267	199	100.75	2,267	680
100.23	2,267	209	100.76	2,267	689
100.24	2,267	218	100.77	2,267	698
100.25	2,267	227	100.78	2,267	707
100.26	2,267	236	100.79	2,267	716
100.27	2,267	245	100.80	2,267	725
100.28	2,267	254	100.81	2,267	735
100.29	2,267	263	100.82	2,267	744
100.30	2,267	272	100.83	2,267	753
100.31	2,267	281	100.84	2,267	762
100.32	2,267	290	100.85	2,267	771
100.33	2,267	299	100.86	2,267	780
100.34	2,267	308	100.87	2,267	789
100.35	2,267	317	100.88	2,267	798
100.36	2,267	326	100.89	2,267	807
100.37	2,267	336	100.90	2,267	816
100.38	2,267	345	100.91	2,267	825
100.39	2,267	354	100.92	2,267	834
100.40	2,267	363	100.93	2,267	843
100.41	2,267	372	100.94	2,267	852
100.42	2,267	381	100.95	2,267	861
100.43	2,267	390	100.96	2,267	871
100.44	2,267	399	100.97	2,267	880
100.45	2,267	408	100.98	2,267	889
100.46	2,267	417	100.99	2,267	898
100.47	2,267	426	101.00	2,267	907
100.48	2,267	435			
100.49	2,267	444			
100.50	2,267	453			
100.51	2,267	462			
100.52	2,267	472			





Checklist for Stormwater Report

A. Introduction

Important: When filling out forms on the computer, use only the tab key to move your cursor - do not use the return key.



A Stormwater Report must be submitted with the Notice of Intent permit application to document compliance with the Stormwater Management Standards. The following checklist is NOT a substitute for the Stormwater Report (which should provide more substantive and detailed information) but is offered here as a tool to help the applicant organize their Stormwater Management documentation for their Report and for the reviewer to assess this information in a consistent format. As noted in the Checklist, the Stormwater Report must contain the engineering computations and supporting information set forth in Volume 3 of the [Massachusetts Stormwater Handbook](#). The Stormwater Report must be prepared and certified by a Registered Professional Engineer (RPE) licensed in the Commonwealth.

The Stormwater Report must include:

- The Stormwater Checklist completed and stamped by a Registered Professional Engineer (see page 2) that certifies that the Stormwater Report contains all required submittals.¹ This Checklist is to be used as the cover for the completed Stormwater Report.
- Applicant/Project Name
- Project Address
- Name of Firm and Registered Professional Engineer that prepared the Report
- Long-Term Pollution Prevention Plan required by Standards 4-6
- Construction Period Pollution Prevention and Erosion and Sedimentation Control Plan required by Standard 8²
- Operation and Maintenance Plan required by Standard 9

In addition to all plans and supporting information, the Stormwater Report must include a brief narrative describing stormwater management practices, including environmentally sensitive site design and LID techniques, along with a diagram depicting runoff through the proposed BMP treatment train. Plans are required to show existing and proposed conditions, identify all wetland resource areas, NRCS soil types, critical areas, Land Uses with Higher Potential Pollutant Loads (LUHPPL), and any areas on the site where infiltration rate is greater than 2.4 inches per hour. The Plans shall identify the drainage areas for both existing and proposed conditions at a scale that enables verification of supporting calculations.

As noted in the Checklist, the Stormwater Management Report shall document compliance with each of the Stormwater Management Standards as provided in the Massachusetts Stormwater Handbook. The soils evaluation and calculations shall be done using the methodologies set forth in Volume 3 of the Massachusetts Stormwater Handbook.

To ensure that the Stormwater Report is complete, applicants are required to fill in the Stormwater Report Checklist by checking the box to indicate that the specified information has been included in the Stormwater Report. If any of the information specified in the checklist has not been submitted, the applicant must provide an explanation. The completed Stormwater Report Checklist and Certification must be submitted with the Stormwater Report.

¹ The Stormwater Report may also include the Illicit Discharge Compliance Statement required by Standard 10. If not included in the Stormwater Report, the Illicit Discharge Compliance Statement must be submitted prior to the discharge of stormwater runoff to the post-construction best management practices.

² For some complex projects, it may not be possible to include the Construction Period Erosion and Sedimentation Control Plan in the Stormwater Report. In that event, the issuing authority has the discretion to issue an Order of Conditions that approves the project and includes a condition requiring the proponent to submit the Construction Period Erosion and Sedimentation Control Plan before commencing any land disturbance activity on the site.



Checklist for Stormwater Report

B. Stormwater Checklist and Certification

The following checklist is intended to serve as a guide for applicants as to the elements that ordinarily need to be addressed in a complete Stormwater Report. The checklist is also intended to provide conservation commissions and other reviewing authorities with a summary of the components necessary for a comprehensive Stormwater Report that addresses the ten Stormwater Standards.

Note: Because stormwater requirements vary from project to project, it is possible that a complete Stormwater Report may not include information on some of the subjects specified in the Checklist. If it is determined that a specific item does not apply to the project under review, please note that the item is not applicable (N.A.) and provide the reasons for that determination.

A complete checklist must include the Certification set forth below signed by the Registered Professional Engineer who prepared the Stormwater Report.

Registered Professional Engineer's Certification

I have reviewed the Stormwater Report, including the soil evaluation, computations, Long-term Pollution Prevention Plan, the Construction Period Erosion and Sedimentation Control Plan (if included), the Long-term Post-Construction Operation and Maintenance Plan, the Illicit Discharge Compliance Statement (if included) and the plans showing the stormwater management system, and have determined that they have been prepared in accordance with the requirements of the Stormwater Management Standards as further elaborated by the Massachusetts Stormwater Handbook. I have also determined that the information presented in the Stormwater Checklist is accurate and that the information presented in the Stormwater Report accurately reflects conditions at the site as of the date of this permit application.

Registered Professional Engineer Block and Signature

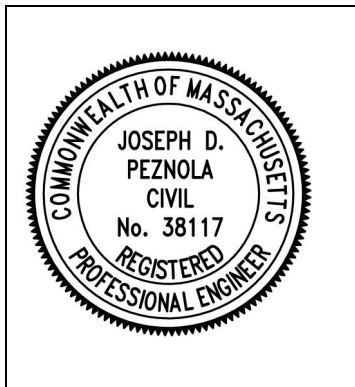

4-16-25

Signature and Date

Checklist

Project Type: Is the application for new development, redevelopment, or a mix of new and redevelopment?

- New development
- Redevelopment
- Mix of New Development and Redevelopment



Checklist for Stormwater Report

Checklist (continued)

LID Measures: Stormwater Standards require LID measures to be considered. Document what environmentally sensitive design and LID Techniques were considered during the planning and design of the project:

- No disturbance to any Wetland Resource Areas
- Site Design Practices (e.g. clustered development, reduced frontage setbacks)
- Reduced Impervious Area (Redevelopment Only)
- Minimizing disturbance to existing trees and shrubs
- LID Site Design Credit Requested:
 - Credit 1
 - Credit 2
 - Credit 3
- Use of "country drainage" versus curb and gutter conveyance and pipe
- Bioretention Cells (includes Rain Gardens)
- Constructed Stormwater Wetlands (includes Gravel Wetlands designs)
- Treebox Filter
- Water Quality Swale
- Grass Channel
- Green Roof
- Other (describe): _____

Standard 1: No New Untreated Discharges

- No new untreated discharges
- Outlets have been designed so there is no erosion or scour to wetlands and waters of the Commonwealth
- Supporting calculations specified in Volume 3 of the Massachusetts Stormwater Handbook included.



Checklist for Stormwater Report

Checklist (continued)

Standard 2: Peak Rate Attenuation

- Standard 2 waiver requested because the project is located in land subject to coastal storm flowage and stormwater discharge is to a wetland subject to coastal flooding.
- Evaluation provided to determine whether off-site flooding increases during the 100-year 24-hour storm.
- Calculations provided to show that post-development peak discharge rates do not exceed pre-development rates for the 2-year and 10-year 24-hour storms. If evaluation shows that off-site flooding increases during the 100-year 24-hour storm, calculations are also provided to show that post-development peak discharge rates do not exceed pre-development rates for the 100-year 24-hour storm.

Standard 3: Recharge

- Soil Analysis provided.
- Required Recharge Volume calculation provided.
- Required Recharge volume reduced through use of the LID site Design Credits.
- Sizing the infiltration, BMPs is based on the following method: Check the method used.
 - Static
 - Simple Dynamic
 - Dynamic Field¹
- Runoff from all impervious areas at the site discharging to the infiltration BMP.
- Runoff from all impervious areas at the site is *not* discharging to the infiltration BMP and calculations are provided showing that the drainage area contributing runoff to the infiltration BMPs is sufficient to generate the required recharge volume.
- Recharge BMPs have been sized to infiltrate the Required Recharge Volume.
- Recharge BMPs have been sized to infiltrate the Required Recharge Volume *only* to the maximum extent practicable for the following reason:
 - Site is comprised solely of C and D soils and/or bedrock at the land surface
 - M.G.L. c. 21E sites pursuant to 310 CMR 40.0000
 - Solid Waste Landfill pursuant to 310 CMR 19.000
 - Project is otherwise subject to Stormwater Management Standards only to the maximum extent practicable.
- Calculations showing that the infiltration BMPs will drain in 72 hours are provided.
- Property includes a M.G.L. c. 21E site or a solid waste landfill and a mounding analysis is included.

¹ 80% TSS removal is required prior to discharge to infiltration BMP if Dynamic Field method is used.



Checklist for Stormwater Report

Checklist (continued)

Standard 3: Recharge (continued)

- The infiltration BMP is used to attenuate peak flows during storms greater than or equal to the 10-year 24-hour storm and separation to seasonal high groundwater is less than 4 feet and a mounding analysis is provided.
- Documentation is provided showing that infiltration BMPs do not adversely impact nearby wetland resource areas.

Standard 4: Water Quality

The Long-Term Pollution Prevention Plan typically includes the following:

- Good housekeeping practices;
 - Provisions for storing materials and waste products inside or under cover;
 - Vehicle washing controls;
 - Requirements for routine inspections and maintenance of stormwater BMPs;
 - Spill prevention and response plans;
 - Provisions for maintenance of lawns, gardens, and other landscaped areas;
 - Requirements for storage and use of fertilizers, herbicides, and pesticides;
 - Pet waste management provisions;
 - Provisions for operation and management of septic systems;
 - Provisions for solid waste management;
 - Snow disposal and plowing plans relative to Wetland Resource Areas;
 - Winter Road Salt and/or Sand Use and Storage restrictions;
 - Street sweeping schedules;
 - Provisions for prevention of illicit discharges to the stormwater management system;
 - Documentation that Stormwater BMPs are designed to provide for shutdown and containment in the event of a spill or discharges to or near critical areas or from LUHPPL;
 - Training for staff or personnel involved with implementing Long-Term Pollution Prevention Plan;
 - List of Emergency contacts for implementing Long-Term Pollution Prevention Plan.
- A Long-Term Pollution Prevention Plan is attached to Stormwater Report and is included as an attachment to the Wetlands Notice of Intent.
 - Treatment BMPs subject to the 44% TSS removal pretreatment requirement and the one inch rule for calculating the water quality volume are included, and discharge:
 - is within the Zone II or Interim Wellhead Protection Area
 - is near or to other critical areas
 - is within soils with a rapid infiltration rate (greater than 2.4 inches per hour)
 - involves runoff from land uses with higher potential pollutant loads.
 - The Required Water Quality Volume is reduced through use of the LID site Design Credits.
 - Calculations documenting that the treatment train meets the 80% TSS removal requirement and, if applicable, the 44% TSS removal pretreatment requirement, are provided.



Checklist for Stormwater Report

Checklist (continued)

Standard 4: Water Quality (continued)

- The BMP is sized (and calculations provided) based on:
 - The ½" or 1" Water Quality Volume or
 - The equivalent flow rate associated with the Water Quality Volume and documentation is provided showing that the BMP treats the required water quality volume.
- The applicant proposes to use proprietary BMPs, and documentation supporting use of proprietary BMP and proposed TSS removal rate is provided. This documentation may be in the form of the proprietary BMP checklist found in Volume 2, Chapter 4 of the Massachusetts Stormwater Handbook and submitting copies of the TARP Report, STEP Report, and/or other third party studies verifying performance of the proprietary BMPs.
- A TMDL exists that indicates a need to reduce pollutants other than TSS and documentation showing that the BMPs selected are consistent with the TMDL is provided.

Standard 5: Land Uses With Higher Potential Pollutant Loads (LUHPPLs)

- The NPDES Multi-Sector General Permit covers the land use and the Stormwater Pollution Prevention Plan (SWPPP) has been included with the Stormwater Report.
- The NPDES Multi-Sector General Permit covers the land use and the SWPPP will be submitted **prior to** the discharge of stormwater to the post-construction stormwater BMPs.
- The NPDES Multi-Sector General Permit does **not** cover the land use.
- LUHPPLs are located at the site and industry specific source control and pollution prevention measures have been proposed to reduce or eliminate the exposure of LUHPPLs to rain, snow, snow melt and runoff, and been included in the long term Pollution Prevention Plan.
- All exposure has been eliminated.
- All exposure has **not** been eliminated and all BMPs selected are on MassDEP LUHPPL list.
- The LUHPPL has the potential to generate runoff with moderate to higher concentrations of oil and grease (e.g. all parking lots with >1000 vehicle trips per day) and the treatment train includes an oil grit separator, a filtering bioretention area, a sand filter or equivalent.

Standard 6: Critical Areas

- The discharge is near or to a critical area and the treatment train includes only BMPs that MassDEP has approved for stormwater discharges to or near that particular class of critical area.
- Critical areas and BMPs are identified in the Stormwater Report.



Checklist for Stormwater Report

Checklist (continued)

Standard 7: Redevelopments and Other Projects Subject to the Standards only to the maximum extent practicable

- The project is subject to the Stormwater Management Standards only to the maximum Extent Practicable as a:
 - Limited Project
 - Small Residential Projects: 5-9 single family houses or 5-9 units in a multi-family development provided there is no discharge that may potentially affect a critical area.
 - Small Residential Projects: 2-4 single family houses or 2-4 units in a multi-family development with a discharge to a critical area
 - Marina and/or boatyard provided the hull painting, service and maintenance areas are protected from exposure to rain, snow, snow melt and runoff
 - Bike Path and/or Foot Path
 - Redevelopment Project
 - Redevelopment portion of mix of new and redevelopment.
- Certain standards are not fully met (Standard No. 1, 8, 9, and 10 must always be fully met) and an explanation of why these standards are not met is contained in the Stormwater Report.
- The project involves redevelopment and a description of all measures that have been taken to improve existing conditions is provided in the Stormwater Report. The redevelopment checklist found in Volume 2 Chapter 3 of the Massachusetts Stormwater Handbook may be used to document that the proposed stormwater management system (a) complies with Standards 2, 3 and the pretreatment and structural BMP requirements of Standards 4-6 to the maximum extent practicable and (b) improves existing conditions.

Standard 8: Construction Period Pollution Prevention and Erosion and Sedimentation Control

A Construction Period Pollution Prevention and Erosion and Sedimentation Control Plan must include the following information:

- Narrative;
 - Construction Period Operation and Maintenance Plan;
 - Names of Persons or Entity Responsible for Plan Compliance;
 - Construction Period Pollution Prevention Measures;
 - Erosion and Sedimentation Control Plan Drawings;
 - Detail drawings and specifications for erosion control BMPs, including sizing calculations;
 - Vegetation Planning;
 - Site Development Plan;
 - Construction Sequencing Plan;
 - Sequencing of Erosion and Sedimentation Controls;
 - Operation and Maintenance of Erosion and Sedimentation Controls;
 - Inspection Schedule;
 - Maintenance Schedule;
 - Inspection and Maintenance Log Form.
- A Construction Period Pollution Prevention and Erosion and Sedimentation Control Plan containing the information set forth above has been included in the Stormwater Report.



Checklist for Stormwater Report

Checklist (continued)

Standard 8: Construction Period Pollution Prevention and Erosion and Sedimentation Control (continued)

- The project is highly complex and information is included in the Stormwater Report that explains why it is not possible to submit the Construction Period Pollution Prevention and Erosion and Sedimentation Control Plan with the application. A Construction Period Pollution Prevention and Erosion and Sedimentation Control has **not** been included in the Stormwater Report but will be submitted **before** land disturbance begins.
- The project is **not** covered by a NPDES Construction General Permit.
- The project is covered by a NPDES Construction General Permit and a copy of the SWPPP is in the Stormwater Report.
- The project is covered by a NPDES Construction General Permit but no SWPPP been submitted. The SWPPP will be submitted BEFORE land disturbance begins.

Standard 9: Operation and Maintenance Plan

- The Post Construction Operation and Maintenance Plan is included in the Stormwater Report and includes the following information:
 - Name of the stormwater management system owners;
 - Party responsible for operation and maintenance;
 - Schedule for implementation of routine and non-routine maintenance tasks;
 - Plan showing the location of all stormwater BMPs maintenance access areas;
 - Description and delineation of public safety features;
 - Estimated operation and maintenance budget; and
 - Operation and Maintenance Log Form.
- The responsible party is **not** the owner of the parcel where the BMP is located and the Stormwater Report includes the following submissions:
 - A copy of the legal instrument (deed, homeowner's association, utility trust or other legal entity) that establishes the terms of and legal responsibility for the operation and maintenance of the project site stormwater BMPs;
 - A plan and easement deed that allows site access for the legal entity to operate and maintain BMP functions.

Standard 10: Prohibition of Illicit Discharges

- The Long-Term Pollution Prevention Plan includes measures to prevent illicit discharges;
- An Illicit Discharge Compliance Statement is attached;
- NO Illicit Discharge Compliance Statement is attached but will be submitted **prior to** the discharge of any stormwater to post-construction BMPs.

PERMIT SITE PLAN

62 Oakland Street
Reading, Massachusetts 01867

ASSESSORS:

MAP 33 LOT 57

REFERENCES:

Deed Book 5476, Page 185

RECORD OWNER:

TOWN OF READING

PREPARED FOR:

Gienapp
Architects, LLC

20 Conant Street
Danvers, Massachusetts 01923

HANCOCK
ASSOCIATES

Civil Engineers

Land Surveyors

Wetland Scientists

185 CENTRE STREET, DANVERS, MA 01923
VOICE (978) 777-3050, FAX (978) 774-7816
WWW.HANCOCKASSOCIATES.COM

1.	BY	JTE	04/11/25	ADDENDUM #1
NO.	BY	APP	DATE	ISSUE/REVISION DESCRIPTION
DATE:	03/25/25	DESIGN BY:	JTE/JDP	
SCALE:	AS SHOWN	DRAWN BY:	JTE	
APPRVD. BY:	JDP	CHECK BY:	JJP	

DETAIL SHEET

PLT DATE: Apr 11, 2025, 12:18 pm
PART: P:\04 25 Project\02\0202_SitePlan.dwg - Reading\Eng\DWG

DWG: 28302_PSP_Bid.dwg

LAYOUT: DET

SHEET: 3 OF 3

PROJECT NO.:

28302

C3

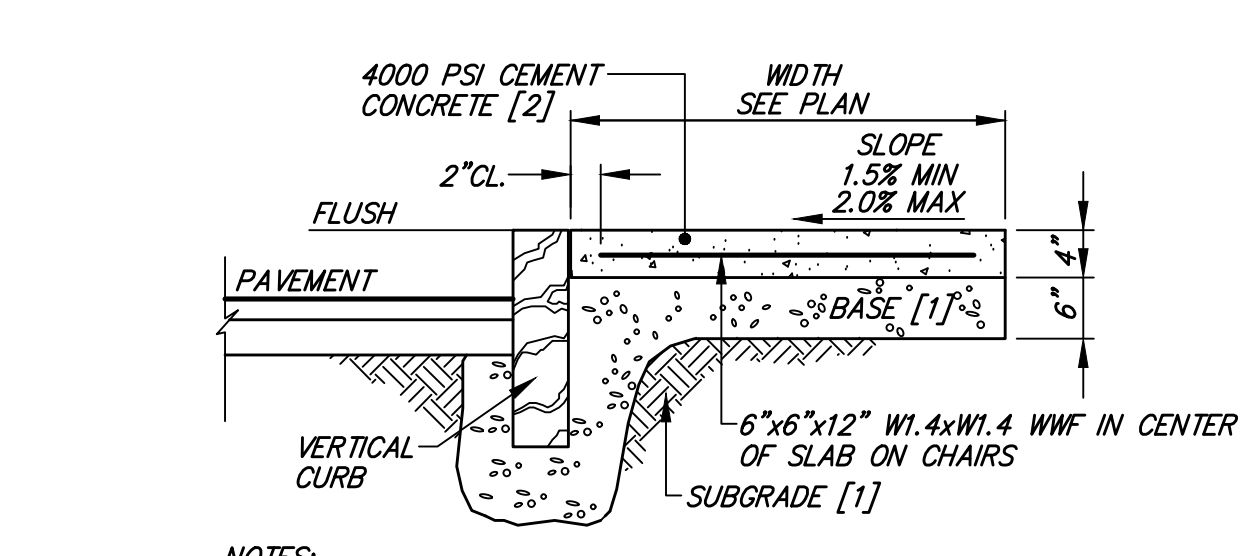
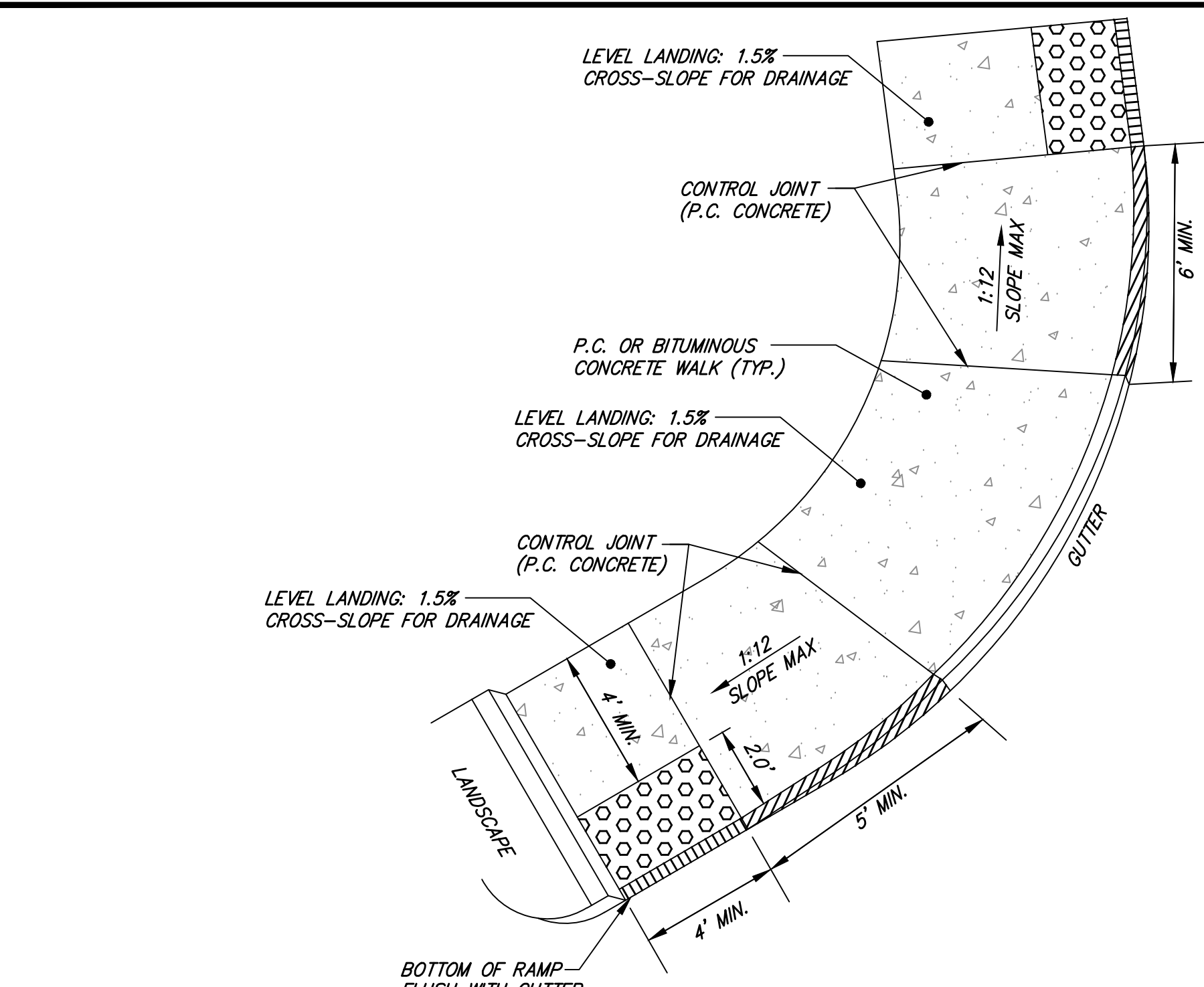

- NOTES:**
1. THE MAXIMUM ALLOWABLE SIDEWALK AND RAMP CROSS SLOPES SHALL BE 1.5 (1% MIN.).
 2. THE MAXIMUM ALLOWABLE SLOPE OF ACCESSIBLE ROUTE EXCLUDING CURB RAMPS SHALL BE 5%.
 3. THE MAXIMUM ALLOWABLE SLOPE OF ACCESSIBLE ROUTE CURB RAMPS SHALL BE 7.5%.
 4. A MINIMUM OF 3 FEET CLEAR SHALL BE MAINTAINED AT ANY PERMANENT OBSTACLE IN ACCESSIBLE ROUTE (I.E., HYDRANTS, UTILITY POLES, TREE WELLS, SIGNS, ETC.).
 5. CURB TREATMENT VARIES. SEE PLAN FOR CURB TYPE.
 6. RAMP, CURB AND ADJACENT PAVEMENTS SHALL BE GRADED TO PREVENT PONDING.
 7. SEE TYPICAL SIDEWALK SECTION FOR RAMP CONSTRUCTION.
 8. WHERE ACCESSIBLE ROUTES ARE LESS THAN 5' IN WIDTH (EXCLUDING CURBING) A 5x5' PASSING AREA SHALL BE PROVIDED AT INTERVALS NOT TO EXCEED 200 FEET.
 9. ELIMINATE CURBING AT RAMP WHERE IT ABUTS ROADWAY, EXCEPT WHERE VERTICAL CURBING IS INDICATED ON THE DRAWINGS TO BE INSTALLED AND SET FLUSH.

3 CEMENT CONCRETE SIDEWALK
CROSS SECTION
NOT TO SCALE

4 ACCESSIBLE PEDESTRIAN RAMP
CROSS SECTION
NOT TO SCALE

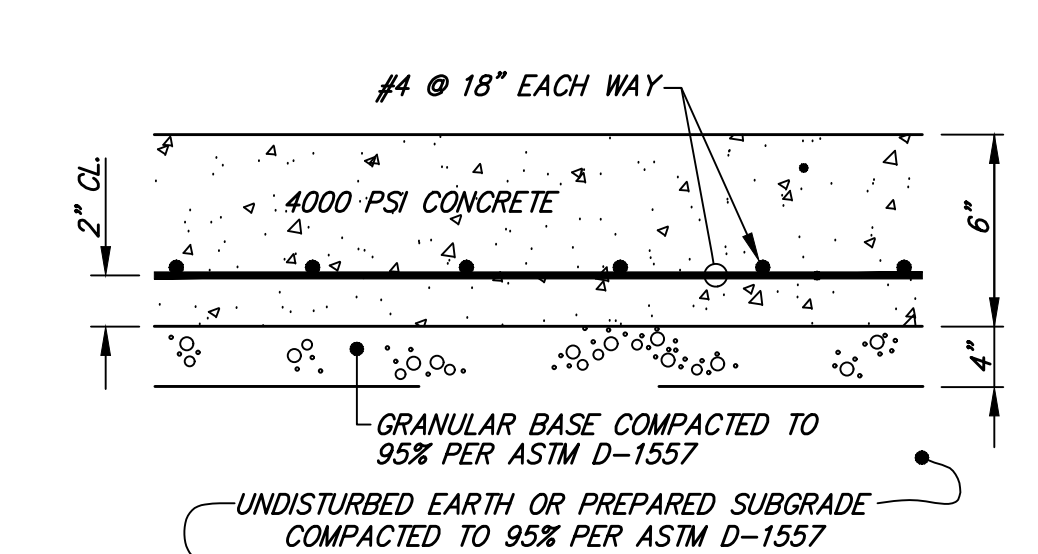

7 CONCRETE PAD
TYPICAL CROSS SECTION
NOT TO SCALE

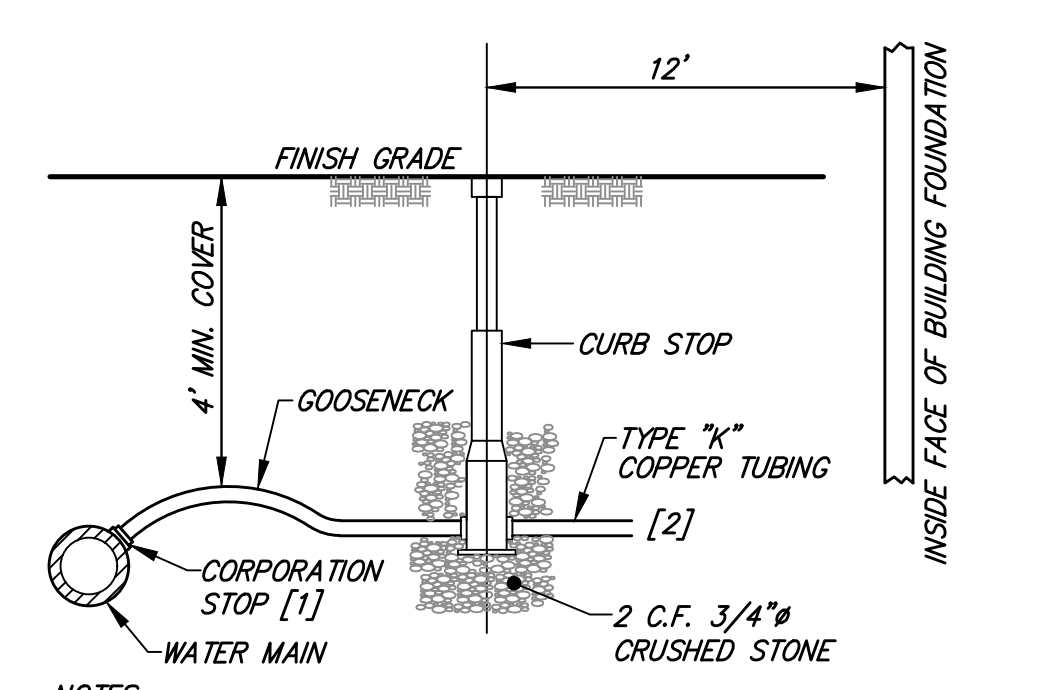

- NOTES:**
- [1] WATER SERVICES LARGER THAN ONE INCH ARE TO BE RESTRAINED TO MAIN WITH APPROVED SADDLE.
 - [2] COORDINATE BUILDING CONNECTION WITH PLUMBING DRAWINGS.

8 WATER SERVICE
TYPICAL PROFILE
NOT TO SCALE

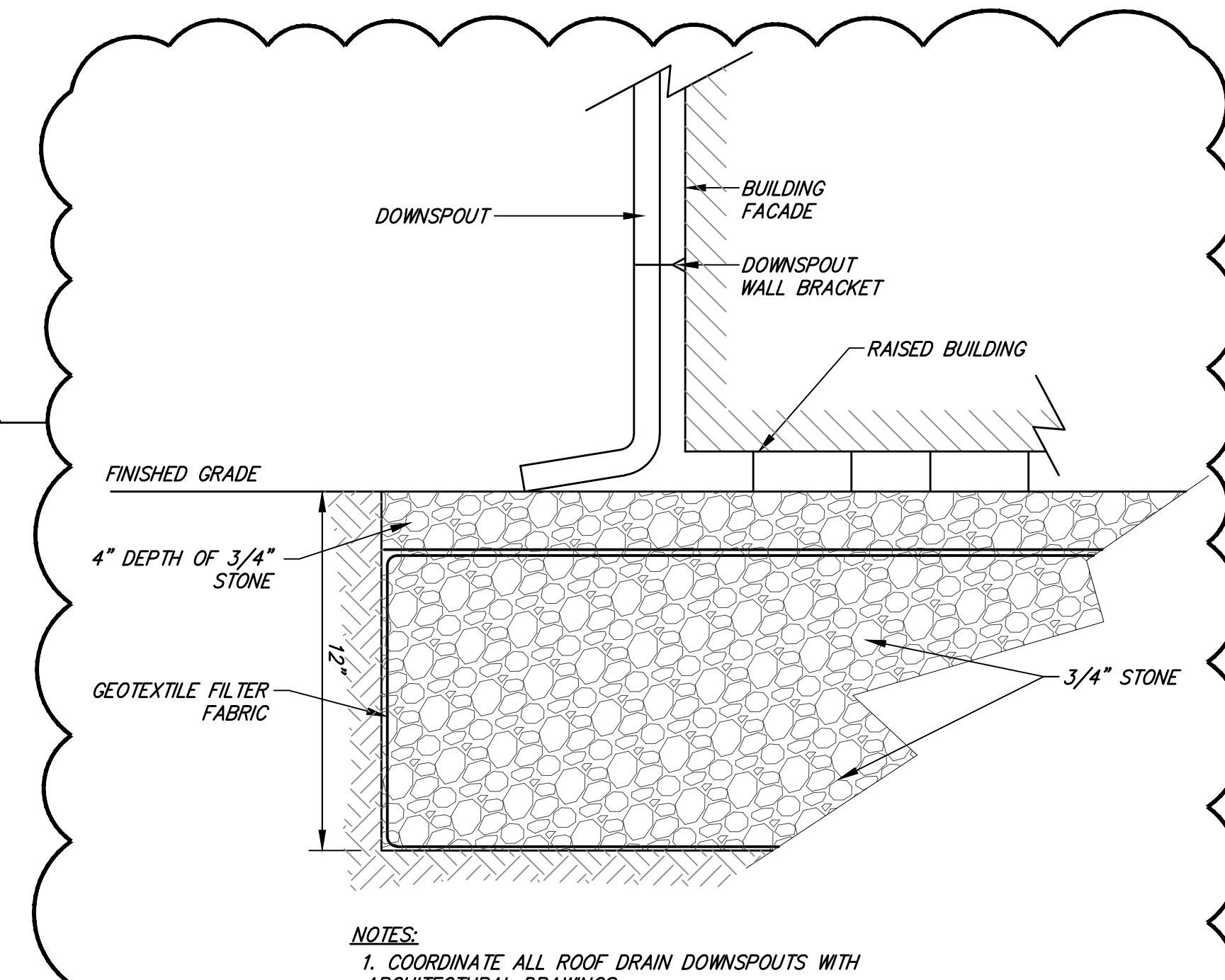

- NOTES:**
1. COORDINATE ALL ROOF DRAIN DOWNSPOUTS WITH ARCHITECTURAL DRAWINGS.

9 ROOF DRAIN TO CRUSHED STONE PAD
UNDER MODULAR BUILDING
NOT TO SCALE

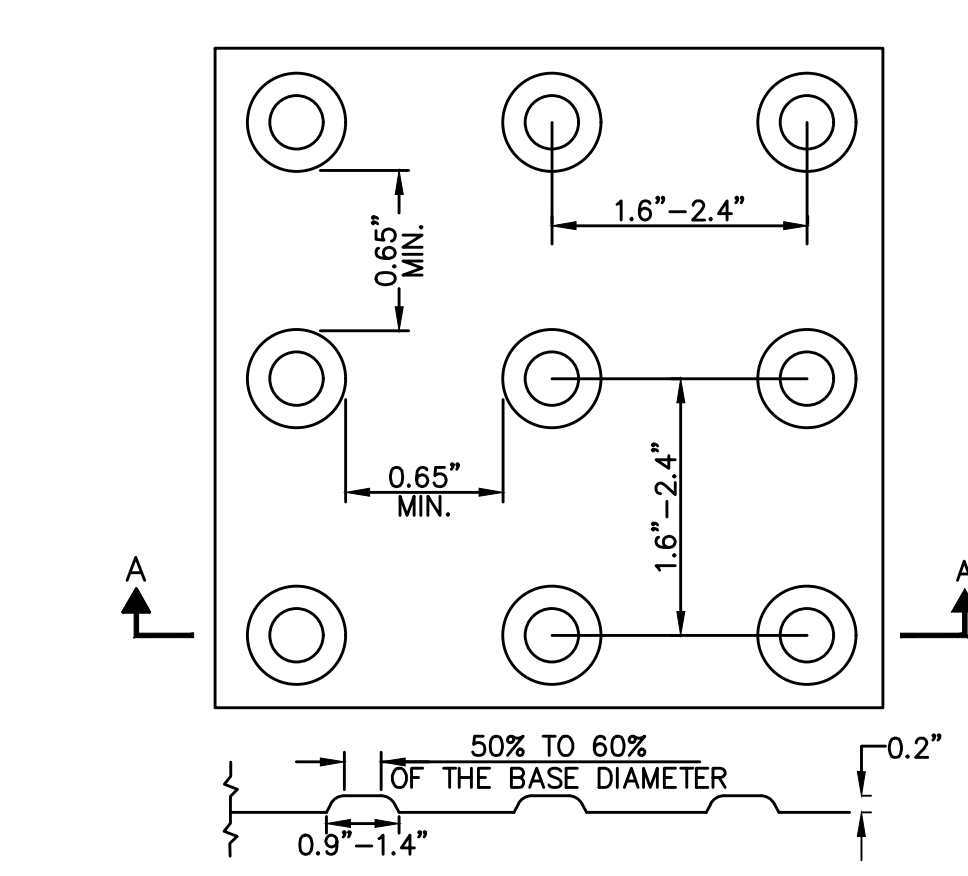

1 DETECTABLE WARNING PANEL
NOT TO SCALE

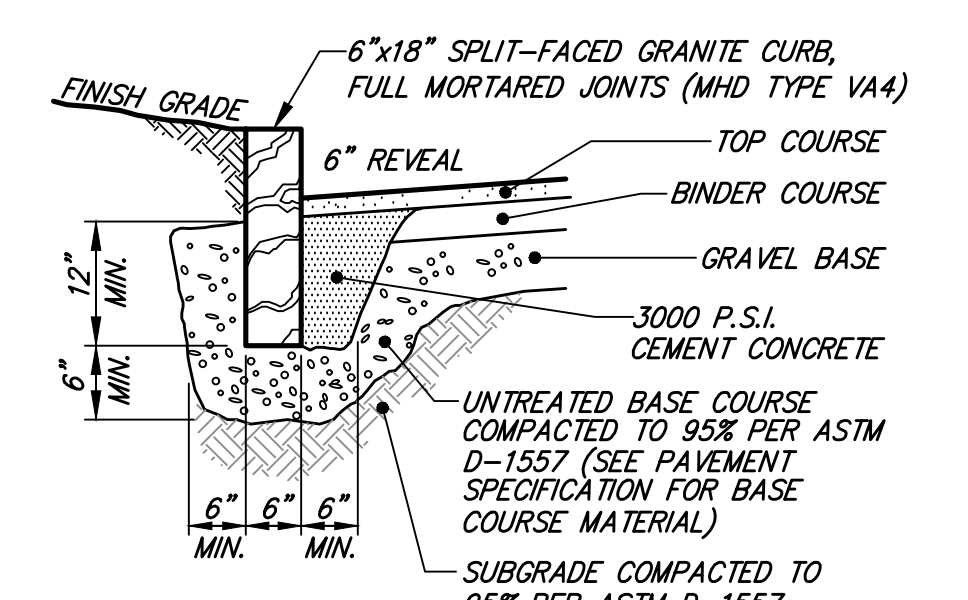

5 VERTICAL GRANITE CURB
CROSS SECTION
NOT TO SCALE

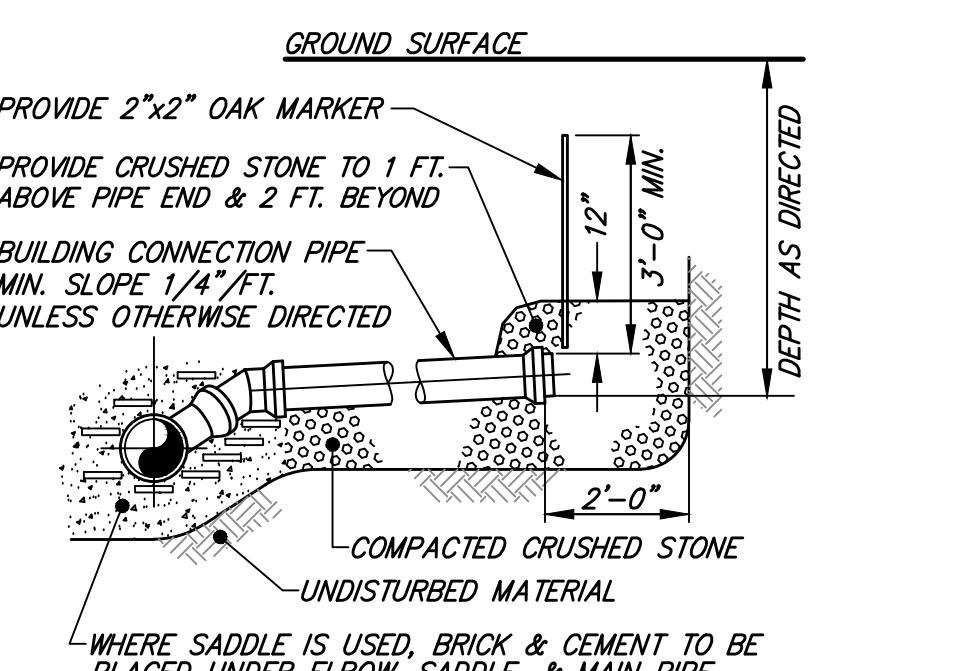
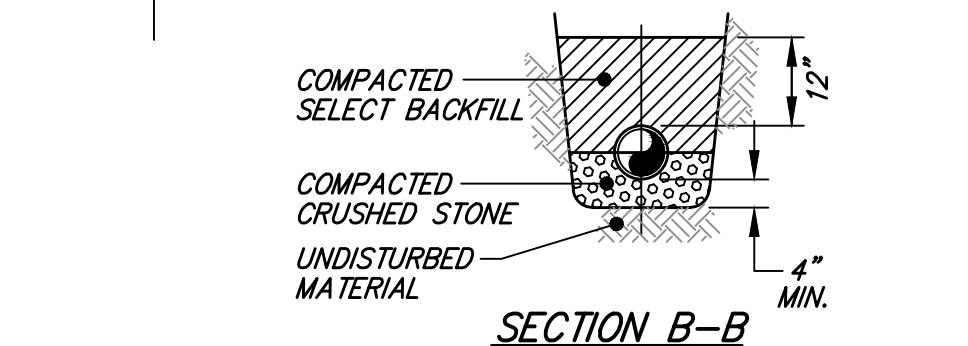
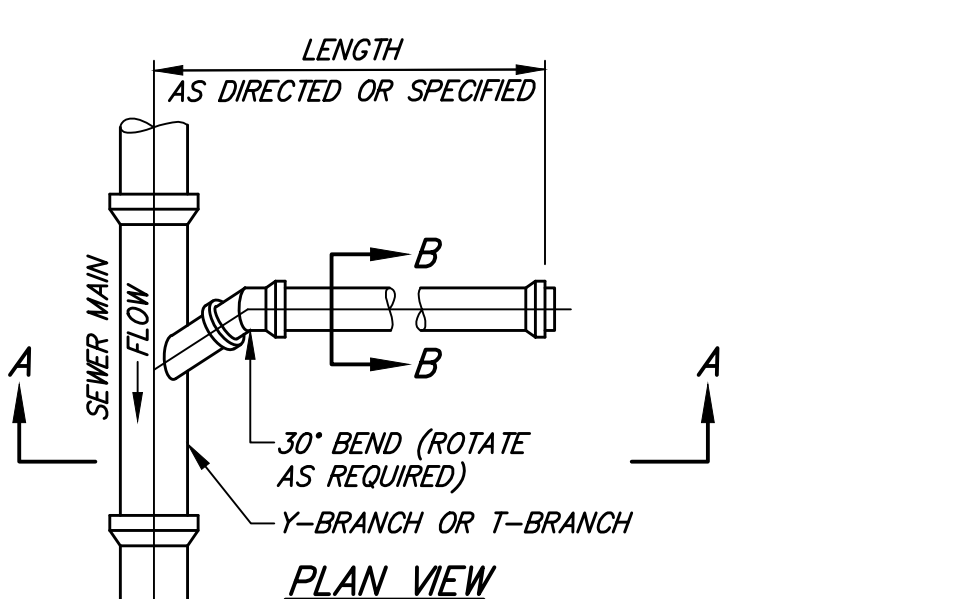

10 SEWER CONNECTION
NOT TO SCALE

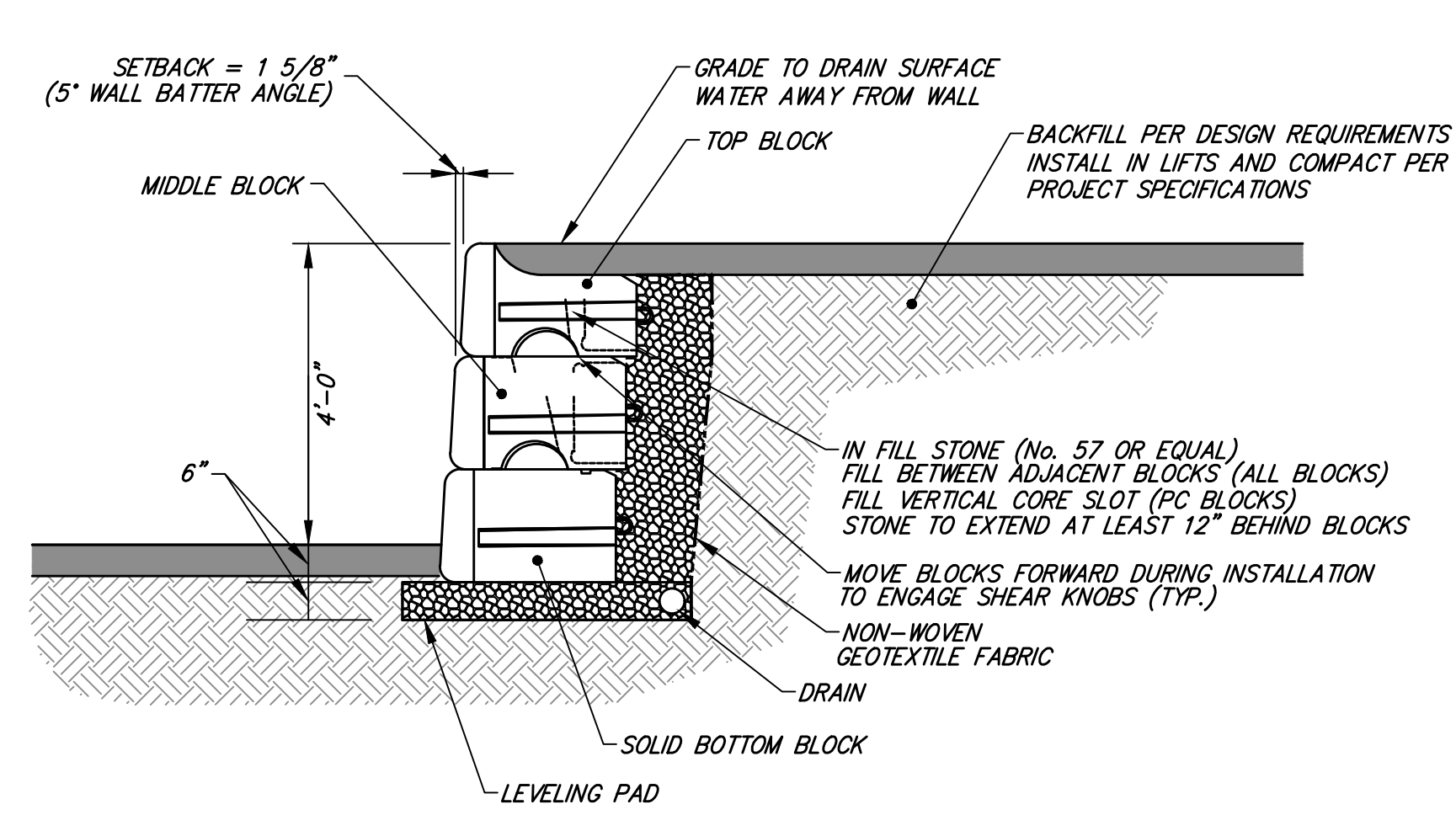

2 4' HIGH BLOCK RETAINING WALL
NOT TO SCALE

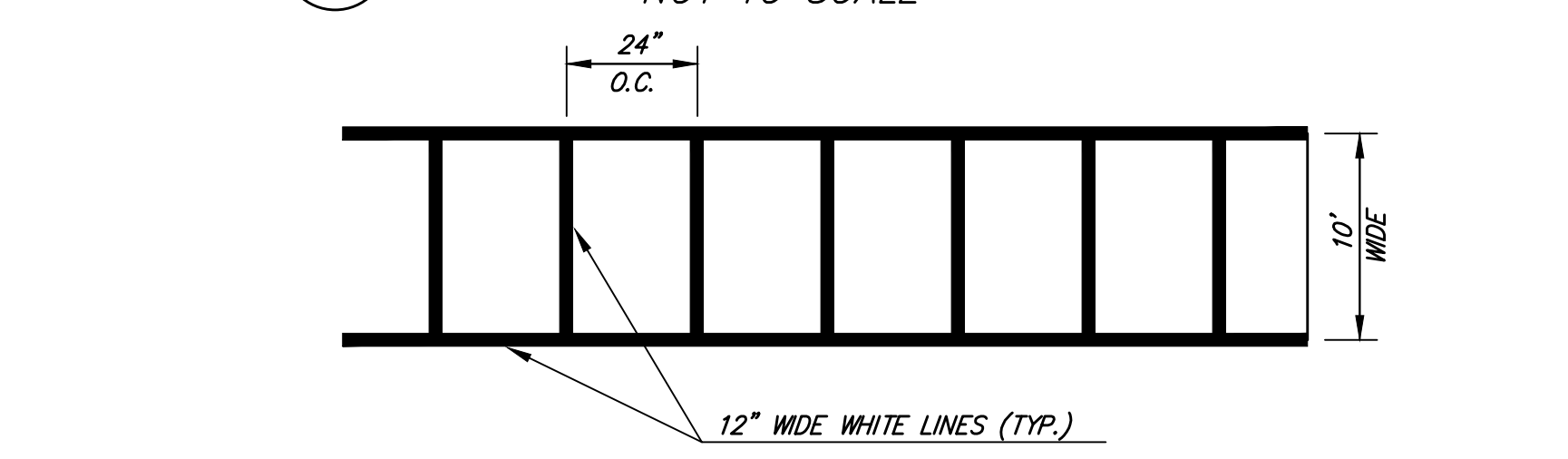

6 CROSSWALK STRIPING DETAIL
NOT TO SCALE

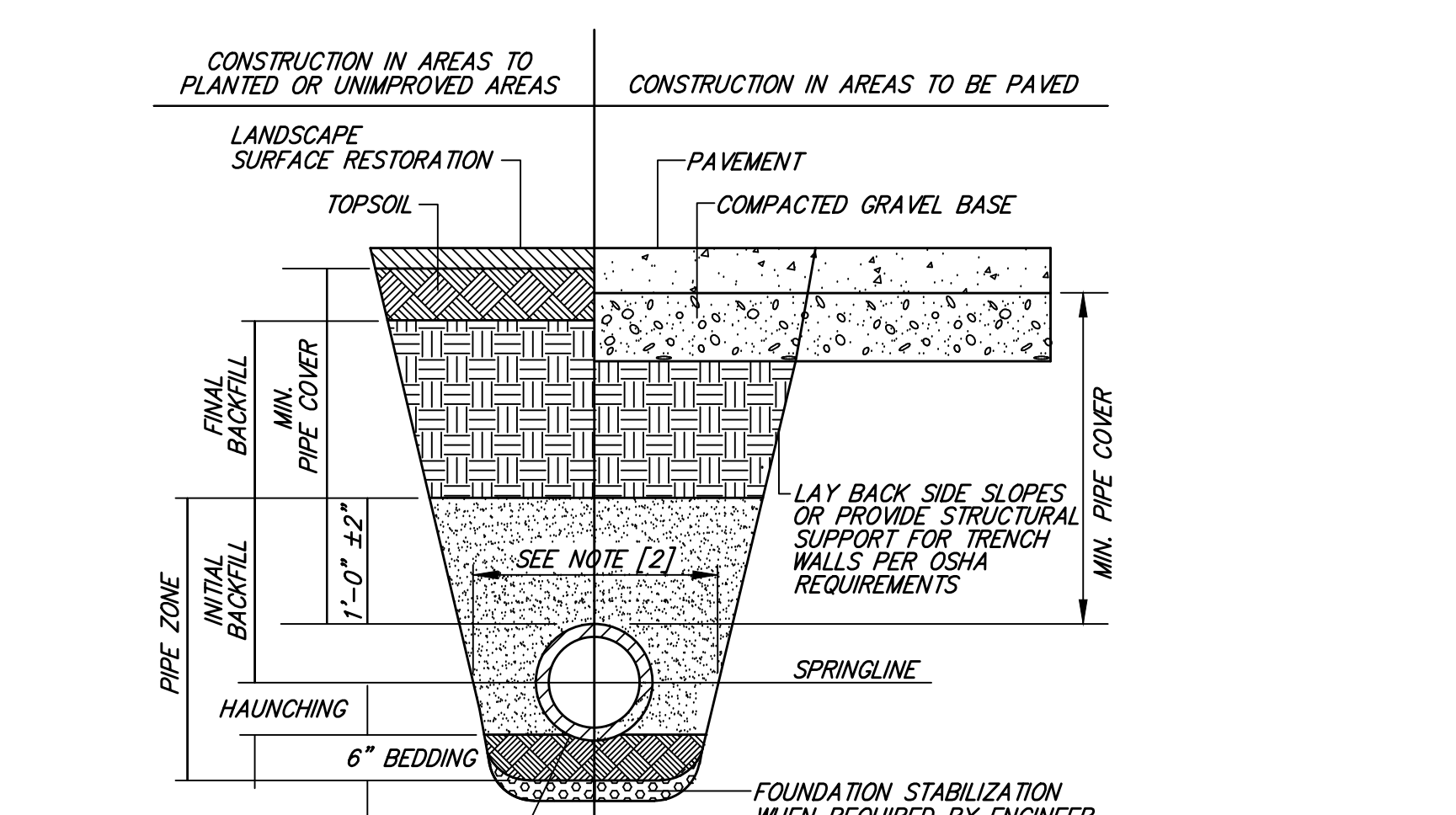

- NOTES:**
- [1] PLACE 3/4"± GRADED GRANULAR BACKFILL AT OPTIMUM MOISTURE IN HORIZONTAL, 8"-DEEP, LOOSE LAYERS; COMPACT TO 95% PER ASTM D-1557.
 - [2] MINIMUM WIDTH OF TRENCH MEASURED AT THE SPRINGLINE OF THE PIPE, INCLUDING ANY NECESSARY SHEATHING.

FOUNDATION, BEDDING, & BACKFILL MATERIALS		
PIPE MATERIAL	HDP, PVC	RC, DI
FOUNDATION STABILIZATION	[6]	[6]
BEDDING	[1]	[1]
HAUNCHING	[1]	[1]
INITIAL BACKFILL	[1]	[1]
FINAL BACKFILL	[4]	[4]
PIPE I.D.	LESS THAN 21"	O.D. + 12"
	21" TO 42"	O.D. + 24"
	GREATER THAN 42"	O.D. + 30"

- [3] INSTALL PIPE IN CENTER OF TRENCH.
- [4] IN PLANTED OR UNIMPROVED AREAS, USE ON-SITE EXCAVATED MATERIAL FOR FINAL BACKFILL. COMPACT TO 95% PER ASTM D-1557. IN PAVED AREAS, OBTAIN ENGINEER APPROVAL OF ON-SITE EXCAVATED MATERIALS FOR USE AS FINAL BACKFILL.
- [5] MINIMUM COVER OVER TOP OF PIPE:

PIPE MATERIAL	HDP, PVC	RC, DI
WATER	5'-0"	5'-0"
SEWER	4'-0"	4'-0"
DRAIN	1'-6"	1'-0"

[6] FOR FOUNDATION STABILIZATION, USE 2"± CRUSHED STONE.
11 PIPE TRENCH
TYPICAL CROSS SECTION
NOT TO SCALE