

# STONEFIELD

## STORMWATER OPERATIONS & MAINTENANCE PLAN PRIMROSE SCHOOL FRANCHISING COMPANY

PROPOSED CHILDCARE FACILITY  
PARCEL ID: 28-113  
885 MAIN STREET  
TOWN OF READING  
MIDDLESEX COUNTY, MASSACHUSETTS

PREPARED FOR:  
PRIMROSE SCHOOLS FRANCHISING COMPANY  
21 CONKLIN AVENUE  
WARREN, NEW JERSEY 07059

PREPARED BY:  
STONEFIELD ENGINEERING & DESIGN, LLC  
120 WASHINGTON STREET, SUITE 201  
SALEM, MASSACHUSETTS

REPORT DATE:  
MARCH 7, 2025

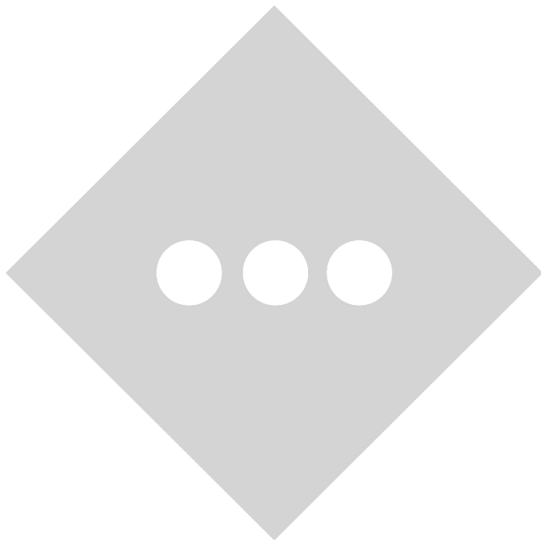

JOSHUA H. KLINE, PE  
MA PE LICENSE #53936

**REPORT CONTENTS**

**1.0 INTRODUCTION ..... 1**

    1.1 RESPONSIBILITY ..... 1

    1.2 DOCUMENTATION ..... 2

    1.3 CHANGES TO OPERATIONS & MAINTENANCE PLAN..... 2

**2.0 INSPECTION & MAINTENANCE OF STORMWATER SYSTEMS..... 3**

    2.1 DEEP SUMP CATCH BASINS ..... 3

    2.2 ISOLATOR ROW PLUS™ PRETREATMENT ..... 4

    2.3 SUBSURFACE INFILTRATION BASIN (CHAMBER SYSTEM – ADS STORMTECH)..... 6

**3.0 GENERAL SITE OPERATIONS & MAINTENANCE ..... 7**

    3.1 ONSITE CONVEYANCE SYSTEM..... 7

    FLARED END SECTIONS ..... 8

    3.2 VEGETATED AREAS ..... 8

    3.3 MAINTENANCE OF STREETS & PARKING AREAS..... 9

    3.4 WINTER MAINTENANCE AND SNOW & ICE MANAGEMENT ..... 11

**4.0 ESTIMATED ANNUAL BUDGET ..... 13**

**5.0 INSPECTION & LOGS OF PREVENTATIVE AND CORRECTIVE MEASURES .... 14**

**6.0 ANNUAL EVALUATION OF THE EFFECTIVENESS OF THE PLAN..... 15**

**APPENDICES**

**PROJECT FIGURES..... A**

**RADIUS MAP ..... FIGURE 1**

**USGS MAP ..... FIGURE 2**

**AERIAL MAP ..... FIGURE 3**

**FEMA MAP ..... FIGURE 4**

**SITE PLANS ..... B**

**SITE PLANS..... B-1**

**STORMWATER MANAGEMENT PLAN ..... B-2**

**SOIL EROSION AND SEDIMENT CONTROL PLANS ..... B-3**

**LANDSCAPING PLANS ..... B-4**

**STORMWATER BMP LOCATION EXHIBIT ..... C**

**STORMTECH ISOLATOR ROW MANUFACTURER SPECIFICATIONS..... D**

**INSPECTION CHECKLISTS ..... E**

**ANNUAL EVALUATION FORMS ..... F**

**ANNUAL EVALUATION RECORD ..... F-1**

**AMENDMENT LOG ..... F-2**

## **I.0 INTRODUCTION**

---

This Stormwater Operations & Maintenance Plan has been prepared to identify the operational and maintenance responsibilities for the proposed stormwater facilities for the development of the parcel located at 885 Main Street, Reading, Massachusetts. This Plan has been prepared in conjunction with the Land Development Plans and Stormwater Management Plan, prepared by Stonefield Engineering & Design LLC. and in accordance with the standards and regulations set forth by the Town of Reading and the Massachusetts Department of Environmental Protection (MASSDEP).

Operation and maintenance of the permanent stormwater control Best Management Practices (BMPs) shall be the responsibility of the operator of the project site at the time that the applicable maintenance is required. Stormwater management improvements associated with this development include the implementation of a subsurface infiltration basin (ADS Isolator Row Plus SC-800 Chambers) and deep sump catch basins with associated subsurface conveyance system. All guidelines, standards and requirements set forth in this Plan shall be implemented for all proposed stormwater infrastructure.

A copy of this report shall be kept on-site at all times both during and after construction. Upon reviewing agency approval, the title and date of the maintenance plan as well as the contact information of the current agent responsible for maintaining the stormwater management measures for the project shall be recorded (as deemed required).

### **I.1 RESPONSIBILITY**

The purpose of the Stormwater Operations and Maintenance (O&M) Plan is to ensure adequate inspection of the systems, removal of accumulated sediments, oils and debris, and implementation of corrective action and record keeping activities. The enclosed O&M activities will be performed by a Contract Operator for the scope of maintenance. The Contract Operator will be a professional engineer or other professional with expertise and experience with stormwater management facilities operation and maintenance. The Owner, its successors, and/or assigns shall be responsible for the maintenance of the stormwater infrastructure associated with the proposed site improvements. Adequate maintenance is defined in this document as good working condition.

The current responsible agent shall evaluate the maintenance plan for effectiveness at least annually and revise the plan, as necessary. A detailed, written log of all preventative and corrective maintenance performed for each stormwater management measure must be kept, including a record of all inspections and copies of maintenance-

related work orders. Upon request from a public entity with jurisdiction over the project area the responsible agent shall make available the maintenance plan and associate logs and other records for review.

**Responsible Agent:**

**Name:** Primrose Schools Franchising Company  
**Address:** 21 Conklin Lane, Warren, NJ  
**Contact:** TBD  
**Phone:** TBD  
**Email:** TBD

**I.2 DOCUMENTATION**

Quarterly Operation and Maintenance Record Log and Schedule will be kept by the Owner summarizing inspections, maintenance, repairs and any corrective actions taken. The log will include the date on which each inspection or maintenance task was performed, a description of the inspection findings or maintenance completed, and the name of the inspector or maintenance personnel performing the task. If a maintenance task requires the clean-out of any sediments or debris, the location where the sediment and debris was disposed after removal will be indicated. Sample Inspection and Maintenance Logs for each stormwater BMP are enclosed. Additionally, invoices and other documentation of performance of maintenance activities (e.g., sediment disposal) shall be kept by the Owner or the legally authorized representative. The documentation will be kept on file.

The site supervisor shall be responsible for ensuring that the scheduled tasks as described in this plan are appropriately completed and recorded in the Maintenance Log. Accurate records of all inspections, routine maintenance and repairs shall be documented and these records shall be available for inspection by members of the governing authority as designated by the Town of Reading, or their designated agent, upon request.

**I.3 CHANGES TO OPERATIONS & MAINTENANCE PLAN**

The Owner(s) and/or Responsible Agent shall notify the designated Governing Authority of any changes to the Operations & Maintenance Plan. Amendments to the Plan include but are not limited to changes in ownership, changes in assignment of financial responsibility, change in responsible parties, and modifications to the procedures outlined herein. Changes to the Plan shall be recorded on the Amendment Log in **APPENDIX [F]** of this Plan.

## **2.0 INSPECTION & MAINTENANCE OF STORMWATER SYSTEMS**

---

The Owner, Property Manager and maintenance staff will conduct the Operation and Maintenance program set forth in this document. The Owner or Property Manager will ensure that inspections and record keeping are timely and accurate, and that cleaning and maintenance are performed in accordance with the recommended frequency for each stormwater component. Inspection & Maintenance Log Forms (provided herein) shall include the date and the amount of the last significant storm event in excess of 1" of rain in a 24-hour period, physical conditions of the structures, depth of sediment in structures, evidence of overtopping or debris blockage and maintenance required of each structure.

The following areas, facilities and measures will be inspected by the Owner or Property Manager and maintained as specified below. The following guidelines are applicable to all known stormwater structures and facilities on the parcel. Identified deficiencies will be corrected. Accumulated sediments and debris will be properly handled and disposed of off-site, in accordance with local, state, and federal guidelines and regulations.

### **2.1 DEEP SUMP CATCH BASINS**

**Structures:** Three (3) Deep Sump Catch Basins

**Description:** Inspect or clean deep sump catch basins at least two (2) times per year and at the end of the foliage and snow-removal seasons. Sediments must also be removed annually or whenever the depth of deposits is greater than or equal to 50% the sump depth.

**Maintenance Equipment:** Vacuum trucks are the preferred method of cleaning as they remove trapped sediment and supernatant more efficiently than alternative methods such as clamshells. Vacuuming is a more time efficient process and is less likely to snap the cast iron hood within the deep sump catch basin. Clamshell buckets and vacuuming are both approved methods of removal of sediment within deep sump catch basins and may be used at the discretion of the responsible party. Precautions shall be taken to maintain the integrity of the oil trapping hoods during cleaning. Dispose of removed catch basin debris in accordance with local and state regulations.

**Maintenance Access:** Access to the Deep Sump Catch basins shall be provided via the associated frame and grate. Inlet grate shall be constructed of a durable material and fit tightly so as to not be dislodged by traffic, however, the grate must not be welded to the frame in order to provide access for maintenance personnel.

**Inspection & Maintenance Summary:** The table below provides a summary of inspection and maintenance actions and required frequency for Deep Sump Catch Basins:

**TABLE I: DEEP SUMP CATCH BASIN GENERAL MAINTENANCE SCHEDULE**

Frequency	Operation & Maintenance Activity
<ul style="list-style-type: none"> <li>• Minimum two times per year</li> <li>• At the end of the foliage &amp; snow removal seasons</li> <li>• After Street Sweeping</li> </ul>	<p><u>Deep Sump Catch Basin Inspection</u></p> <ul style="list-style-type: none"> <li>• Inspections shall be conducted in accordance with local and manufacturer recommendations.</li> <li>• Inspect inflow and outflow pipes for leaking, cracks, clogging, or other forms of damage or indication of malfunction.</li> <li>• Inspect condition of frame and grate and trap hood.</li> <li>• Inspect overall structure for structural integrity, cracks, settlement, leaking, sediment accumulation.</li> </ul>
<ul style="list-style-type: none"> <li>• Annually at minimum</li> <li>• At the end of the foliage &amp; snow removal seasons</li> <li>• When sediment accumulation is 50% of depth from lowest pipe invert to bottom of unit.</li> <li>• As needed after Street Sweeping</li> </ul>	<p><u>Preventive Maintenance Actions</u></p> <ul style="list-style-type: none"> <li>• Clean units / remove accumulated sediment.</li> <li>• Sediment and/or floatable pollutants shall be pumped from the basin and disposed of at an approved offsite facility in accordance with all applicable regulations.</li> <li>• During colder periods, catch basin grates must be kept free of snow and ice.</li> <li>• During warmer periods, catch basin grates must be kept free of leaves, litter, sand and other debris.</li> <li>• More frequent sweeping of paved surfaces will result in less accumulation of sediment in catch basins.</li> </ul>
<ul style="list-style-type: none"> <li>• Promptly as Needed</li> </ul>	<p><u>Corrective Maintenance Actions</u></p> <ul style="list-style-type: none"> <li>• Notify Owner of any structural damage or other indication of malfunction and of all system repairs needed in a timely manner.</li> <li>• Perform corrective maintenance activities as required on applicable system components in accordance with all applicable local and manufacturer recommendations. Responsible party shall thoroughly document all required and completed corrective actions including repair and replacement of system components.</li> </ul>

## 2.2 ISOLATOR ROW PLUS™ PRETREATMENT

**Structures:** One (1) ADS StormTech Isolator Row PLUS

- **Isolator Row for Infiltration Basin B-1**
  - Design Intent: Pretreat discharge prior to infiltration through Basin B-1.
  - Approximate Location: Directly in front of the proposed building
  - Composition: 6 Rows by 10 Chambers of ADS StormTech SC-800 Chambers

**Description:** The proposed ADS StormTech SC-800 infiltration basin is equipped with an Isolator Row PLUS, an Alternative Stormwater Technology. The Isolator Row should generally be inspected and maintained on the same schedule as the associated infiltration basin. Initially, the Isolator Row shall be inspected every 6 months for the first year of operation. Thereafter, it shall be inspected at minimum annually and after storms equal to or greater than the 1-year, 24-hour, Type III storm event. If sediment exceeds 3 inches throughout the length of the Isolator Row, clean-out should be performed. Isolator Row should be cleaned and maintained in accordance with manufacturer specifications as identified in **APPENDIX D**.

**Maintenance Equipment:** Subsurface Isolator Row Plus shall be cleared of accumulated and sediments through a JetVac process. Refer to enclosed manufacturer specifications for specific cleaning procedures using the JetVac as well as guidance on selection of an appropriate JetVac nozzle for the most efficient cleaning. Operator shall ensure precautions are taken to maintain the structural integrity of the Isolator Row and associated internal components during cleaning.

**Maintenance Access:** Access to the Isolator Row is provided via a 4’ diameter maintenance access manhole directly connected to the pretreatment chambers. There are additional inspection ports on each Isolator Row to perform inspections without the need for a confined space entry.

**Inspection & Maintenance Summary:** The table below provides a brief summary of inspection and maintenance actions for the Isolator Row Plus. Operator shall refer to manufacturer specifications enclosed herein for specific means and methods inspection and maintenance.

**TABLE 2: ISOLATOR ROW PLUS™ GENERAL MAINTENANCE SCHEDULE \***

Frequency	Operation & Maintenance Activity
<ul style="list-style-type: none"> <li>• Annually</li> <li>• After rainfall equal to or greater than the 1-year, 24-hour, Type III event</li> </ul>	<u>Inspection Actions</u> <ul style="list-style-type: none"> <li>• Inspect filter fabric for clogging, tearing, or other damage.</li> <li>• Inspect chambers for sediment, debris and other obstructions.</li> <li>• Evaluate structural integrity of overall system and inspect for cracks, settlement, leaking, or other indications of malfunction.</li> </ul>
<ul style="list-style-type: none"> <li>• Annually</li> </ul>	<u>Preventive Maintenance Actions</u> <ul style="list-style-type: none"> <li>• Perform a clean-out if depth of sediment exceeds 3” throughout the length of the row.</li> <li>• Remove trash, debris, organic matter and other obstructions.</li> <li>• Remove and replace degraded perimeter stone as required.</li> <li>• Remove and replace damaged filter fabric as required.</li> </ul>
<ul style="list-style-type: none"> <li>• Promptly as Needed</li> </ul>	<u>Corrective Maintenance Actions</u> <ul style="list-style-type: none"> <li>• Notify Owner of any structural damage or other indication of malfunction and of all system repairs needed in a timely manner.</li> <li>• Perform corrective maintenance activities as required on applicable system components in accordance with all applicable local and manufacturer recommendations. Responsible party shall thoroughly document all required and</li> </ul>

	completed corrective actions including repair and replacement of system components.
--	---

**\*This table is a brief summary of inspection and maintenance measures required for the Isolator Row Plus and is not intended to replace the enclosed manufacturer specifications. Operator is responsible for reviewing and adhering to all manufacturer specifications for the Isolator Row PLUS™.**

### 2.3 SUBSURFACE INFILTRATION BASIN (*CHAMBER SYSTEM – ADS STORMTECH*)

**Structures:** Subsurface Infiltration Chambers

- **Infiltration Basin B-1**
  - Design Intent: Capture, treat & infiltrate discharge from development area including the rooftop, parking lot and portions of open space.
  - Approximate Location: Under the parking lot, directly in front of the proposed building. Refer to **APPENDIX C** for a BMP location exhibit.
  - Composition: 60 ADS SC-800 Chambers (10 rows of 6 chambers)

**Description:** As they are underground, subsurface infiltration systems are difficult to maintain and are prone to clogging and failure; therefore, aggressive and timely maintenance is required. Inspect the infiltration basins annually and after storms equal to or greater than the 1-year, 24-hour, Type III storm event. Ensure that the access points to components are not compromised, that inlet and outlet pipes are functioning as expected, standing water is not present within the infiltration BMP 72 hours after a rain event, there are no signs of illicit discharges or vandalism, there is no subsidence, erosion, or cracking of structures, there is no leakage through the structure, and evaluate the level of sedimentation and trash accumulation for acceptable levels. Each basin is equipped with an Isolator Row that should be cleaned and maintained on the same schedule as the infiltration basin and in accordance with manufacturer specifications as identified in **APPENDIX D**.

**Maintenance Equipment:** Subsurface infiltration systems shall be cleared of accumulated and sediments through the use of a vacuum truck and hose. Precautions shall be taken to maintain the structural integrity of the system and associated internal equipment during cleaning.

**Maintenance Access:** Access to the subsurface infiltration basins shall be provided via the access risers installed on each system. The basins are also equipped with inspection ports at each end for more frequent inspections.

**Inspection & Maintenance Summary:** The table below provides a summary of inspection and maintenance actions and required frequency for Subsurface Infiltration Basins:

**TABLE 3: SUBSURFACE INFILTRATION BASIN GENERAL MAINTENANCE SCHEDULE**

Frequency	Operation & Maintenance Activity
<ul style="list-style-type: none"> <li>• Annually</li> <li>• After rainfall equal to or greater than the 1-year, 24-hour, Type III event</li> </ul>	<p><u>Infiltration Basin Inspection</u></p> <ul style="list-style-type: none"> <li>• Inspect inflow pipes for leaking, cracks, clogging, or other forms of damage or indication of malfunction.</li> <li>• Inspect basin for sediment, debris, trash, organic matter and other obstructions.</li> <li>• Inspect soil and infiltration functionality. Ensure no standing water remains within the basin after 72 hours.</li> <li>• Inspect condition of frame and lid of access structures.</li> <li>• Inspect overall structure for structural integrity, cracks, settlement, leaking, sediment accumulation.</li> <li>• Inspect internal components for signs of damage or loss of functionality.</li> <li>• Inspect Isolator Row in accordance with manufacturer specifications.</li> </ul>
<ul style="list-style-type: none"> <li>• Annually</li> </ul>	<p><u>Preventive Maintenance Actions</u></p> <ul style="list-style-type: none"> <li>• Remove trash, debris, organic matter and other obstructions.</li> <li>• Remove and replace degraded perimeter stone.</li> <li>• Repair damage to components as required.</li> <li>• Maintain Isolator Row in accordance with manufacturer specifications.</li> </ul>
<ul style="list-style-type: none"> <li>• Annually</li> </ul>	<p><u>Inspect &amp; Clean Pretreatment Devices</u></p> <ul style="list-style-type: none"> <li>• Deep Sump Catch Basins                             <ul style="list-style-type: none"> <li>○ Refer to Section 2.1 of this Plan for specific means and methods of operations &amp; maintenance of deep sump catch basins.</li> </ul> </li> <li>• <u>ADS Isolator Row PLUS</u> <ul style="list-style-type: none"> <li>○ Refer to Section 2.2 of this Plan and the enclosed manufacturer field manual for specific means and methods of operations &amp; maintenance of ADS Isolator Rows</li> </ul> </li> </ul>
<ul style="list-style-type: none"> <li>• Promptly as Needed</li> </ul>	<p><u>Corrective Maintenance Actions</u></p> <ul style="list-style-type: none"> <li>• Notify Owner of any structural damage or other indication of malfunction and of all system repairs needed in a timely manner.</li> <li>• Perform corrective maintenance activities as required on applicable system components in accordance with all applicable local and manufacturer recommendations. Responsible party shall thoroughly document all required and completed corrective actions including repair and replacement of system components.</li> </ul>

### **3.0 GENERAL SITE OPERATIONS & MAINTENANCE**

#### **3.1 ONSITE CONVEYANCE SYSTEM**

##### **STORM DRAIN PIPING**

The proposed site storm drain system is comprised of a network of piping and structures discharging to two (2) subsurface infiltration systems.

- Sediments and hydrocarbons will be properly handled and disposed of off-site, in accordance with local, state and federal guidelines and regulations.
- If there is evidence of clogging, blockages, or other failure of the conveyance system, appropriate remediation measures shall be conducted in a timely manner. All corrective measures taken shall be appropriately logged in accordance with this Plan.

### **FLARED END SECTIONS**

Two (2) flared end sections are proposed as part of the new development.

- Flared end sections shall be inspected quarterly or as necessary to ensure that they are working in their intended fashion.
- Remove and dispose of any trash or debris at outfall.
- Remove any obstructions to flow; remove accumulated sediments and debris at the outlet and within the conduit and repair any erosion damage.
- Maintain riprap pad below flared end section and replace washout as needed.

### **ROOF DRAIN LEADERS**

Roof runoff from the proposed building is directed to the proposed conveyance system via roof leaders and ultimately to Basin B-1. The Property Owner shall be responsible for maintenance of all material associated with roof leaders.

- Perform routine roof drain inspections and cleanings multiple times per year as needed and at the end of the foliage and snow removal seasons.
- Keep roofs clean and free of debris.
- Keep roof drainage systems clear.
- Keep roof access limited to only those responsible for maintenance and cleaning.
- Keep gutters clear of leaves and debris.

## **3.2 VEGETATED AREAS**

The maintenance of vegetated areas is essential in maintaining the functionality of the stormwater management system. This includes the health/density of vegetative cover and activities such as the application and disposal of lawn and garden care products, disposal of leaves and yard trimmings and proper aeration of soils.

It is the responsibility of the Property Owner to coordinate Landscape Maintenance of the onsite open space areas. Post-construction conditions shall incorporate a mix of existing and proposed landscape features and open space. This Plan is inclusive of all vegetation, both existing and proposed. At a minimum, the following maintenance and operations requirements shall met be during and after construction period:

- Inspect slopes and embankments early in the growing season to identify active or potential erosion problems. Replant bare areas or areas with sparse growth. If erosion is evident, armor the area with an appropriate lining or riprap stone.
- Inspect planted areas on a semi-annual basis and remove any litter.
- Maintain planted areas adjacent to pavement to prevent soil washout.
- Immediately clean any soil deposited on pavement.
- Re-seed bare areas; install appropriate erosion control measures when native soil is exposed, or erosion channels are forming.
- Plant alternative mixture of grass species in the event of unsuccessful establishment.
- The grass vegetation should be cut to a height between three and four inches.
- Pesticide/Herbicide Usage – No pesticides are to be used unless a single spot treatment is required for a specific control application unless approved and applied by a licensed professional.
- No pesticides or herbicides are allowed within the 100' adjacent upland resource area property without prior approval of the Governing Authority unless approved and applied by a licensed professional.
- Fertilizer usage should be avoided. If deemed necessary, fertilizer may only be of the low nitrogen and phosphorous variety. Fertilizer may be used to begin the establishment of vegetation in bare or damaged areas but should not be applied on a regular basis unless necessary.
- Fertilizer applications shall be limited to the spring and early fall and applied per the manufacturers' specifications. Nitrogen content shall not exceed 25% with ratios for Nitrogen, Phosphorus, and Potassium at 3-1-2 or 3-1-1. It is also recommended that at least 30%-50% of total nitrogen be slow release.
- Annual application of compost amendments and aeration are recommended.

### **3.3 MAINTENANCE OF STREETS & PARKING AREAS**

Roadways with curbs and catch basins must be swept at a minimum of once per year. Roadways with curbs and catch basins that discharge to nitrogen or phosphorus impaired waters, or their tributaries are swept at a minimum of twice per year, once in the spring and once in the fall. Sweeping on central pedestrian pathway, used for emergency vehicles only, must be conducted on an as-needed basis. All street sweepings collected must be disposed of in accordance with local and state regulations. The responsible party may temporarily store street sweepings in

labor yards, but street sweepings must be disposed of offsite in a reasonable timeframe. Street sweepings may not be disposed of on parking lots or lands.

The following minimum maintenance measures shall be implemented:

- Sweep or vacuum standard asphalt pavement areas with a rotary brush sweeper (or another method approved by licensed professional) and properly dispose of removed material.
- Minimum recommended sweeping schedule:
  - October / November
  - April / May
  - More frequent sweeping of paved surfaces will result in less accumulation in catch basins, less cleaning of subsurface structures, and less disposal costs.
- Check dumpster areas frequently for spillage and/or pavement staining and clean, as necessary.
- No coal-tar, petroleum-based, or other parking lot “sealants” are permitted to be used on-site unless approved by local authority. Normal maintenance activities intended to extend the life expectancy of the pavement surfaces including the use of bitumen asphalt to seal developing cracks, asphalt repair are not subject to this special condition.

The following street and parking lot sweeping procedures shall be performed to reduce the discharge of pollutants:

### **Sweeping**

- Street sweeping will be conducted in dry weather. Sweeping will not be conducted during or immediately after rainstorms.
- Dry cleaning methods will be used whenever possible with the exception of very fine water spray for dust control. Avoid wet cleaning or flushing of the pavement.
- When necessary, parking bans will be enacted to facilitate sweeping on busy streets.
- More frequent sweeping of paved surfaces will result in less accumulation in catch basins. Sweeping will be conducted in a manner that avoids depositing debris into storm drains. Deep sump catch basins shall be inspected and/or cleaned as needed after street sweeping concludes in accordance with the procedures set forth in *Section 2.1 Deep Sump Catch Basins* of this Plan.
- Sweeping shall generally be conducted with a vacuum sweeper, however alternative sweeping equipment (mechanical, regenerative air, vacuum filter, tandem sweeping) may be selected depending on the level of debris. Brush alignment, sweeper speed, rotation rate, and sweeping patterns will be set to optimize levels to manage debris.
- Sweeping equipment will be routinely inspected and maintained to reduce the potential for leaks.

## **Disposal**

- If street sweepings are reused, e.g., as anti-skid material or to fill in parking lots, they will be properly filtered to remove solid waste, such as paper or trash, in accordance with their intended reuse. All reuse and/or disposal of street sweeping will be managed in accordance with current local and state policies and regulations.
- Street sweepings can be stored for up to one year in approved temporary storage areas. Storage areas will be protected to prevent erosion and runoff and should be located away from wetland resource areas and buffer zones, surface water, or groundwater.
- Sweepings are classified as solid waste and are disposed of at solid waste disposal sites.

## **3.4 WINTER MAINTENANCE AND SNOW & ICE MANAGEMENT**

It is the responsibility of the Property Owner to contract with a professional snow removal/winter conditions management contractor to treat the paved parking and walking areas within the developed area for safe access during winter conditions. The contractor is responsible for minimizing de-icing applications while ensuring safe vehicle and pedestrian access to onsite facilities.

Snow storage and removal shall be conducted in accordance with the following minimum requirements:

- Snow will be stored in areas that do not block or hinder access to any structure or accessory facility.
- Snow storage areas will be managed to prevent blockage of storm drain catch basins, stormwater drainage channels, and on-street parking. Snow combined with sand and debris may block a storm drainage system, diminishing the drainage capacity of the system and causing localized flooding.
  - Storm drain catch basins and stormwater management systems shall be inspected and cleaned as needed at the end of the snow removal season in accordance with the procedures outlined in this Plan.
- Sand and debris deposited on vegetated or paved areas shall be cleared from the site and properly disposed of at the end of the snow season, no later than springtime.
- Snow shall not be dumped into any waterbody, pond, or wetland resource area.
- Snow shall not be dumped within a Wellhead Protection Area (WHPA) of a public water supply or within 200 feet of a private well, where road salt may contaminate water supplies.
- Snow shall not be dumped in sanitary landfills and gravel pits.

In addition to snow removal, potentially icy and unsafe paved surfaces are addressed as follows:

## **STORMWATER OPERATIONS & MAINTENANCE PLAN**

PRIMROSE SCHOOL FRANCHISING COMPANY

READING, MASSACHUSETTS

MARCH 7, 2025

- The de-icing program consists of two treatment zones: The largest area, parking and vehicle circulation areas, and the smaller area, the sidewalks/front doors of the facility.
- The parking and vehicle circulation areas within the development will be treated with approved treatment product mixed with sand. Per deicing event up to 200 gallons per acre may be applied.
- The front door entrances and sidewalks of commercial units will have a non-sodium pelletized de-icing material that may contain calcium chloride or magnesium chloride as the active ice melting ingredient. The pellets are broadcast at a rate up to 1 lb. per 75-100 square feet.
- Only calcium or magnesium-based de-icing chemicals shall be used on surfaces where runoff/drainage will discharge into any wetland resources, or the 100' adjacent upland resource area.

The following winter maintenance procedures shall be performed to reduce the discharge of pollutants:

- Minimize the use and optimize the application of sodium chloride and other salt (while maintaining public safety) and consider opportunities for use of alternative methods.
- Optimize sand and/or chemical application rates through the use, where practicable, of automated application equipment (e.g., zero velocity spreaders), anti-icing and pre-wetting techniques. Implementation of pavement management systems, and alternate chemicals. Maintain records of the application of sand, anti-icing and/or de-icing chemicals to document the reduction of chemicals to meet established goals.
- Prevent exposure of de-icing product (salt, sand, or alternative products) storage piles to precipitation by enclosing or covering the storage piles. Implement good housekeeping, diversions, containment, or other measures to minimize exposure resulting from adding to or removing materials from the pile. Store piles in such a manner as not to impact surface water resources, groundwater resources, recharge areas, and wells.

## 4.0 ESTIMATED ANNUAL BUDGET

---

The Owner and/or the Responsible Agent should perform a cost analysis and establish the annual operation and maintenance budget for the site. Once the budget has been established the below breakdown can be utilized to help track yearly costs for various onsite features and can be updated within **Table 4**.

The below values are subject to modification upon establishment of party responsible for completing associated work and/or consultation from manufacturers or responsible local authorities. Certain factors are not considered in the below estimates that may have significant cost implications. For example, removal and disposal of catch basin cleanings and sediment must be completed in accordance with local regulations and taken to a facility permitted by MassDEP to accept solid waste; the cost, policy, requirements, proximity or other factors of the specific disposal facility is not able to be accurately accounted for at the time of this Plan. Significant corrective measures such as unforeseen structural repairs may not be considered in initial estimates.

**TABLE 4: OPERATION AND MAINTENANCE BUDGET**

<b>System / Feature</b>	<b>Approximate Cost / Year</b>
Infiltration Basin Inspection & Maintenance	--
Hood & Sump Inspection & Maintenance	--
Conveyance System Inspection & Maintenance	--
Sediment Debris and Trash Removal/Disposal	--
Landscape & Vegetation Inspection & Maintenance	--
Street Sweeping	--
Winter Maintenance / Snow & Ice Management	--

## **5.0 INSPECTION & LOGS OF PREVENTATIVE AND CORRECTIVE MEASURES**

---

The person responsible for maintenance shall maintain a detailed log of all preventative and corrective maintenance for the structural stormwater management measures incorporated into the design of the development, including a record of all inspections and copies of all maintenance-related work orders.

A maintenance plan shall include a schedule of regular inspections and tasks, and detailed logs of all preventative and corrective maintenance performed on the stormwater management measure, including all maintenance-related work orders. The person with maintenance responsibility must retain and, upon request, make available the maintenance plan and associated logs and other records for review by a public entity with administrative, health, environmental, or safety authority over the site.

All inspection and maintenance activities shall be recorded to document frequency of inspection and maintenance, and implementation of corrective action. All regularly scheduled inspections, inspections following major storm events, maintenance activities, and repairs shall be recorded. General Inspection and Maintenance Logs for each Stormwater BMP can be found in **APPENDIX E** of this Plan. The enclosed general log forms shall be considered a minimum standard for recording purposes; the Operator and Inspection/Maintenance Personnel are strongly encouraged to supplement the Log with additional notes and photos.

## **6.0 ANNUAL EVALUATION OF THE EFFECTIVENESS OF THE PLAN**

---

The person responsible for maintenance shall evaluate the effectiveness of the maintenance plan at least once per year and adjust the plan and the deed as needed. The responsible party should evaluate the effectiveness of the maintenance plan by comparing the maintenance plan with the actual performance of the maintenance. The items to evaluate may include, but not limited to:

- Whether the inspections have been performed as scheduled;
- Whether the preventive maintenance has been performed as scheduled;
- Whether the frequency of preventative maintenance needs to increase or decrease;
- Whether the planned resources were enough to perform the maintenance;
- Whether the repairs were completed on time;
- Whether the actual cost was consistent with the estimated cost;
- Whether the inspection, maintenance, and repair records have been kept.

If actual performance of those items has been deviated from the maintenance plan, the responsible party should find the causes and implement solutions in a revised maintenance plan. Should modifications to the Plan be deemed necessary to ensure longevity of the site systems, the changes should be noted within the enclosed Amendment Log in **APPENDIX F**.

# **APPENDIX A**

## **PROJECT FIGURES**

### **INVENTORY**

**FIGURE 1: RADIUS MAP**

**FIGURE 2: USGS MAP**

**FIGURE 3: AERIAL LOCATION MAP**

**FIGURE 4: FEMA MAP**



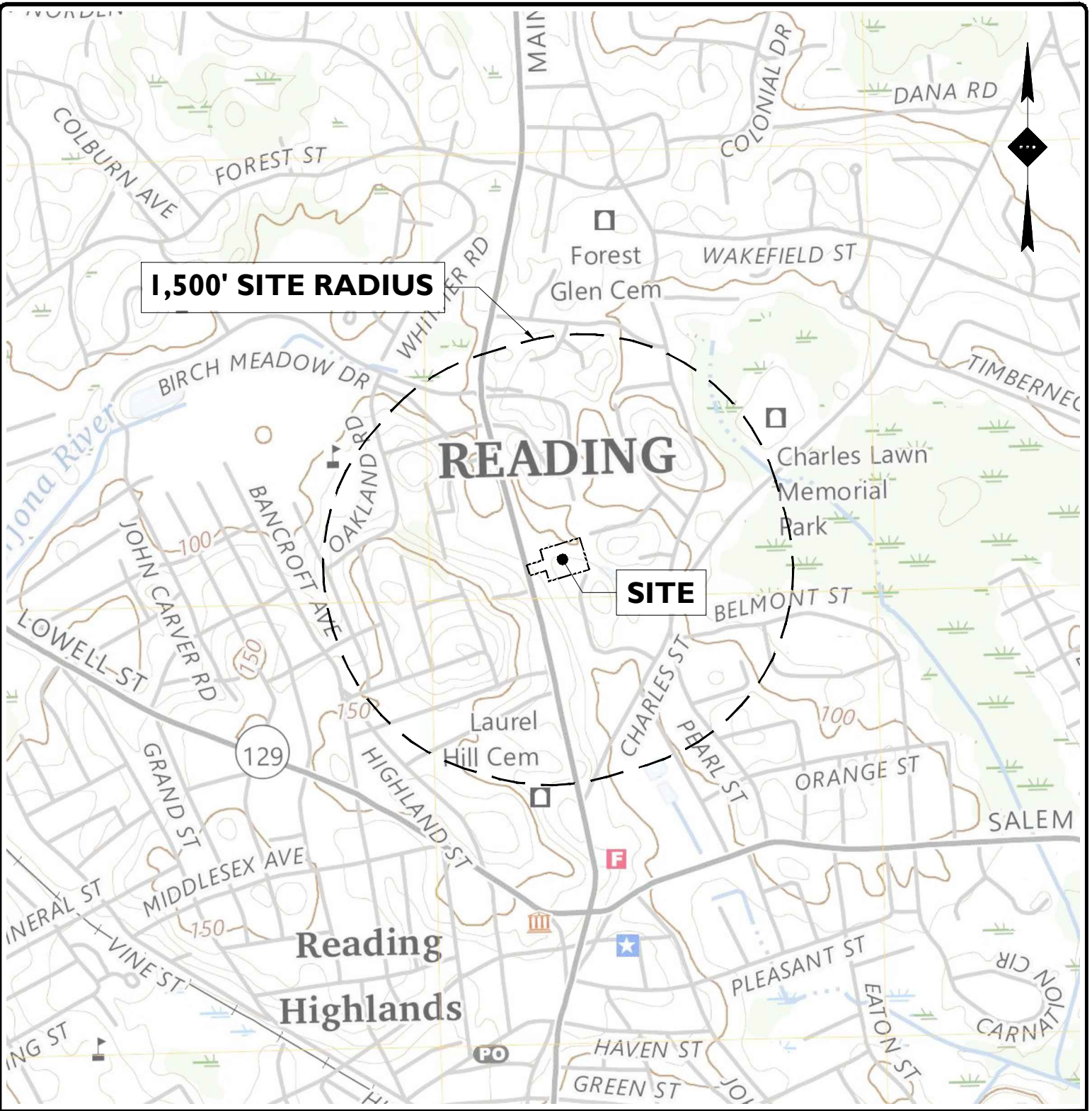

**1,500' SITE RADIUS**

**SITE**

**READING**

**Reading  
Highlands**



GRAPHIC SCALE IN FEET  
1" = 1000'

**USGS QUAD MAP**

SOURCE: USGS READING QUADRANGLE MASSACHUSETTS 7.5-MINUTE SERIES

**PRIMROSE SCHOOLS FRANCHISING COMPANY  
PROPOSED CHILD DAY CARE FACILITY**



PARCEL ID: 28-113  
885 MAIN STREET, TOWN OF READING  
MIDDLESEX COUNTY, MASSACHUSETTS

<b>DRAWN BY:</b>	SCL
<b>CHECKED BY:</b>	JHK
<b>DATE:</b>	02/27/2025
<b>SCALE:</b>	1" = 1000'
<b>PROJECT ID:</b>	BOS-240115

**STONEFIELD**  
engineering & design

Rutherford, NJ · New York, NY · Salem, MA  
Princeton, NJ · Tampa, FL · Birmingham, MI  
www.stonefielddeng.com

120 Washington Street, Salem, MA 01970  
Phone 617.203.2076

Z:\Boston\BOS\240115 Primrose Schools - 885 Main Street, Reading, MA\CADD\Exhibit\Project Maps\2025-02-27 Project Maps.dwg

500' SITE RADIUS

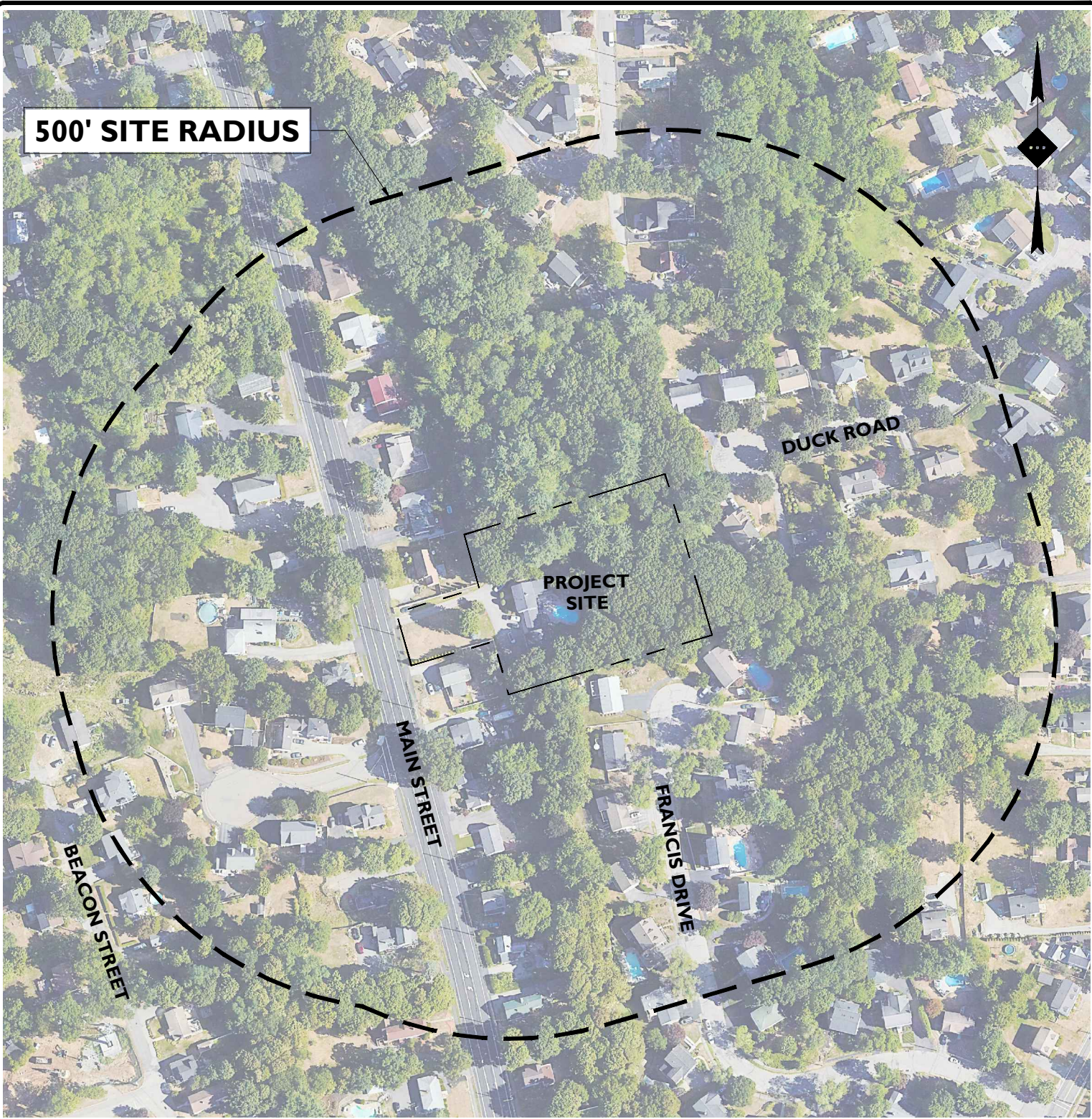

PROJECT SITE

DUCK ROAD

MAIN STREET

FRANCIS DRIVE

BEACON STREET



GRAPHIC SCALE IN FEET

1" = 200'

# AERIAL MAP

SOURCE: GOOGLE EARTH IMAGE, DATED 06/13/2024

## PRIMROSE SCHOOLS FRANCHISING COMPANY PROPOSED CHILD DAY CARE FACILITY

PARCEL ID: 28-113  
885 MAIN STREET, TOWN OF READING  
MIDDLESEX COUNTY, MASSACHUSETTS



<b>DRAWN BY:</b>	SCL
<b>CHECKED BY:</b>	JHK
<b>DATE:</b>	02/27/2025
<b>SCALE:</b>	1" = 200'
<b>PROJECT ID:</b>	BOS-240115



**STONEFIELD**  
engineering & design

Rutherford, NJ · New York, NY · Salem, MA  
Princeton, NJ · Tampa, FL · Birmingham, MI  
[www.stonefielddeng.com](http://www.stonefielddeng.com)

120 Washington Street, Suite 201, Salem, MA 01970  
Phone 617.203.2076

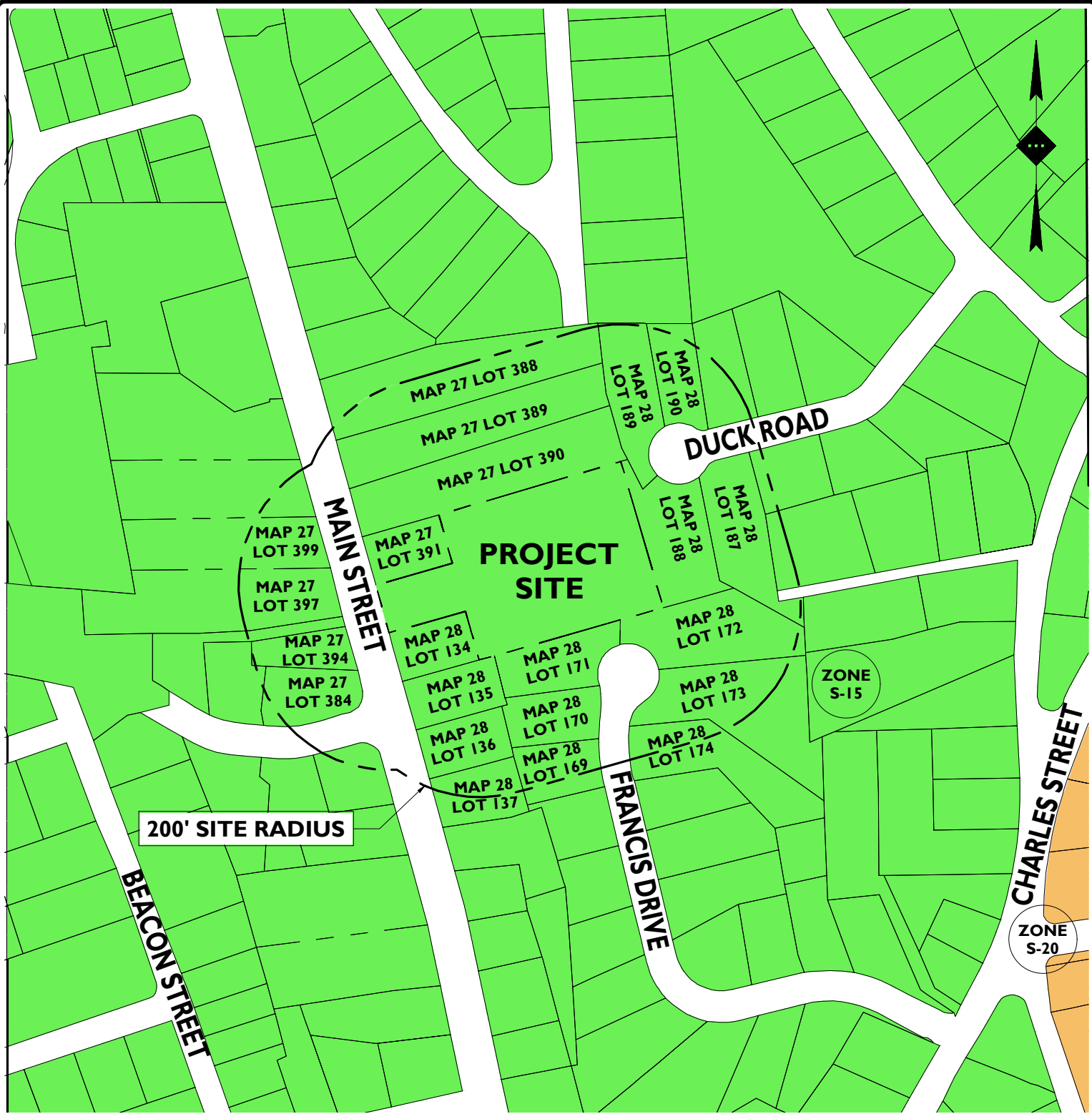

Z:\Boston\BOS\2024\BOS-240115 Primrose Schools - 885 Main Street, Reading, MA\CADD\Exhibit\Project Maps\2025-02-27\_Project Maps.dwg

# TAX & ZONING MAP



GRAPHIC SCALE IN FEET  
1" = 200'

SOURCE: TOWN OF READING ZONING MAP DATED 04/27/2025 & TOWN OF READING MAPGEO

## PRIMROSE SCHOOLS FRANCHISING COMPANY PROPOSED CHILD DAY CARE FACILITY

PARCEL ID: 28-113  
885 MAIN STREET, TOWN OF READING  
MIDDLESEX COUNTY, MASSACHUSETTS



<b>DRAWN BY:</b>	SCL
<b>CHECKED BY:</b>	JHK
<b>DATE:</b>	02/27/2025
<b>SCALE:</b>	1" = 200'
<b>PROJECT ID:</b>	BOS-240115



**STONEFIELD**  
engineering & design

Rutherford, NJ · New York, NY · Salem, MA  
Princeton, NJ · Tampa, FL · Birmingham, MI  
www.stonefielddeng.com

120 Washington Street, Salem, MA 01970  
Phone 617.203.2076

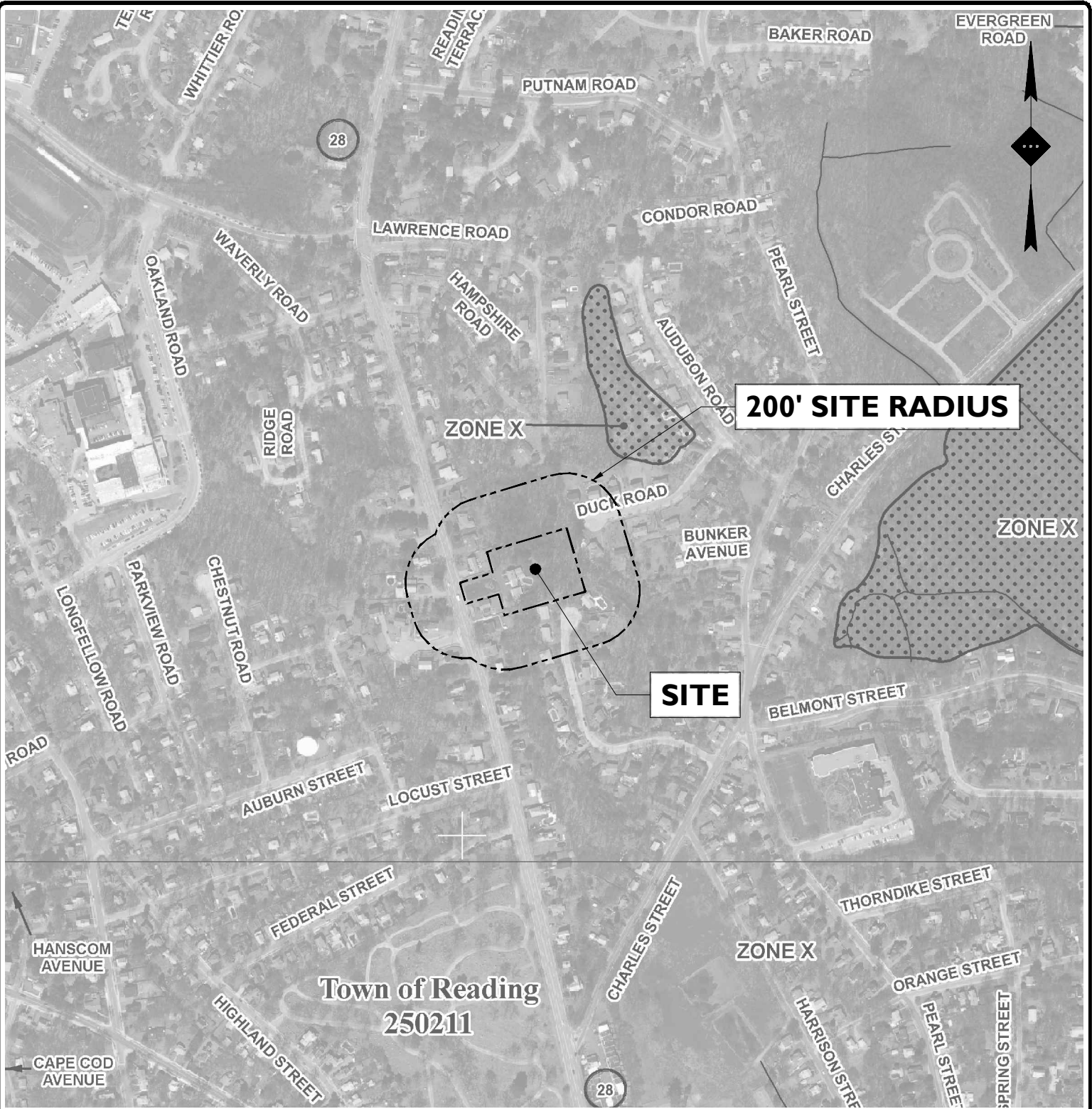

# FEMA FLOOD MAP

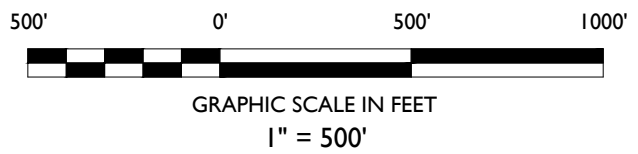

SOURCE: FEMA FLOOD MAP NUMBER 25017C0311E & 25017C0313E

**PRIMROSE SCHOOLS FRANCHISING COMPANY**  
**PROPOSED CHILD DAY CARE FACILITY**



PARCEL ID: 28-113  
 885 MAIN STREET, TOWN OF READING  
 MIDDLESEX COUNTY, MASSACHUSETTS

<b>DRAWN BY:</b>	SCL
<b>CHECKED BY:</b>	JHK
<b>DATE:</b>	02/27/2025
<b>SCALE:</b>	1" = 500'
<b>PROJECT ID:</b>	BOS-240115

**STONEFIELD**  
 engineering & design

Rutherford, NJ · New York, NY · Salem, MA  
 Princeton, NJ · Tampa, FL · Birmingham, MI  
[www.stonefielddeng.com](http://www.stonefielddeng.com)

120 Washington Street, Salem, MA 01970  
 Phone 617.203.2076

Z:\Boston\BOS\2024\BOS-240115 Primrose Schools - 885 Main Street, Reading, MA\CADD\Exhibit\Project Maps\2025-02-27 Project Maps.dwg

# **APPENDIX B**

## **SITE PLANS**

### **INVENTORY**

**B-1: SITE PLANS**

**B-2: STORMWATER MANAGEMENT PLAN**

**B-3: SOIL EROSION & SEDIMENT CONTROL PLANS**

**B-4: LANDSCAPING PLANS**

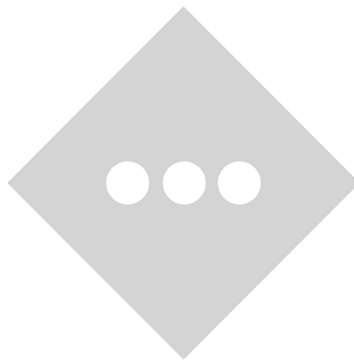

# **APPENDIX B-I**

## **SITE PLAN**

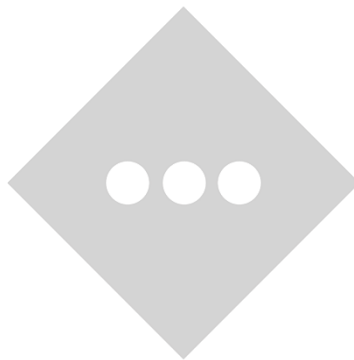



**APPENDIX B-2**  
**STORMWATER MANAGEMENT PLAN**

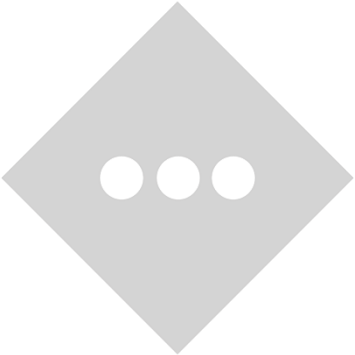

Z:\PROJECTS\2023\24015 PRIMOISE SCHOOLS - 881 MAIN STREET, MIDDLETOWN, MASSACHUSETTS

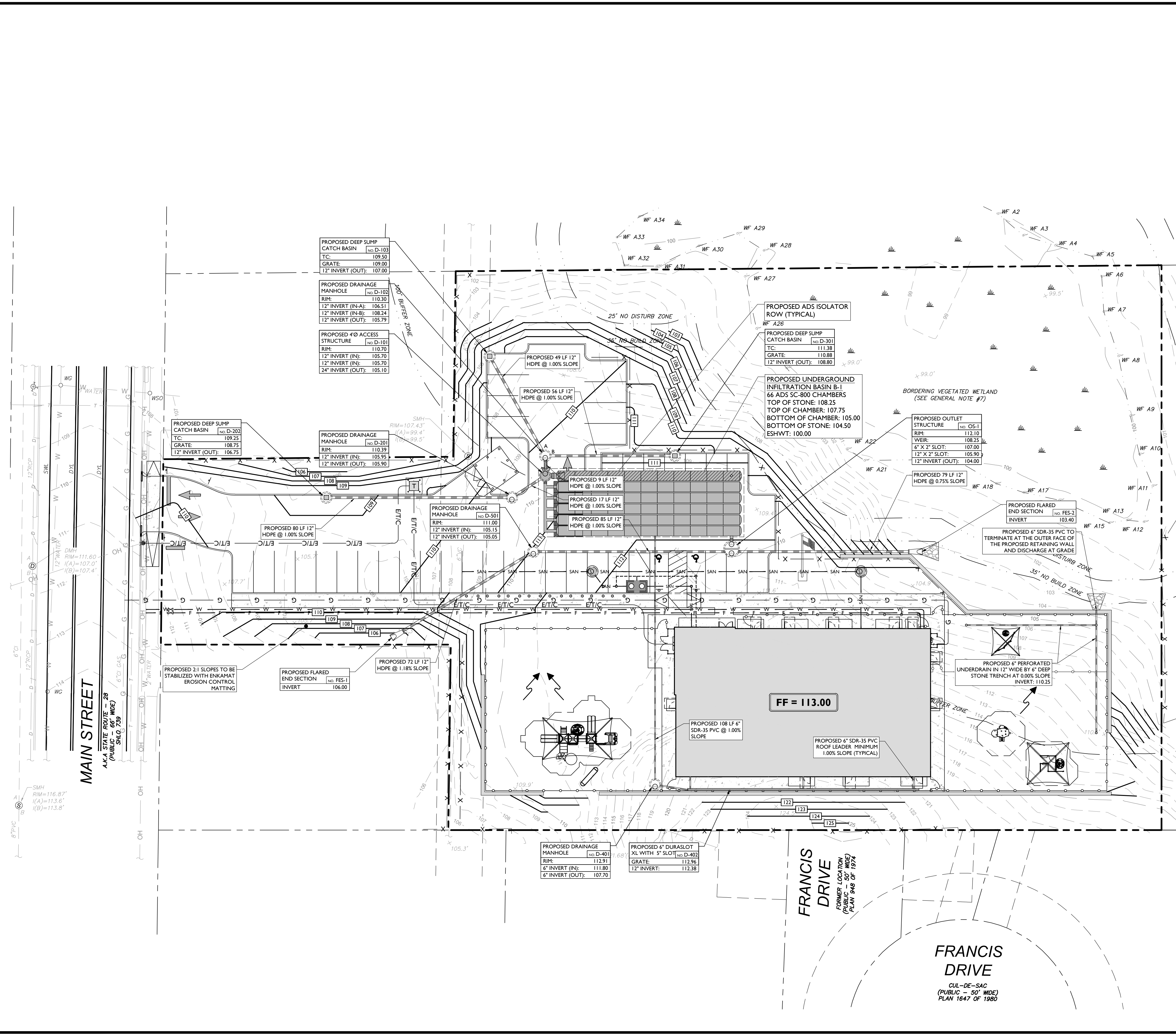

SYMBOL	DESCRIPTION
	PROPERTY LINE
	PROPOSED GRADING CONTOUR
	PROPOSED GRADING RIDGELINE
	PROPOSED STORMWATER STRUCTURES
	PROPOSED STORMWATER PIPING
	PROPOSED UNDERGROUND OUTLET STRUCTURE

**DRAINAGE AND UTILITY NOTES**

- THE CONTRACTOR TO PERFORM A TEST PIT PRIOR TO CONSTRUCTION (RECOMMEND 30 DAYS PRIOR) AT LOCATIONS OF EXISTING UTILITY CROSSINGS FOR STORMWATER IMPROVEMENTS. SHOULD A CONFLICT EXIST, THE CONTRACTOR SHALL IMMEDIATELY NOTIFY STONEFIELD ENGINEERING & DESIGN, LLC IN WRITING.
- CONTRACTOR SHALL START CONSTRUCTION OF STORM LINES AT THE LOWEST INVERT AND WORK UP-GRADE.
- THE CONTRACTOR IS REQUIRED TO CALL THE APPROPRIATE AUTHORITY FOR NOTICE OF CONSTRUCTION/EXCAVATION AND UTILITY MARK OUT PRIOR TO THE START OF CONSTRUCTION IN ACCORDANCE WITH STATE LAW. CONTRACTOR IS REQUIRED TO CONFIRM THE HORIZONTAL AND VERTICAL LOCATION OF UTILITIES IN THE FIELD. SHOULD A DISCREPANCY EXIST BETWEEN THE FIELD LOCATION OF A UTILITY AND THE LOCATION SHOWN ON THE PLAN SET OR SURVEY, THE CONTRACTOR SHALL NOTIFY STONEFIELD ENGINEERING & DESIGN, LLC IMMEDIATELY IN WRITING.
- THE CONTRACTOR IS RESPONSIBLE TO MAINTAIN A RECORD OF THE AS-BUILT LOCATIONS OF ALL PROPOSED UNDERGROUND STRUCTURE. THE CONTRACTOR SHALL NOTE ANY DISCREPANCIES BETWEEN THE AS-BUILT LOCATIONS AND THE LOCATIONS DEPICTED WITHIN THE PLAN SET. THIS RECORD SHALL BE PROVIDED TO THE OWNER FOLLOWING COMPLETION OF WORK.

**EXCAVATION, SOIL PREPARATION, AND DEWATERING NOTES**

- THE CONTRACTOR IS REQUIRED TO REVIEW THE REFERENCED GEOTECHNICAL DOCUMENTS PRIOR TO CONSTRUCTION, THESE DOCUMENTS SHALL BE CONSIDERED A PART OF THE PLAN SET.
- THE CONTRACTOR IS REQUIRED TO PREPARE SUBGRADE SOILS BENEATH ALL PROPOSED IMPROVEMENTS AND BACKFILL ALL EXCAVATIONS IN ACCORDANCE WITH RECOMMENDATIONS BY THE GEOTECHNICAL ENGINEER OF RECORD.
- THE CONTRACTOR IS RESPONSIBLE FOR PROVIDING SHORING FOR ALL EXCAVATIONS AS REQUIRED. CONTRACTOR SHALL HAVE THE SHORING DESIGN PREPARED BY A QUALIFIED PROFESSIONAL SHORING DESIGNER. THIS DESIGN SHALL BE SUBMITTED TO STONEFIELD ENGINEERING & DESIGN, LLC AND THE OWNER PRIOR TO THE START OF CONSTRUCTION.
- THE CONTRACTOR IS RESPONSIBLE FOR ENSURING THAT ALL OPEN EXCAVATIONS ARE PERFORMED AND PROTECTED IN ACCORDANCE WITH THE LATEST OSHA REGULATIONS.
- THE CONTRACTOR IS RESPONSIBLE FOR ANY DEWATERING DESIGN AND OPERATIONS, AS REQUIRED, TO CONSTRUCT THE PROPOSED IMPROVEMENTS. THE CONTRACTOR SHALL OBTAIN ANY REQUIRED PERMITS FOR DEWATERING OPERATIONS AND GROUNDWATER DISPOSAL.

**STORMWATER INFILTRATION BMP CONSTRUCTION NOTES**

- PRIOR TO THE START OF CONSTRUCTION, ANY AREA DESIGNATED TO BE USED FOR AN INFILTRATION BMP (E.G. BASIN, BIOTENTION AREA, ETC.) SHALL BE FENCED OFF AND SHALL NOT BE UTILIZED AS STORAGE FOR CONSTRUCTION EQUIPMENT OR AS A STOCKPILE AREA FOR CONSTRUCTION MATERIALS. NO ACTIVITY SHALL BE PERMITTED WITHIN THE INFILTRATION BASIN AREA UNLESS RELATED TO THE CONSTRUCTION OF THE INFILTRATION BASIN. IT IS THE RESPONSIBILITY OF THE CONTRACTOR TO NOTIFY ALL SUBCONTRACTORS OF BASIN AREA RESTRICTIONS.
- THE CONTRACTOR SHALL MAKE EVERY EFFORT, WHERE PRACTICAL, TO AVOID SUBGRADE SOIL COMPACTION IN THE AREAS DESIGNATED TO BE USED FOR AN INFILTRATION BMP.
- ALL EXCAVATION WITHIN THE LIMITS OF ANY INFILTRATION BMP SHALL BE PERFORMED WITH THE LIGHTEST PRACTICAL EXCAVATION EQUIPMENT. ALL EXCAVATION EQUIPMENT SHALL BE PLACED OUTSIDE THE LIMITS OF THE BASIN WHERE FEASIBLE. THE USE OF LIGHT-WEIGHT, RUBBER-TIRED EQUIPMENT (LESS THAN 8 PSI APPLIED TO THE GROUND SURFACE) IS RECOMMENDED WITHIN THE BASIN LIMITS.
- THE SEQUENCE OF SITE CONSTRUCTION SHALL BE COORDINATED WITH BASIN CONSTRUCTION TO ADHERE TO SEQUENCING LIMITATIONS.
- DURING THE FINAL GRADING OF AN INFILTRATION BASIN, THE BOTTOM OF THE BASIN SHALL BE DEEPLY TILLED WITH A ROTARY TILLER OR DISC HARROW AND THEN SMOOTHED OUT WITH A LEVELING DRAW OR EQUIVALENT GRADING EQUIPMENT. ALL GRADING EQUIPMENT SHALL BE LOCATED OUTSIDE OF THE BASIN BOTTOM WHERE FEASIBLE.
- FOLLOWING CONSTRUCTION OF AN INFILTRATION BASIN, SOIL INFILTRATION TESTING BY A LICENSED GEOTECHNICAL ENGINEER IS REQUIRED TO CERTIFY COMPLIANCE WITH THE DESIGN INFILTRATION RATES IN ACCORDANCE WITH APPENDIX E OF THE NEW JERSEY DEPARTMENT OF ENVIRONMENTAL PROTECTION'S BEST MANAGEMENT PRACTICES MANUAL, LATEST EDITION. IF THE FIELD INFILTRATION RATES ARE LOWER THAN THE RATE USED DURING DESIGN, THE CONTRACTOR SHALL NOTIFY STONEFIELD ENGINEERING & DESIGN, LLC IN WRITING IMMEDIATELY TO DETERMINE THE APPROPRIATE COURSE OF ACTION.
- THE CONTRACTOR SHALL NOTIFY THE MUNICIPALITY TO DETERMINE IF WITNESS TESTING IS REQUIRED DURING INFILTRATION BASIN EXCAVATION AND/OR SOIL INFILTRATION TESTING.

**STORMWATER UNDERGROUND BMP CONSTRUCTION NOTES**

- THE CONTRACTOR SHALL INSTALL AND BACKFILL THE UNDERGROUND BMP IN ACCORDANCE WITH THE MANUFACTURER'S SPECIFICATIONS.
- UNDERGROUND BASINS SHALL UTILIZE A STONE BACKFILL WITH A MINIMUM VOID RATIO OF 40%.
- NO CONSTRUCTION LOADING OVER UNDERGROUND BASINS IS PERMITTED UNTIL BACKFILL IS COMPLETE PER THE MANUFACTURER'S SPECIFICATIONS. NO VEHICLES SHALL BE STAGED OR OPERATE FROM A FIXED POSITION OVER THE BASIN.

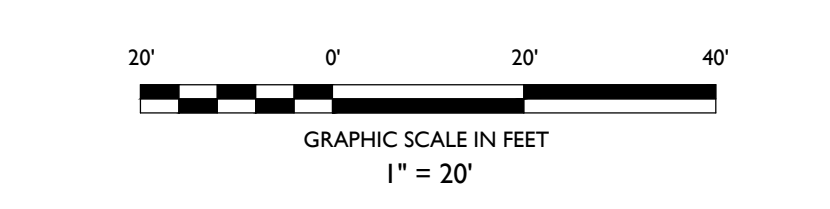

ISSUED FOR MUNICIPAL SUBMISSION	AID	BY
03/07/2025		
ISSUE	DATE	ISSUE
00		

NOT APPROVED FOR CONSTRUCTION

**STONEFIELD**  
engineering & design

Rutherford, NJ · New York, NY · Salem, MA  
Princeton, NJ · Tampa, FL · Birmingham, MI  
www.stonefielddesign.com

120 Washington Street, Suite 201, Salem, MA 01970  
Phone 617.203.2076

**LAND DEVELOPMENT PLANS**

**PRIMOISE SCHOOLS FRANCHISING COMPANY**

**PROPOSED CHILD DAY CARE FACILITY**

PARCEL ID: 28-113  
885 MAIN STREET  
TOWN OF READING  
MIDDLESEX COUNTY, MASSACHUSETTS

JOSHUA H. KLINE, P.E.  
MASSACHUSETTS LICENSE NO. 53936  
LICENSED PROFESSIONAL ENGINEER

**STONEFIELD**  
engineering & design

SCALE: 1" = 20' PROJECT ID: BOS-240115

TITLE:  
**STORMWATER MANAGEMENT PLAN**

DRAWING:  
**C-6**

**APPENDIX B-3**  
**SOIL EROSION & SEDIMENT CONTROL**  
**PLANS**

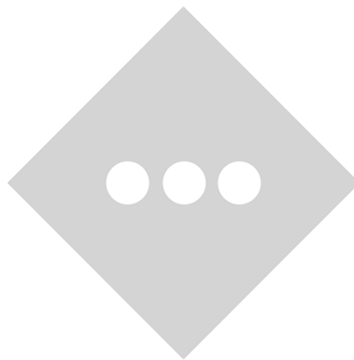

**STABILIZATION SPECIFICATIONS:**

I.A. TEMPORARY SEEDING AND MULCHING:  
GROUND LIMESTONE - APPLIED UNIFORMLY ACCORDING TO SOIL TEST RECOMMENDATIONS.  
FERTILIZER - APPLY 11 LBS./1,000 SF OF 10-20-10 OR EQUIVALENT WITH 50% WATER INSOLUBLE NITROGEN (UNLESS A SOIL TEST INDICATES OTHERWISE) WORKED INTO THE SOIL A MINIMUM OF 4".  
SEED - PERENNIAL RYEGRASS 100 LBS./ACRE (2.3 LBS./1,000 SF) OR OTHER APPROVED SEEDS; PLANT BETWEEN MARCH 1 AND MAY 15 OR BETWEEN AUGUST 15 AND OCTOBER 1.  
MULCH - UNROTTED STRAW OR HAY AT A RATE OF 70 TO 90 LBS./1,000 SF APPLIED TO ACHIEVE 95% SOIL SURFACE COVERAGE. MULCH SHALL BE ANCHORED BY APPROVED METHODS (I.E. PEG AND TWINE, MULCH NETTING, OR LIQUID MULCH BINDER).

I.B. PERMANENT SEEDING AND MULCHING:  
TOPSOIL - UNIFORM APPLICATION TO A DEPTH OF 5" (UNSETTLED).  
GROUND LIMESTONE - APPLIED UNIFORMLY ACCORDING TO SOIL TEST RECOMMENDATIONS.  
FERTILIZER - APPLY 11 LBS./1,000 SF OF 10-10-10 OR EQUIVALENT WITH 50% WATER INSOLUBLE NITROGEN (UNLESS A SOIL TEST INDICATES OTHERWISE) WORKED INTO THE SOIL A MINIMUM OF 4".  
SEED - TURF TYPE TALL FESCUE (BLEND OF 3 CULTIVARS) 350 LBS./ACRE (8 LBS./1,000 SF) OR OTHER APPROVED SEEDS; PLANT BETWEEN MARCH 1 AND OCTOBER 1 (SUMMER SEEDINGS REQUIRE IRRIGATION).  
MULCH - UNROTTED STRAW OR HAY AT A RATE OF 70 TO 90 LBS./1,000 SF APPLIED TO ACHIEVE 95% SOIL SURFACE COVERAGE. MULCH SHALL BE ANCHORED BY APPROVED METHODS (I.E. PEG AND TWINE, MULCH NETTING, OR LIQUID MULCH BINDER).

**DUST CONTROL NOTES**

- MULCHES - SEE STANDARD OF STABILIZATION WITH MULCHES ONLY, PG. 5-1
- VEGETATIVE COVER - SEE STANDARD FOR TEMPORARY VEGETATIVE COVER, PG. 7-1. PERMANENT VEGETATIVE COVER FOR SOIL STABILIZATION PG. 4-1 AND PERMANENT STABILIZATION WITH SOD, PG. 6-1
- SPRAY-ON ADHESIVES - ON MINERAL SOILS (NOT EFFECTIVE ON MUCK SOILS). KEEP TRAFFIC OFF THESE AREAS.
- TILLAGE - TO ROUGHEN SURFACE AND BRING CLODS TO THE SURFACE THIS IS A TEMPORARY EMERGENCY MEASURE WHICH SHOULD BE USED BEFORE SOIL BLOWING STARTS. BEGIN PLOWING ON WINDWARD SIDE OF SITE. CHISEL-TYPE PLOWS SPACED ABOUT 12 INCHES APART AND SPRING-TOOTHED HARROWS ARE EXAMPLES OF EQUIPMENT WHICH MAY PRODUCE THE DESIRED EFFECT.
- SPRINKLING - SITE IS SPRINKLED UNTIL THE SURFACE IS WET.
- BARRIERS - SOLID BOARD FENCES, SNOW FENCES, BURLAP FENCES, CRATE WALLS, BALES OF HAY AND SIMILAR MATERIAL CAN BE USED TO CONTROL AIR CURRENTS AND SOIL BLOWING.
- CALCIUM CHLORIDE - SHALL BE IN THE FORM OF LOOSE, DRY GRANULES OR FLAKES FINE ENOUGH TO FEED THROUGH COMMONLY USED SPREADERS AT A RATE THAT WILL KEEP SURFACE MOIST BUT NOT CAUSE POLLUTION OR PLANT DAMAGE. IF USED ON STEEPER SLOPES, THEN USE OTHER PRACTICES TO PREVENT WASHING INTO STREAMS OR ACCUMULATION AROUND PLANTS.
- STONE - COVER SURFACE WITH CRUSHED STONE OR COARSE GRAVEL.

**NRCS WEB SOIL SURVEY SOIL CHARACTERISTICS CHART**

TYPE OF SOIL	WHITMAN FINE SANDY LOAM (73B)	CHARLTON-URBAN LAND-HOLLIS COMPLEX (631C)	UDORHENT'S (655)	PAXTON FINE SANDY LOAM (305C)	CANTON-CHARLTON-URBAN LAND COMPLEX (629C)
PERCENT OF SITE COVERAGE	61.3%	28.5%	5.9%	3.8%	0.5%
HYDROLOGIC SOIL GROUP	D	A	D <sup>+</sup>	C	A
DEPTH TO RESTRICTIVE LAYER	7 TO 38 INCHES	> 80 INCHES	> 80 INCHES	20 TO 39 INCHES	18 TO 30 INCHES
SOIL PERMEABILITY	0.00 TO 0.14 IN / HR	0.60 TO 6.00 IN / HR	*	0.00 TO 0.14 IN / HR	2.00 TO 6.00 IN / HR
DEPTH TO WATER TABLE	0 TO 6 INCHES	> 80 INCHES	> 80 INCHES	18 TO 37 INCHES	> 80 INCHES

\* NOT SPECIFIED IN NRCS SOIL REPORT

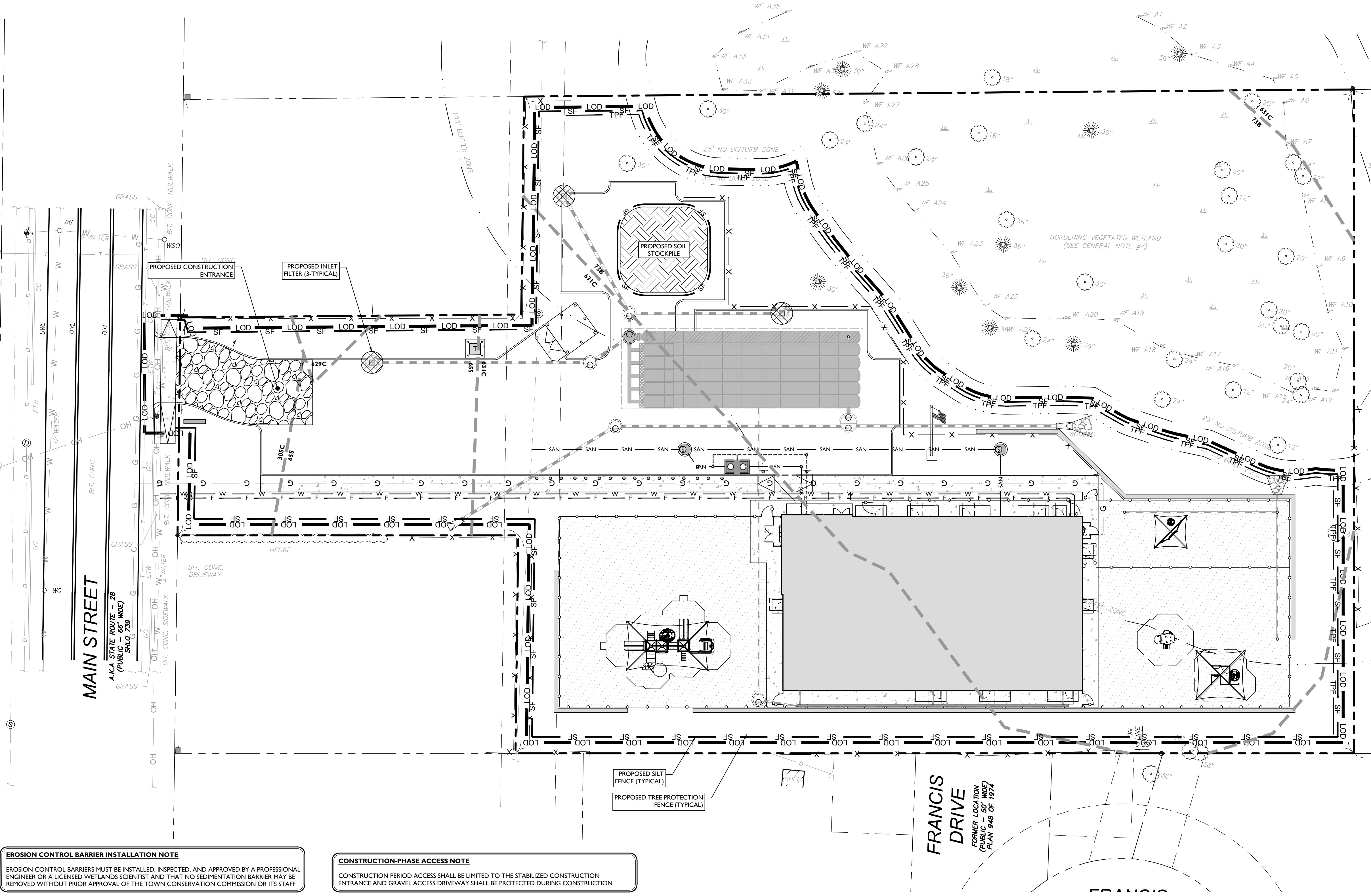

**SYMBOL DESCRIPTION**

	PROPERTY BOUNDARY
	ADJACENT PROPERTY BOUNDARY
	PROPOSED LIMIT OF DISTURBANCE
	PROPOSED SILT FENCE
	PROPOSED TREE PROTECTION FENCE
	PROPOSED STOCKPILE & EQUIPMENT STORAGE
	PROPOSED STABILIZED CONSTRUCTION ENTRANCE
	PROPOSED INLET PROTECTION FILTER

**SOIL EROSION AND SEDIMENT CONTROL NOTES**

- THE CONTRACTOR IS RESPONSIBLE FOR SOIL EROSION AND SEDIMENT CONTROL IN ACCORDANCE WITH LOCAL, STATE, AND FEDERAL REQUIREMENTS.
- THE CONTRACTOR IS RESPONSIBLE FOR DUST CONTROL IN COMPLIANCE WITH LOCAL, STATE, AND FEDERAL AIR QUALITY STANDARDS.
- THE CONTRACTOR IS RESPONSIBLE TO INSPECT ALL SOIL EROSION AND SEDIMENT CONTROL MEASURES WEEKLY AND AFTER A PRECIPITATION EVENT GREATER THAN 1 INCH. THE CONTRACTOR SHALL MAINTAIN AN INSPECTION LOG ON SITE AND DOCUMENT CORRECTIVE ACTION TAKEN THROUGHOUT THE COURSE OF CONSTRUCTION AS REQUIRED.

**SEQUENCE OF CONSTRUCTION**

- INSTALL CONSTRUCTION ENTRANCE (2 DAYS)
- STRIPPING AND CLEARING OF SITE (2 WEEKS)
- INSTALL CURBSIDE SEDIMENT BARRIERS (1 DAY)
- DEMOLISH EXISTING PAVEMENT WHERE APPLICABLE (7 DAYS)
- ROUGH GRADING AND TEMPORARY SEEDING (21 DAYS)
- BASE CONSTRUCTION INCLUDING STABILIZATION (14 DAYS)
- UTILITY CONSTRUCTION (10 DAYS)
- BUILDING CONSTRUCTION AND SITE IMPROVEMENTS (100 DAYS)
- FINAL GRADING (3 DAYS)
- SOIL RESTORATION MEASURES (3 DAYS)
- LANDSCAPING IMPROVEMENTS AND FINAL SEEDING & TOP SOILING (7 DAYS)
- REMOVE SOIL EROSION MEASURES (1 DAY)

NOTE: TIME DURATIONS ARE APPROXIMATE AND ARE INTENDED TO ACT AS A GENERAL GUIDE TO THE CONSTRUCTION TIMELINE. ALL DURATIONS ARE SUBJECT TO CHANGE BY CONTRACTOR. CONTRACTOR SHALL SUBMIT CONSTRUCTION SCHEDULE TO TOWNSHIP AND ENGINEER. CONTRACTOR SHALL PHASE CONSTRUCTION ACCORDINGLY.

**EROSION CONTROL BARRIER INSTALLATION NOTE**

EROSION CONTROL BARRIERS MUST BE INSTALLED, INSPECTED, AND APPROVED BY A PROFESSIONAL ENGINEER OR A LICENSED WETLANDS SCIENTIST AND THAT NO SEDIMENTATION BARRIER MAY BE REMOVED WITHOUT PRIOR APPROVAL OF THE TOWN CONSERVATION COMMISSION OR ITS STAFF

**CONSTRUCTION-PHASE ACCESS NOTE**

CONSTRUCTION PERIOD ACCESS SHALL BE LIMITED TO THE STABILIZED CONSTRUCTION ENTRANCE AND GRAVEL ACCESS DRIVEWAY SHALL BE PROTECTED DURING CONSTRUCTION.

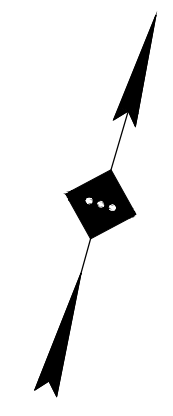

Know what's below  
Call before you dig.

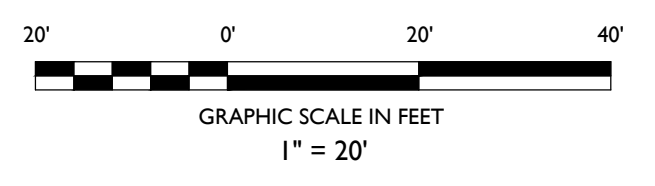

ISSUED FOR MUNICIPAL SUBMISSION	AID	BY
03/07/2025		
00		

NOT APPROVED FOR CONSTRUCTION

**STONEFIELD**  
engineering & design

Rutherford, NJ · New York, NY · Salem, MA  
Princeton, NJ · Tampa, FL · Birmingham, MI  
www.stonefielddesign.com

120 Washington Street, Suite 201, Salem, MA 01970  
Phone 617.203.2076

LAND DEVELOPMENT PLANS

**PRIMROSE SCHOOLS**  
**FRANCHISING COMPANY**

PROPOSED CHILD DAY CARE FACILITY

PARCEL ID: 28-113  
885 MAIN STREET  
TOWN OF READING  
MIDDLESEX COUNTY, MASSACHUSETTS

JOSHUA H. KLINE, P.E.  
MASSACHUSETTS LICENSE No. 53936  
LICENSED PROFESSIONAL ENGINEER

**STONEFIELD**  
engineering & design

SCALE: 1" = 20' PROJECT ID: BOS-240115

TITLE: **SOIL EROSION & SEDIMENT CONTROL PLAN**

DRAWING: **C-9**

# **APPENDIX B-4**

## **LANDSCAPING PLANS**

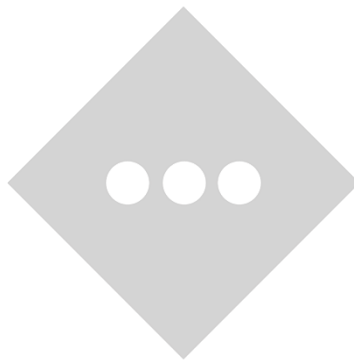

PLANT SCHEDULE							
SYMBOL	CODE	QTY	BOTANICAL NAME	COMMON NAME	SIZE	CONTAINER	REMARKS
DECIDUOUS TREES							
	LIQ	2	LIQUIDAMBAR STYRACIFLUA	SWEET GUM	3" - 3.5" CAL	B&B	RECOMMENDED NATIVE PLANT
	MAG	2	MAGNOLIA VIRGINIANA	SWEETBAY MAGNOLIA	3" - 3.5" CAL	B&B	RECOMMENDED NATIVE PLANT
	NYS	4	NYSSA SYLVATICA	TUPELO	3" - 3.5" CAL	B&B	RECOMMENDED NATIVE PLANT
	PAL	4	QUERCUS PALUSTRIS	PIN OAK	3" - 3.5" CAL	B&B	RECOMMENDED NATIVE PLANT
	TIL	1	TILIA AMERICANA	AMERICAN LINDEN	3" - 3.5" CAL	B&B	RECOMMENDED NATIVE PLANT
EVERGREEN TREES							
	VIR	37	JUNIPERUS VIRGINIANA	EASTERN REDCEDAR	6" - 8" HT	B&B	RECOMMENDED NATIVE PLANT
	JUN	12	JUNIPERUS VIRGINIANA 'N. SELECT GREEN'	EMERALD FEATHER EASTERN REDCEDAR	6" - 8" HT	B&B	RECOMMENDED NATIVE PLANT
	PIC	12	PICEA GLAUCA	WHITE SPRUCE	6" - 8" HT	B&B	RECOMMENDED NATIVE PLANT
SHRUBS							
	COR	10	CORNUS STOLONIFERA 'FARKOW'	ARCTIC FIRE RED TWIG DOGWOOD	18" - 24"	POT	
	PHY	6	PHYSOCARPUS OPULIFOLIUS 'LITTLE DEVIL'	LITTLE DEVIL DWARF NINEBARK	18" - 24"	POT	
	VIB	8	VIBURNUM DENTATUM	VIBURNUM	18" - 24"	POT	RECOMMENDED NATIVE PLANT
EVERGREEN SHRUBS							
	GLA	29	ILEX GLABRA 'COMPACTA'	COMPACT INKBERRY	18" - 24"	POT	RECOMMENDED NATIVE PLANT
	TAX	10	TAXUS MEDIA 'DENSIFORMIS'	DENSE ANGLO-JAPANESE YEW	18" - 24"	POT	
GROUND COVERS							
	CAR	62	CAREX PENNSYLVANICA	PENNSYLVANIA SEDGE	1 GAL.	POT, 24" O.C.	RECOMMENDED NATIVE PLANT
	BAR	46	JUNIPERUS HORIZONTALIS 'BAR HARBOR'	BAR HARBOR CREEPING JUNIPER	1 GAL.	POT, 36" O.C.	
PERENNIALS AND GRASSES							
	ROS	59	COREOPSIS ROSEA	ROSE COREOPSIS	1 GAL.	POT, 24" O.C.	RECOMMENDED NATIVE PLANT
	HEM	17	HEMEROCALLIS X 'STELLA DE ORO'	STELLA DE ORO DAYLILY	1 GAL.	POT, 24" O.C.	
	PAN	11	PANICUM VIRGATUM 'SHENANDOAH'	SHENANDOAH SWITCH GRASS	1 GAL.	POT, 24" O.C.	RECOMMENDED NATIVE PLANT

NOTE: IF ANY DISCREPANCIES OCCUR BETWEEN AMOUNTS SHOWN ON THE LANDSCAPE PLAN AND WITHIN THE PLANT LIST, THE PLAN SHALL DICTATE.

MAINTENANCE TASK	WINTER			SPRING			SUMMER			FALL					
	DEC	JAN	FEB	MAR	APR	MAY	FREQUENCY	JUN	JUL	AUG	FREQUENCY	SEP	OCT	NOV	FREQUENCY
SITE INSPECTION				X	X	X	ONCE PER SEASON	X	X	X	ONCE PER SEASON	X	X	X	ONCE PER SEASON
DEBRIS & WEED CONTROL				X	X	X	BI-WEEKLY	X	X	X	BI-WEEKLY	X	X	X	BI-WEEKLY
IRRIGATION MAINTENANCE				X	X	X	ONCE PER SEASON				N/A		X		ONCE PER SEASON
MULCHING				X	X	X	ONCE PER SEASON				N/A		X		N/A
SEASONAL PLANTINGS				X	X	X	ONCE PER SEASON	X	X	X	WEEKLY	X	X	X	WEEKLY
MOWING OF TURF				X	X	X	WEEKLY	X	X	X	WEEKLY	X	X	X	WEEKLY
MOWING OF WILDFLOWERS				X	X	X	N/A				N/A		X		ONCE PER SEASON
PRUNING				X	X	X	MONTHLY				N/A		X		ONCE PER SEASON
FERTILIZER & AMENDMENTS				X	X	X	MONTHLY	X	X	X	BI-WEEKLY	X	X	X	BI-WEEKLY
INSECT & DISEASE CONTROL				X	X	X	ONCE PER SEASON	X	X	X	BI-WEEKLY	X	X	X	N/A
PLANTING RENOVATION				X	X	X	ONCE PER SEASON				N/A		X		ONCE PER SEASON
LANDSCAPE STRUCTURES INSPECTION				X	X	X	ONCE PER SEASON				N/A		X		N/A
LIGHTING MAINTENANCE				X	X	X	ONCE PER SEASON				N/A		X		ONCE PER SEASON
PAVED SURFACE MAINTENANCE				X	X	X	ONCE PER SEASON				N/A		X		N/A

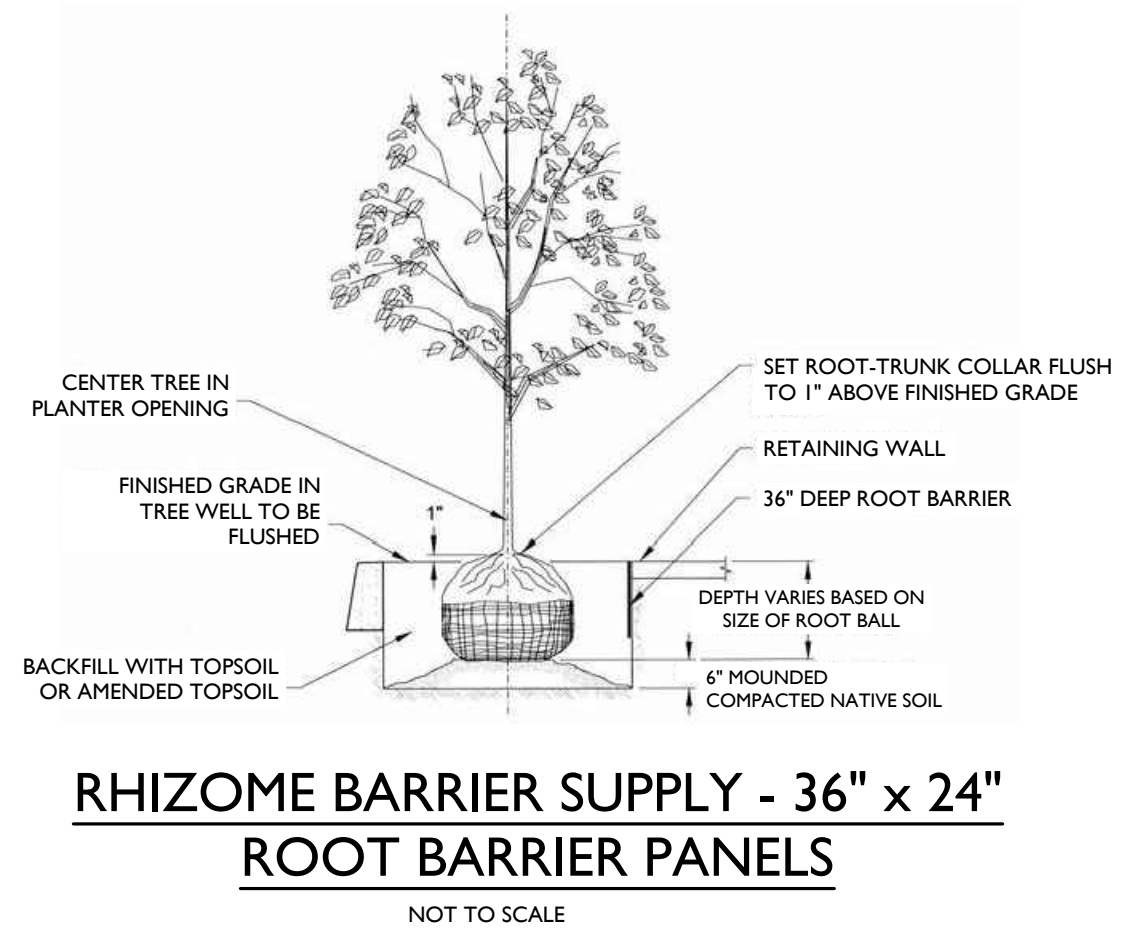

RHIZOME BARRIER SUPPLY - 36" x 24" ROOT BARRIER PANELS  
NOT TO SCALE

SYMBOL	DESCRIPTION
	PROPOSED ROOT BARRIER
	PROPOSED STREET TREES
	PROPOSED REPLACEMENT TREES

LANDSCAPING REQUIREMENTS		
CODE SECTION	REQUIRED	PROPOSED
§ 6.5.2	LANDSCAPE STANDARDS SIDE YARD SETBACKS SHALL BE PLANTED WITH GRASS, SHRUBS AND SHADE TREES	COMPLIES
§ 6.5.7	STREET TREES 1 TREE FOR EVERY 50 LF OF FRONTAGE (55 FT) * (1 TREE / 50 FT FRONTAGE) = 1 TREE	1 TREE

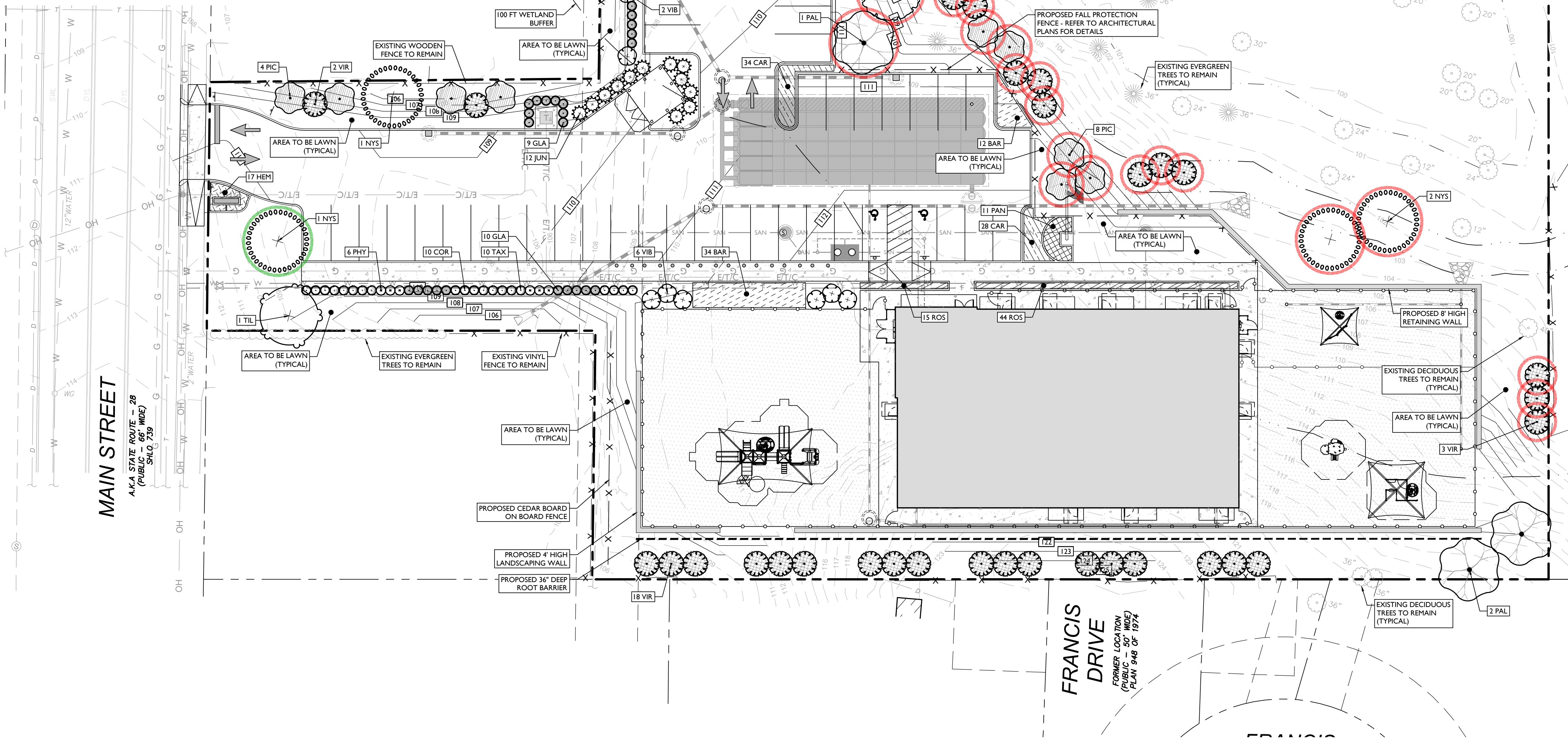

Know what's below  
Call before you dig.

**IRRIGATION NOTE:**  
IRRIGATION CONTRACTOR TO PROVIDE A DESIGN FOR AN IRRIGATION SYSTEM SEPARATING PLANTING BEDS FROM LAWN AREA. PRIOR TO CONSTRUCTION, DESIGN IS TO BE SUBMITTED TO THE PROJECT LANDSCAPE DESIGNER FOR REVIEW AND APPROVAL. WHERE POSSIBLE, DRIP IRRIGATION AND OTHER WATER CONSERVATION TECHNIQUES SUCH AS RAIN SENSORS SHALL BE IMPLEMENTED. CONTRACTOR TO VERIFY MAXIMUM ON SITE DYNAMIC WATER PRESSURE AVAILABLE MEASURED IN PSI. PRESSURE REDUCING DEVICES OR BOOSTER PUMPS SHALL BE PROVIDED TO MEET SYSTEM PRESSURE REQUIREMENTS. DESIGN TO SHOW ALL VALVES, PIPING, HEADS, BACKFLOW PREVENTION, METERS, CONTROLLERS, AND SLEEVES WITHIN HARDSCAPE AREAS.

**LANDSCAPING NOTES**

- THE CONTRACTOR SHALL RESTORE ALL DISTURBED GRASS AND LANDSCAPED AREAS TO MATCH EXISTING CONDITIONS UNLESS INDICATED OTHERWISE WITHIN THE PLAN SET.
- THE CONTRACTOR SHALL RESTORE ALL DISTURBED LAWN AREAS WITH A MINIMUM 4 INCH LAYER OF TOPSOIL AND SEED.
- THE CONTRACTOR SHALL RESTORE MULCH AREAS WITH A MINIMUM 3 INCH LAYER OF MULCH.
- THE MAXIMUM SLOPE ALLOWABLE IN LANDSCAPE RESTORATION AREAS SHALL BE 3 FEET HORIZONTAL TO 1 FOOT VERTICAL (3:1 SLOPE) UNLESS INDICATED OTHERWISE WITHIN THE PLAN SET.
- THE CONTRACTOR IS REQUIRED TO LOCATE ALL SPRINKLER HEADS IN AREA OF LANDSCAPING DISTURBANCE PRIOR TO CONSTRUCTION. THE CONTRACTOR SHALL RELOCATE SPRINKLER HEADS AND LINES IN ACCORDANCE WITH OWNER'S DIRECTION WITHIN AREAS OF DISTURBANCE.
- THE CONTRACTOR SHALL ENSURE THAT ALL DISTURBED LANDSCAPED AREAS ARE GRADED TO MEET FLUSH AT THE ELEVATION OF WALKWAYS AND TOP OF CURB ELEVATIONS EXCEPT UNLESS INDICATED OTHERWISE WITHIN THE PLAN SET. NO ABRUPT CHANGES IN GRADE ARE PERMITTED IN DISTURBED LANDSCAPING AREAS.

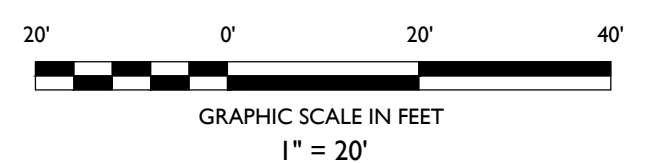

ISSUED FOR MUNICIPAL SUBMISSION	DATE	BY
00	03/07/2025	

NOT APPROVED FOR CONSTRUCTION

**STONEFIELD**  
engineering & design

Rutherford, NJ • New York, NY • Salem, MA  
Princeton, NJ • Tampa, FL • Birmingham, MI  
www.stonefielddesign.com

120 Washington Street, Suite 201, Salem, MA 01970  
Phone 617.203.2076

LAND DEVELOPMENT PLANS

**PRIMROSE SCHOOLS FRANCHISING COMPANY**

PROPOSED CHILD DAY CARE FACILITY

PARCEL ID: 28-113  
885 MAIN STREET  
MIDDLESEX COUNTY, MASSACHUSETTS

JOSHUA H. KLINE, P.E.  
MASSACHUSETTS LICENSE No. 53936  
LICENSED PROFESSIONAL ENGINEER

**STONEFIELD**  
engineering & design

SCALE: 1" = 20' PROJECT ID: BOS-240115

TITLE:  
**LANDSCAPING PLAN**

DRAWING:  
**C-10**

**APPENDIX C**  
**STORMWATER BMP LOCATION EXHIBIT**

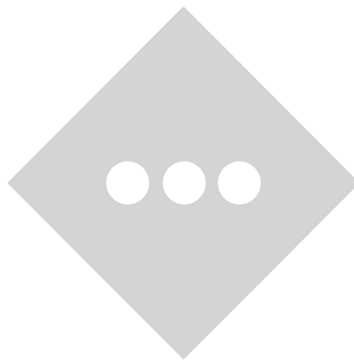

Z:\PROJECTS\2023\240115 PRIMROSE SCHOOLS - 885 MAIN STREET, MIDDLETOWN, MASSACHUSETTS\DWG\240115\_01.DWG, 11/15/2023, 10:42 AM, JKH/MLT/DWG

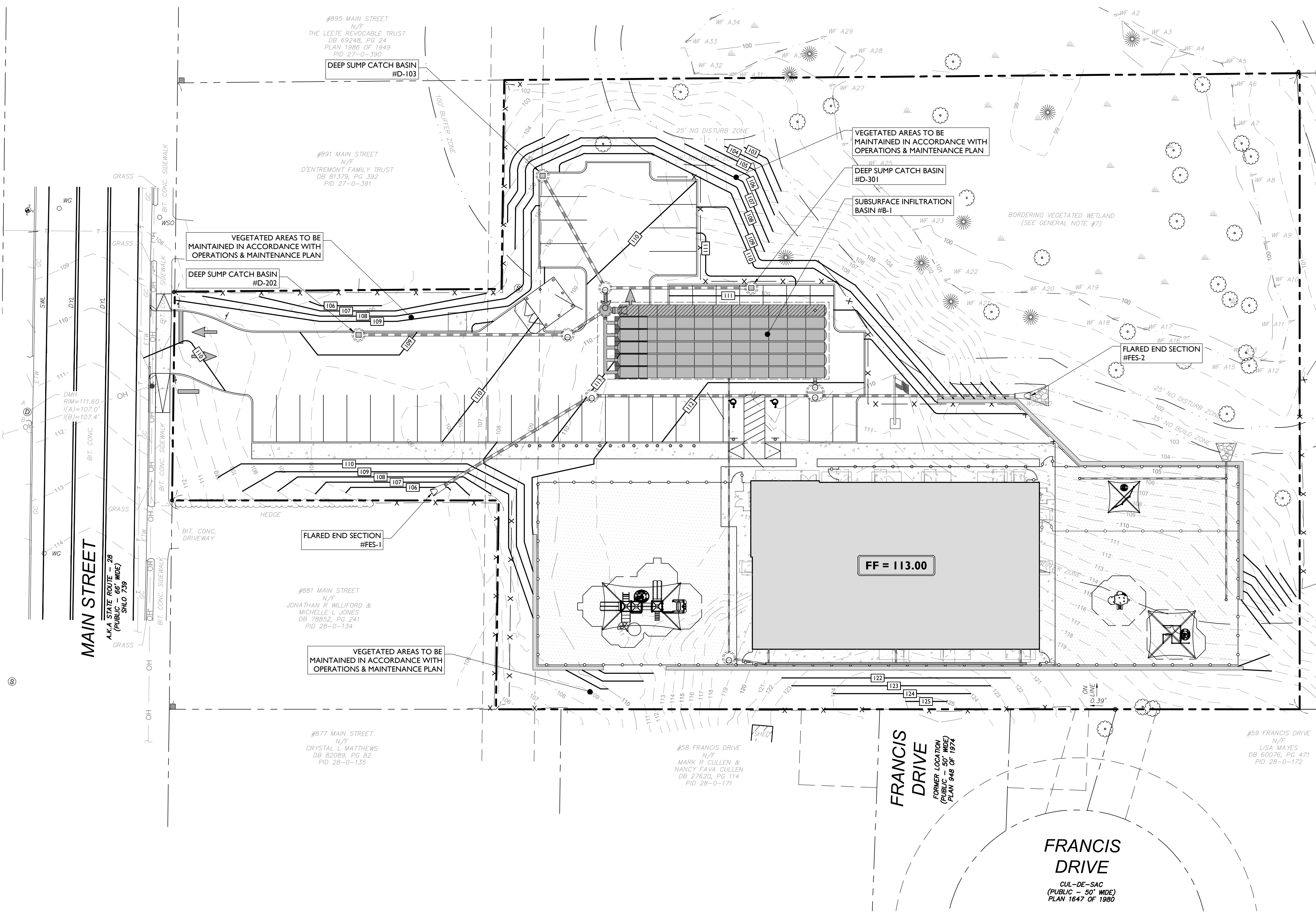

SYMBOL	DESCRIPTION
	PROPERTY LINE
	ADJACENT PROPERTY LINE
	EXISTING DRAINAGE AREA
	TIME OF CONCENTRATION PATH
	EXISTING GRASS AREA
	EXISTING WOODED AREA

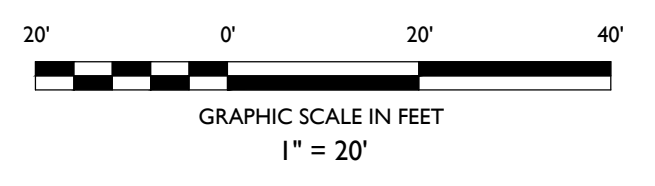
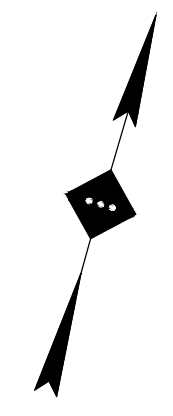

DATE	ISSUE	BY	DESCRIPTION
03/07/2023	AD		FOR MUNICIPAL SUBMISSION

**NOT APPROVED FOR CONSTRUCTION**

**STONEFIELD**  
engineering & design

Rutherford, NJ • New York, NY • Boston, MA  
Princeton, NJ • Tampa, FL • Detroit, MI  
www.stonefielddesign.com

1 Beacon Street, 15 Floor, Boston, MA 02108  
Phone 617.203.2076

**ADA ARCHITECTS**

**PROP PRIMROSE SCHOOL  
CHILD CARE CENTER**

PARCEL ID: 28-113  
885 MAIN STREET  
TOWN OF READING  
MIDDLESEX COUNTY, MASSACHUSETTS

JOSHUA H. KLINE, P.E.  
MASSACHUSETTS LICENSE No. 53936  
LICENSED PROFESSIONAL ENGINEER

**STONEFIELD**  
engineering & design

SCALE: 1" = 20' PROJECT ID: BOS-240115

TITLE:  
**BMP LOCATION EXHIBIT**

DRAWING:  
**I OF I**

# **APPENDIX D**

## **STORMTECH ISOLATOR ROW**

### **MANUFACTURER SPECIFICATIONS**

#### **INVENTORY**

**D-1: STORMTECH SC-800 FIELD GUIDE**

**D-2: STORMTECH ISOLATOR ROW PLUS MANUAL**

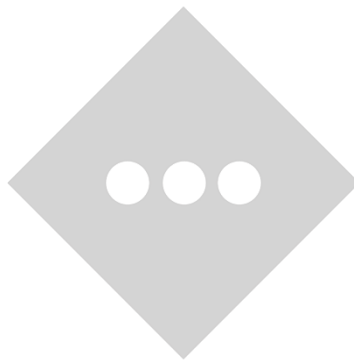

# **APPENDIX D-I**

## **STORMTECH SC-800 FIELD GUIDE**

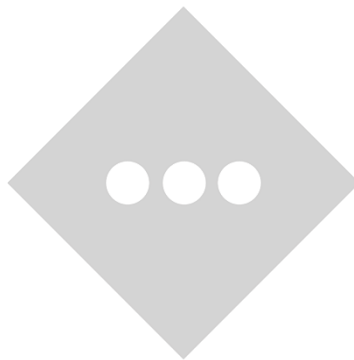

# SC-160LP, SC-310, SC-740, DC-780 & SC-800 Design Manual

StormTech® Chamber Systems for Stormwater Management





# 1.0 Introduction

## 1.1 Introduction

StormTech stormwater management systems allow storm water professionals to create more profitable, environmentally sound developments. Compared with other subsurface systems, StormTech systems offer lower overall installed cost, superior design flexibility and enhanced performance. Applications include commercial, residential, agricultural and highway drainage.

StormTech has invested millions of dollars and many years in the development of StormTech chambers. These innovative products exceed the rigorous requirements of the standards governing the design of thermoplastic structures.

## 1.2 Gold Standard in Stormwater Management

The advanced designs of StormTech chambers were created by implementing an aggressive research, development, design and manufacturing protocol. StormTech chamber products establish the new gold standard in stormwater management through:

- Collaborations with experts in the field of buried plastic structures and polyolefin materials
- The development and utilization of new testing methods and proprietary test methods
- The use of thermoformed prototypes to verify engineering models, perform in-ground testing and install observation sites
- The investment in custom-designed, injection molding equipment
- The utilization of polypropylene and polyethylene as manufacturing materials
- The design of molded-in features not possible with traditional thermoformed chambers

Section 3.0 of this design manual, Structural Capabilities, provides a detailed description of the research, development and design process.

Many of StormTech's unique chamber features can benefit a site developer, stormwater system designer, and installer. Where applicable, StormTech Product Specifications are referenced throughout this design manual. If StormTech's unique product benefits are important to a stormwater system design, consider including the applicable StormTech Product Specifications on the site plans. This can prevent substitutions with inferior products. Refer to Section 14.0, *StormTech Product Specifications*.

## 1.3 Product Quality and Design to International Standards

StormTech chambers are designed to meet the full scope of design requirements of Section 12.12 of the AASHTO LRFD Bridge Design Specifications and produced to the requirements of the American

Society of Testing Materials (ASTM) International specifications F2418 (polypropylene chambers) and F2922 (polyethylene chambers).

StormTech chambers provide the full AASHTO safety factors for live loads and permanent earth loads. The two ASTM standards mentioned previously are linked to the AASHTO LRFD Bridge Design Specifications Section 12.12 design standard. Both ASTM standards require that the safety factors included in the AASHTO guidance are achieved as a prerequisite to meeting either ASTM F2418 or ASTM F2922. StormTech chambers are also designed in accordance with ASTM F2787, Standard Practice for Structural Design of Thermoplastic Corrugated Wall Stormwater Collection Chambers which provides specific guidance on how to design thermoplastic chambers in accordance with AASHTO Section 12.12. These standards provide both the assurance of product quality and safe structural design.

For non-proprietary specifications for public bids that ensure high product quality and safe design, consider including the specification in Section 15.0 Chamber Specifications for Contract Documents.

## 1.4 Technical Support for Plan Reviews

ADS's engineering staff is available to review proposed plans that incorporate StormTech chamber systems. They are also available to assist with plan conversions from existing products to StormTech. Not all plan sheets are necessary for StormTech's review. Required sheets include plan view sheet(s) with design contours, cross sections of the stormwater system including catch basins and drainage details.

When specifying StormTech chambers it is recommended that the following items are included in project plans: StormTech chamber system General Notes, applicable StormTech chamber illustrations and StormTech chamber system Product Specifications. These items are available in various formats and can be obtained by contacting StormTech at **800-821-6710** or may be downloaded at **adspipe.com**.

StormTech's plan review is limited to the sole purpose of determining whether plans meet StormTech chamber systems' minimum requirements. **It is the ultimate responsibility of the design engineer to assure that the stormwater system's design is in full compliance with all applicable laws and regulations.** StormTech products must be designed and installed in accordance with StormTech's minimum requirements.

**Email plans to:**  
info@adspipe.com.

## 2.0 Product Information

### 2.1 Product Applications

StormTech chamber systems may function as stormwater detention, retention, first-flush storage, or some combination of these. The StormTech chambers can be used for commercial, municipal, industrial, recreational, and residential applications especially for installations under parking lots and commercial roadways.

One of the key advantages of the StormTech chamber system is its design flexibility. Chambers may be configured into beds or trenches of various sizes or shapes. They can be centralized or decentralized, and fit on nearly all sites. Chamber lengths enhance the ability to develop on both existing and pre-developed projects. The systems can be designed easily and efficiently around utilities, natural or man-made structures and any other limiting boundaries.

### 2.2 Chambers for Stormwater Detention

Chamber systems have been used effectively for storm water detention for over 20 years. A detention system temporarily holds water while it is released at a defined rate through an outlet. While some infiltration may occur in a detention system, it is often considered an environmental benefit and a storage safety factor. Over 70% of StormTech's installations are non-watertight detention systems. There are only a few uncommon situations where a detention system might need to limit infiltration: the subgrade soil's bearing capacity is significantly affected by saturation such as with expansive clays or karst soils, and; in sensitive aquifer areas where the depth to groundwater does not meet local guidelines. Adequate pretreatment could eliminate concerns for the latter case. A thermoplastic liner may be considered for both situations to limit infiltration.

### 2.3 Stone Porosity Assumption

A StormTech chamber system requires the application of clean, crushed, angular stone below, between and above the chambers. This stone serves as a structural component while allowing conveyance and storage of stormwater. Storage volume examples throughout this Design Manual are calculated with an assumption that the stone has an industry standard porosity of 40%. Actual stone porosity may vary. Contact StormTech for information on calculating storm water volumes with varying stone porosity assumptions.

### 2.4 Chamber Selection

Primary considerations when selecting between the SC-160LP, SC-310, SC-740, DC-780 & SC-800 chambers are the depth to restrictive layer, available area for subsurface storage, cover height and outfall restrictions.



**StormTech systems can be integrated into retrofit and new construction projects.**

The StormTech SC-160LP chamber shown on page 4 is the smallest of the chamber family and has been optimized to fit in the shallowest of applications. This extra low profile chamber allows for storage of 1.01 ft<sup>3</sup>/ft<sup>2</sup> (0.3m<sup>3</sup>/m<sup>2</sup>) [minimum] of storage.

The StormTech SC-310 chamber shown on page 6 is ideal for systems requiring low-rise and wide-span solutions. This low profile chamber allows the storage of large volumes, 1.3 ft<sup>3</sup>/ft<sup>2</sup> (0.40 m<sup>3</sup>/m<sup>2</sup>) [minimum], at minimum depths.

Like the Stormtech SC-310, the StormTech SC-310-3 found on page 8 allows for a design option for sites with both limited cover and limited space. With only 3 of spacing between the chambers, the SC-310-3 still provides 1.3 ft<sup>3</sup>/ft<sup>2</sup> (0.40 m<sup>3</sup>/m<sup>2</sup>) [minimum] of storage.

The StormTech SC-740 chamber shown on page 10 optimizes storage volumes in relatively small footprints. By providing 2.2 ft<sup>3</sup>/ft<sup>2</sup> (0.67 m<sup>3</sup>/m<sup>2</sup>) [minimum] of storage, the SC-740 chambers can minimize excavation, backfill and associated costs.

The DC-780 chamber shown on page 12 has been developed for those applications which exceed the maximum 8 ft (2.44 m) burial depth of the SC-740 and SC-310 chambers. The DC-780 is a modified version of the SC-740 allowing it to reach a maximum burial depth of 12 ft (3.66 m). The design of the DC-780 chamber, like other StormTech chambers, is designed and manufactured in accordance with the AASHTO LRFD Bridge Design Specifications as well as ASTM F 2418 and ASTM F 2787 ensuring structural adequacy for deeper systems.

StormTech SC-800 improves upon the SC-740 adding more storage in the same vertical depth. The SC-800 is 3 inches taller than the SC-740 but only requires 15" of cover (measured to bottom of flexible pavement / top of rigid pavement). Developed for applications where depth available depth space are limited.

The end corrugations of the DC-780 chamber have not been modified in order to allow connections to the SC-740 chamber. This will allow hybrid systems utilizing both chambers in one system design.

# SC-800 Chamber

Designed to meet the most stringent industry performance standards for superior structural integrity while providing designers with a cost-effective method to save valuable land and protect water resources. The StormTech system is designed primarily to be used under parking lots, thus maximizing land usage for private (commercial) and public applications. StormTech chambers can also be used in conjunction with Green Infrastructure, thus enhancing the performance and extending the service life of these practices.

## StormTech SC-800 Chamber (not to scale)

### Nominal Specifications

Size (L x W x H)	85.4" x 51" x 33" (2169 x 1295 x 838 mm)
Chamber Storage	50.6 ft <sup>3</sup> (1.43 m <sup>3</sup> )
Min. Installed Storage*	81.0 ft <sup>3</sup> (2.29 m <sup>3</sup> )
Weight	81.8 lbs (37.1 kg)

\*Assumes 6" (150 mm) stone above, below and between chambers and 40% stone porosity.



## Shipping

30 chambers/pallet

60 end caps/pallet

12 pallets/truck

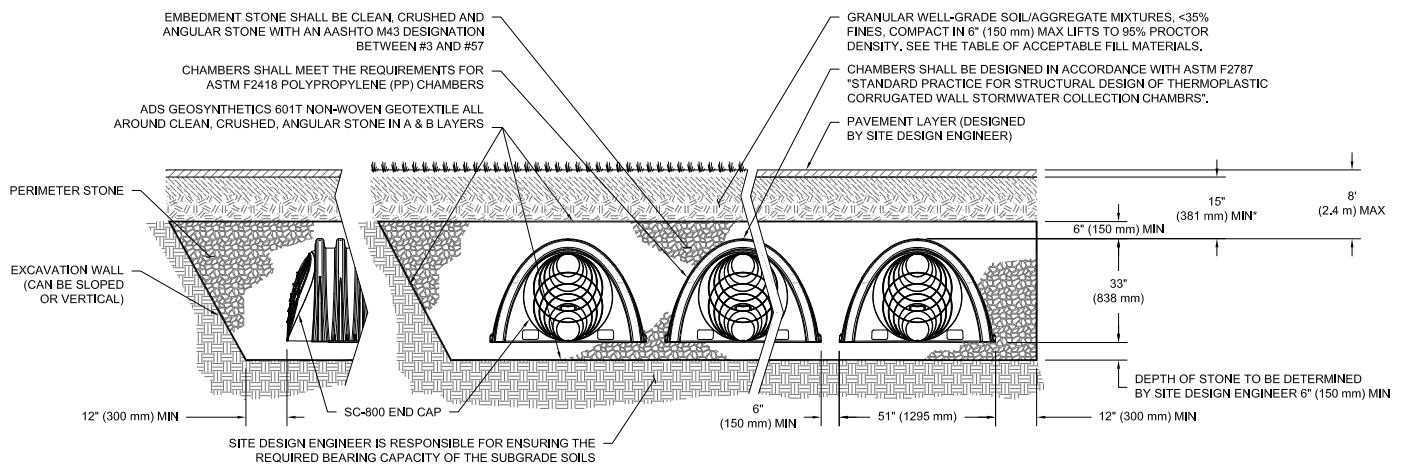
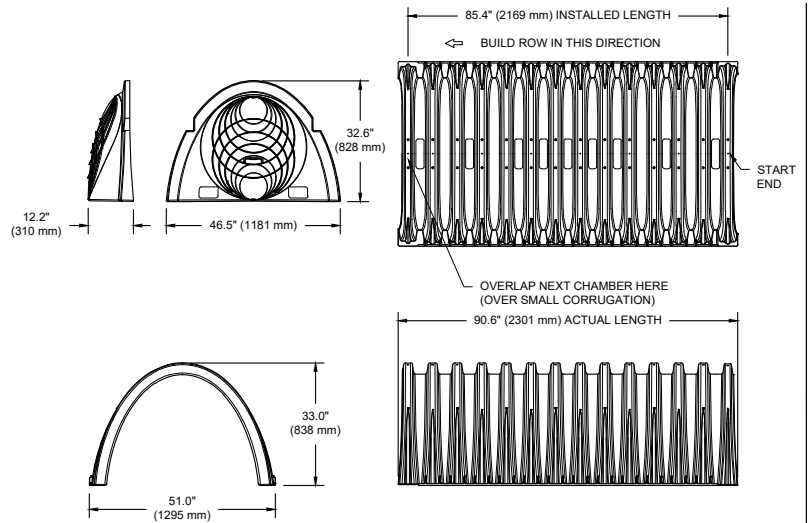

\*MINIMUM COVER TO BOTTOM OF FLEXIBLE PAVEMENT, FOR UNPAVED INSTALLATIONS WHERE RUTTING FROM VEHICLES MAY OCCUR, INCREASE COVER TO 21" (533 mm).

The installed chamber system shall provide the load factors specified in the AASHTO LRFD bridge design specifications section 12.12 for earth and live loads, with consideration for impact and multiple vehicle presences.

### Cumulative Storage Volumes Per Chamber

Assumes 40% Stone Porosity. Calculations are Based Upon a 6" (150 mm) Stone Base Under Chambers.

Depth of Water in System Inches (mm)	Cumulative Chamber Storage ft <sup>3</sup> (m <sup>3</sup> )	Total System Cumulative Storage ft <sup>3</sup> (m <sup>3</sup> )
45 (1143)	↑ 50.62 (1.433)	81.08 (2.296)
44 (1118)	50.62 (1.433)	79.96 (2.264)
43 (1092)	Stone 50.62 (1.433)	78.83 (2.232)
42 (1067)	Cover 50.62 (1.433)	77.70 (2.200)
41 (1041)	↓ 50.62 (1.433)	76.57 (2.168)
40 (1016)	50.62 (1.433)	75.44 (2.136)
39 (991)	50.62 (1.433)	74.31 (2.104)
38 (965)	50.55 (1.431)	73.14 (2.071)
37 (940)	50.35 (1.426)	71.90 (2.036)
36 (914)	50.07 (1.418)	70.60 (1.999)
35 (889)	49.56 (1.403)	69.17 (1.959)
34 (864)	48.82 (1.382)	67.60 (1.914)
33 (838)	47.93 (1.357)	65.94 (1.867)
32 (813)	46.91 (1.328)	64.20 (1.818)
31 (787)	45.79 (1.297)	62.40 (1.767)
30 (762)	44.58 (1.262)	60.55 (1.715)
29 (737)	43.28 (1.226)	58.65 (1.661)
28 (711)	41.91 (1.187)	56.70 (1.606)
27 (686)	40.47 (1.146)	54.71 (1.549)
26 (660)	38.96 (1.103)	52.68 (1.492)
25 (635)	37.40 (1.059)	50.61 (1.433)
24 (610)	35.78 (1.013)	48.51 (1.374)
23 (584)	34.10 (0.966)	46.38 (1.313)
22 (559)	32.38 (0.917)	44.22 (1.252)
21 (533)	30.61 (0.867)	42.03 (1.190)
20 (508)	28.80 (0.816)	39.82 (1.128)
19 (483)	26.95 (0.763)	37.58 (1.064)
18 (457)	25.06 (0.710)	35.32 (1.000)
17 (432)	23.13 (0.655)	33.04 (0.936)
16 (406)	21.17 (0.599)	30.74 (0.870)
15 (381)	19.17 (0.543)	28.42 (0.805)
14 (356)	17.14 (0.485)	26.08 (0.739)
13 (330)	15.09 (0.427)	23.72 (0.672)
12 (305)	13.00 (0.368)	21.34 (0.604)
11 (279)	10.89 (0.308)	18.95 (0.537)
10 (254)	8.76 (0.248)	16.54 (0.468)
9 (229)	6.60 (0.187)	14.12 (0.400)
8 (203)	4.42 (0.125)	11.69 (0.331)
7 (178)	2.22 (0.063)	9.24 (0.262)
6 (152)	↑ 0 (0)	6.78 (0.192)
5 (127)	0 (0)	5.65 (0.160)
4 (102)	Stone 0 (0)	4.52 (0.128)
3 (76)	Foundation 0 (0)	3.39 (0.096)
2 (51)	↓ 0 (0)	2.26 (0.064)
1 (25)	0 (0)	1.13 (0.032)

**Note:** Add 1.13 ft<sup>3</sup> (0.032 m<sup>3</sup>) of storage for each additional inch (25 mm) of stone foundation.

### Storage Volume Per Chamber ft<sup>3</sup> (m<sup>3</sup>)

	Bare Chamber Storage ft <sup>3</sup> (m <sup>3</sup> )	Chamber and Stone Foundation Depth in. (mm)		
		6 (150)	12 (300)	18 (450)
SC-800 Chamber	50.6 (1.43)	81.0 (2.29)	87.8 (2.48)	94.6 (2.6)

**Note:** Assumes 6" (150 mm) stone above chambers, 6" (150 mm) row spacing and 40% stone porosity.

### Amount of Stone Per Chamber

English Tons (yds <sup>3</sup> )	Stone Foundation Depth		
	6"	12"	18"
SC-800	3.9 (2.8)	4.8 (3.4)	5.7 (4.1)
Metric Kilograms (m <sup>3</sup> )	150 mm	300 mm	450 mm
SC-800	3580 (2.2)	4380 (2.6)	5170 (3.1)

**Note:** Assumes 6" (150 mm) of stone above and between chambers.

### Volume Excavation Per Chamber yd<sup>3</sup> (m<sup>3</sup>)

	Stone Foundation Depth		
	6" (150 mm)	12" (300 mm)	18" (450 mm)
SC-800	5.6 (4.3)	6.3 (4.8)	6.9 (5.3)

**Note:** Assumes 6" (150 mm) of row separation and 18" (450 mm) of cover. The volume of excavation will vary as depth of cover increases.

## 2.0 Product Information

### 2.5 StormTech Chambers

StormTech chamber systems have unique features to improve site optimization and reduce product waste. The SC-160LP, SC-310, SC-740, DC-780 and SC-800 chambers can be cut at the job site in approximately 6.5 (165 mm) increments to shorten a chamber's length. Designing and constructing chamber rows around site obstacles is easily accomplished by including specific cutting instructions or a well placed cut to fit note on the design plans. The last chamber of a row can be cut in any of its corrugation's valleys. An end cap placed into the trimmed corrugation's crest completes the row. The trimmed-off piece of a StormTech chamber may then be used to start the next row.

To assist the contractor, StormTech chambers are molded with simple assembly instructions and arrows that indicate the direction in which to build rows. Rows are formed by overlapping the next chamber's Start End corrugation with the previously laid chamber's end corrugation. Two people can safely and efficiently form rows of chambers without complicated connectors, special tools or heavy equipment.

*Product Specifications: 2.2, 2.4, 2.5, 2.9 and 3.2.*

### 2.6 StormTech End Caps

The StormTech end cap has features which make the chamber system simple to design, easy to build and more versatile than other products. StormTech end caps can be easily secured within any corrugation's crest. A molded-in handle makes attaching the end cap a oneperson operation. Tools or fasteners are not required.

StormTech end caps are required at each end of a chamber row to prevent stone intrusion (two per row). The SC-740, DC-780 and SC-800 end caps will accept up to a 24 (600 mm) HDPE inlet pipe. The SC-310 end cap will accept up to a 12 (300 mm) HDPE inlet pipe. The SC-160LP will accept either a 6 or 8 (150 mm or 200 mm) HDPE inlet Pipe.

*Product Specifications: 3.1, 3.2, 3.3 and 3.4*

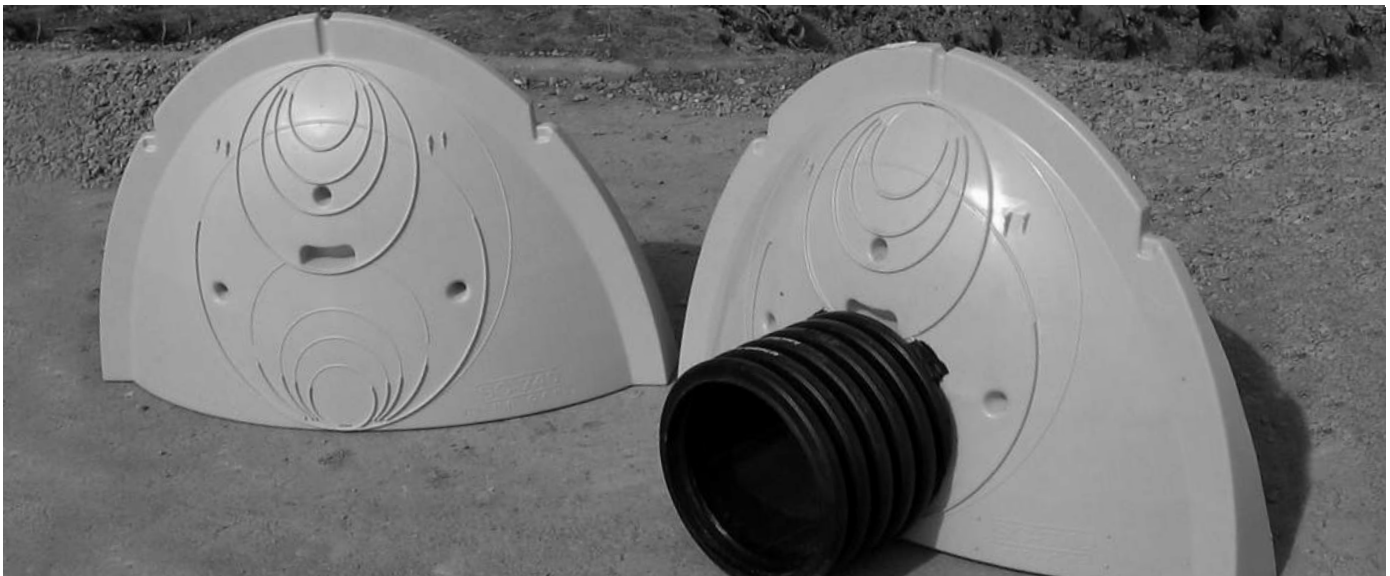

## 3.0 Structural Capabilities

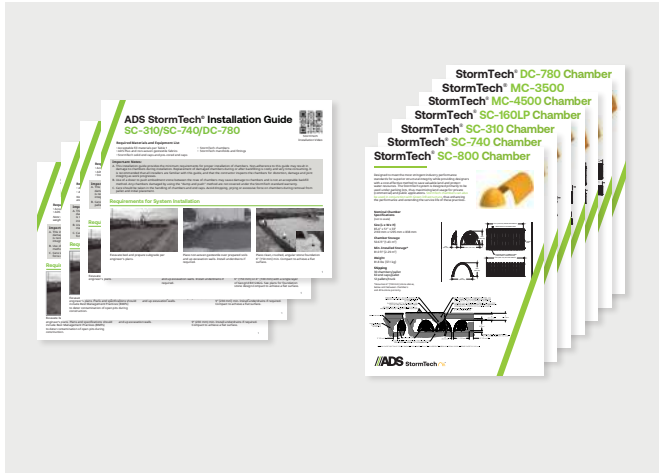

### 3.1 Structural Design Approach

When installed per StormTech's minimum requirements, StormTech products are designed to exceed American Association of State Highway and Transportation Officials (AASHTO) LRFD recommended design factors for Earth loads and Vehicular live loads. AASHTO Vehicular live loads (previously HS-20) consist of two heavy axle configurations, that of a single 32 (142 kN) kip axle and that of tandem 25 (111 kN) kip axles. Factors for impact and multiple presences of vehicles ensure a conservative design where structural adequacy is assumed for a wide range of street legal vehicle weights and axle configurations.

Computer models of the chambers under shallow and deep conditions were developed. Utilizing design forces from computer models, chamber sections were evaluated using AASHTO procedures that consider thrust and moment, and check for local buckling capacity. The procedures also considered the time-dependent strength and stiffness properties of polypropylene and polyethylene. These procedures were developed in a research study conducted by the National Cooperative Highway Research Program (NCHRP) for AASHTO, and published as NCHRP Report 438 Recommended LRFD Specifications for Plastic Pipe and Culverts. *Product Specifications: 2.12.*

StormTech does not recommend installing StormTech products underneath buildings or parking garages. When specifying the StormTech products in close proximity to buildings, it is important to ensure that the StormTech products are not receiving any loads from these structures that may jeopardize the long term performance of the chambers.

### 3.2 Full Scale Testing

After developing the StormTech chamber designs, the chambers were subjected to rigorous full-scale testing. The test programs verified the predicted safety factors of the designs by subjecting the chambers to more severe load conditions than anticipated during service life. Capacity under live loads and deep fill was investigated by conducting tests with a range of cover depths. Monitoring of long term deep fill installations has been done to validate the long term performance of the StormTech products.

### 3.3 Independent Expert Analysis

StormTech worked closely with the consulting firm Simpson Gumpertz & Heger Inc. (SGH) to develop and evaluate the SC-160LP, SC-310, SC-740, and DC-780 chamber designs. SGH has world-renowned expertise in the design of buried drainage structures. The firm was the principal investigator for the NCHRP research program that developed the structural analysis and design methods adopted by AASHTO for thermoplastic culverts. SGH conducted design calculations and computer simulations of chamber performance under various installation and live load conditions. They worked with StormTech to design the full-scale test programs to verify the structural capacity of the chambers. SGH also observed all full-scale tests and inspected the chambers after completion of the tests.

## 3.0 Structural Capabilities



### 3.4 Injection Molding

To comply with both the structural and design requirements of AASHTO's LRFD specifications and ASTM F2787 as well as the product requirements of ASTM F2418 or ASTM F2922, StormTech uses proprietary injection molding equipment to manufacture the chambers and end caps.

In addition to meeting structural goals, injection molding allows StormTech to design added features and advantages into StormTech's parts including:

- Precise control of wall thickness throughout parts
- Precise fit of joints and end caps
- Molded-in inspection port fitting
- Molded-in handles on end caps
- Molded-in pipe guides with blade starter slots
- Repeatability for Quality Control (See Section 3.6)

*Product Specifications: 2.1, 3.1 and 3.3*

### 3.5 Polypropylene and Polyethylene

StormTech chambers are injection molded from polypropylene and polyethylene. Polypropylene and polyethylene chambers are inherently resistant to chemicals typically found in stormwater run-off. StormTech chambers maintain a greater portion of their structural stiffness through higher installation and service temperatures.

StormTech polypropylene and polyethylene are virgin materials specially designed to achieve a high 75-year creep modulus that is necessary to provide a sound long-term structural design. Since the modulus remains high well beyond the 75-year value, StormTech chambers can exhibit a service life in excess of 75 years.

### 3.6 Quality Control

StormTech chambers are manufactured under tight quality control programs. Materials are routinely tested in an environmentally controlled lab that is verified every six months via the external ASTM Proficiency Testing Program. The chamber material properties are measured and controlled with procedures following ISO 9001:2000 requirements. Statistical Process Control (SPC) techniques are applied during manufacturing. Established upper and lower control limits are maintained on key manufacturing parameters to maintain consistent product.

*Product Specifications: 2.13 and 3.6*

# 4.0 Foundation for Chambers

## 4.1 Foundation Requirements

StormTech chamber systems and embedment stone may be installed in various native soil types. The subgrade bearing capacity and chamber cover height determine the required depth of clean, crushed, angular stone for the chamber foundation. The chamber foundation is the clean, crushed, angular stone placed between the subgrade soils and the feet of the chamber.

As cover height increases (top of chamber to top of finished grade) the chambers foundation requirements increase. Foundation strength is the product of the subgrade soils bearing capacity and the depth of clean, crushed, angular stone below the chamber foot. **Table 1** for the SC-160LP, **Table 2** for the SC-800, SC-740 and SC-310, **Table 3** for the SC-310-3, and **Table 4** for the DC-780 specify the required minimum foundation depth for varying cover heights and subgrade bearing capacities. For additional guidance on foundation stone design please see our Technical Note 6.22 - StormTech Subgrade Performance.

## 4.2 WEAKER SOILS

For sub-grade soils with allowable bearing capacity less than 2000 pounds per square foot [(2.0 ksf) (96 kPa)], a geotechnical engineer should evaluate the specific conditions. These soils are often highly

variable, may contain organic materials and could be more sensitive to moisture. A geotechnical engineer's recommendations may include increasing the stone foundation, improving the bearing capacity of the sub-grade soils through compaction, replacement, or other remedial measures including the use of geogrids. The use of a thermoplastic liner may also be considered for systems installed in subgrade soils that are highly affected by moisture. The project engineer is responsible for ensuring overall site settlement is within acceptable limits. A geotechnical engineer should always review installation of StormTech chambers on organic soils.

## 4.3 CHAMBER SPACING OPTION

No spacing is required between the SC-160LP chambers. StormTech requires a minimum of 6 (150 mm) clear spacing between the feet of chambers rows for the SC-310, SC-740, DC-780 and SC-800 chambers. However, increasing the spacing between chamber rows may allow the application of StormTech chambers with either less foundation stone or with weaker subgrade soils. This may be a good option where a vertical restriction on site prevents the use of a deeper foundation. Contact StormTech's Technical Service Department for more information on this option. In all cases, StormTech recommends consulting a geotechnical engineer for subgrade soils with a bearing capacity less than 2.0 ksf (96 kPa).

**Table 1 - SC-160LP Bearing Capacity Table**

(Assumes no spacing) Minimum Required Foundation Depth in Inches (mm)

Cover Hgt. ft. (m)	Minimum Bearing Resistance for Service Loads ksf (kPa)																		
	4.4-3.8 (211 to 182)	3.7 (177)	3.6 (172)	3.5 (168)	3.4 (163)	3.3 (158)	3.2 (153)	3.1 (148)	3.0 (144)	2.9 (139)	2.8 (134)	2.7 (129)	2.6 (124)	2.5 (120)	2.4 (115)	2.3 (110)	2.2 (105)	2.1 (101)	2.0 (95)
1.0 (0.31)	3 (75)	3 (75)	6 (150)	6 (150)	6 (150)	6 (150)	6 (150)	6 (150)	6 (150)	6 (150)	9 (230)	9 (230)	9 (230)	9 (230)	9 (230)	12 (300)	12 (300)	12 (300)	12 (300)
1.2 (0.46)	3 (75)	3 (75)	3 (75)	6 (150)	6 (150)	6 (150)	6 (150)	6 (150)	6 (150)	6 (150)	6 (150)	9 (230)	9 (230)	9 (230)	9 (230)	9 (230)	12 (300)	12 (300)	12 (300)
1.5 (0.46)	3 (75)	3 (75)	3 (75)	3 (75)	3 (75)	6 (150)	6 (150)	6 (150)	6 (150)	6 (150)	6 (150)	6 (150)	9 (230)	9 (230)	9 (230)	9 (230)	9 (230)	12 (300)	12 (300)
2.0 (0.61)	3 (75)	3 (75)	3 (75)	3 (75)	3 (75)	3 (75)	3 (75)	3 (75)	3 (75)	3 (75)	3 (75)	6 (150)	6 (150)	6 (150)	6 (150)	6 (150)	6 (150)	9 (230)	9 (230)
2.5 (0.76)	3 (75)	3 (75)	3 (75)	3 (75)	3 (75)	3 (75)	3 (75)	3 (75)	3 (75)	3 (75)	3 (75)	3 (75)	3 (75)	3 (75)	3 (75)	6 (150)	6 (150)	6 (150)	6 (150)
3.0 (0.91)	3 (75)	3 (75)	3 (75)	3 (75)	3 (75)	3 (75)	3 (75)	3 (75)	3 (75)	3 (75)	3 (75)	3 (75)	3 (75)	3 (75)	3 (75)	3 (75)	3 (75)	6 (150)	6 (150)
3.5 to 6.0 (1.07 to 1.86)	3 (75)	3 (75)	3 (75)	3 (75)	3 (75)	3 (75)	3 (75)	3 (75)	3 (75)	3 (75)	3 (75)	3 (75)	3 (75)	3 (75)	3 (75)	3 (75)	3 (75)	3 (75)	3 (75)
6.5 (1.98)	3 (75)	3 (75)	3 (75)	3 (75)	3 (75)	3 (75)	3 (75)	3 (75)	3 (75)	3 (75)	3 (75)	3 (75)	3 (75)	3 (75)	3 (75)	3 (75)	3 (75)	6 (150)	6 (150)
7.0 (2.13)	3 (75)	3 (75)	3 (75)	3 (75)	3 (75)	3 (75)	3 (75)	3 (75)	3 (75)	3 (75)	3 (75)	3 (75)	3 (75)	3 (75)	3 (75)	3 (75)	3 (75)	6 (150)	6 (150)
7.5 (2.30)	3 (75)	3 (75)	3 (75)	3 (75)	3 (75)	3 (75)	3 (75)	3 (75)	3 (75)	3 (75)	3 (75)	3 (75)	3 (75)	3 (75)	3 (75)	3 (75)	6 (150)	6 (150)	6 (150)
8.0 (2.44)	3 (75)	3 (75)	3 (75)	3 (75)	3 (75)	3 (75)	3 (75)	3 (75)	3 (75)	3 (75)	3 (75)	3 (75)	3 (75)	3 (75)	3 (75)	6 (150)	6 (150)	6 (150)	6 (150)
8.5 (2.59)	3 (75)	3 (75)	3 (75)	3 (75)	3 (75)	3 (75)	3 (75)	3 (75)	3 (75)	3 (75)	3 (75)	3 (75)	3 (75)	3 (75)	6 (150)	6 (150)	6 (150)	6 (150)	6 (150)
9.0 (2.74)	3 (75)	3 (75)	3 (75)	3 (75)	3 (75)	3 (75)	3 (75)	3 (75)	3 (75)	3 (75)	3 (75)	3 (75)	3 (75)	6 (150)	6 (150)	6 (150)	6 (150)	6 (150)	9 (230)
9.5 (2.89)	3 (75)	3 (75)	3 (75)	3 (75)	3 (75)	3 (75)	3 (75)	3 (75)	3 (75)	3 (75)	3 (75)	3 (75)	3 (75)	6 (150)	6 (150)	6 (150)	6 (150)	9 (230)	9 (230)
10.0 (3.05)	3 (75)	3 (75)	3 (75)	3 (75)	3 (75)	3 (75)	3 (75)	3 (75)	3 (75)	3 (75)	3 (75)	3 (75)	6 (150)	6 (150)	6 (150)	6 (150)	9 (230)	9 (230)	9 (230)

**Note:** The design engineer is solely responsible for assessing the bearing resistance (allowable bearing capacity) of the subgrade soils and determining the depth of foundation stone. Subgrade bearing resistance should be assessed with consideration for the range of soil moisture conditions expected under a stormwater system.

# 4.0 Foundations for Chambers

**Table 6 - SC-800 Minimum Required Foundation Depth in inches (millimeters)**

Cover Hgt. ft (m)	Minimum Required Bearing Resistance for Service Loads ksf (kPa)																									
	4.4 (211)	4.3 (206)	4.2 (201)	4.1 (196)	4.0 (192)	3.9 (187)	3.8 (182)	3.7 (177)	3.6 (172)	3.5 (168)	3.4 (163)	3.3 (158)	3.2 (153)	3.1 (148)	3.0 (144)	2.9 (139)	2.8 (134)	2.7 (129)	2.6 (124)	2.5 (120)	2.4 (115)	2.3 (110)	2.2 (105)	2.1 (101)	2.0 (96)	
<b>1.25 (0.38)</b>	6 (150)	6 (150)	6 (150)	6 (150)	6 (150)	6 (150)	6 (150)	6 (150)	6 (150)	6 (150)	6 (150)	6 (150)	6 (150)	6 (150)	6 (150)	9 (230)	9 (230)	9 (230)	9 (230)	9 (230)	12 (300)	12 (300)	12 (300)	12 (300)	12 (300)	15 (375)
<b>1.5 (0.46)</b>	6 (150)	6 (150)	6 (150)	6 (150)	6 (150)	6 (150)	6 (150)	6 (150)	6 (150)	6 (150)	6 (150)	6 (150)	6 (150)	6 (150)	9 (230)	9 (230)	9 (230)	9 (230)	9 (230)	9 (230)	12 (300)	12 (300)	12 (300)	12 (300)	15 (375)	15 (375)
<b>2.0 (0.61)</b>	6 (150)	6 (150)	6 (150)	6 (150)	6 (150)	6 (150)	6 (150)	6 (150)	6 (150)	6 (150)	6 (150)	6 (150)	6 (150)	9 (230)	9 (230)	9 (230)	9 (230)	9 (230)	9 (230)	12 (300)	12 (300)	12 (300)	12 (300)	15 (375)	15 (375)	
<b>2.5 (0.76)</b>	6 (150)	6 (150)	6 (150)	6 (150)	6 (150)	6 (150)	6 (150)	6 (150)	6 (150)	6 (150)	6 (150)	6 (150)	9 (230)	9 (230)	9 (230)	9 (230)	9 (230)	9 (230)	12 (300)	12 (300)	12 (300)	12 (300)	15 (375)	15 (375)	15 (375)	
<b>3.0 (0.91)</b>	6 (150)	6 (150)	6 (150)	6 (150)	6 (150)	6 (150)	6 (150)	6 (150)	6 (150)	6 (150)	6 (150)	9 (230)	9 (230)	9 (230)	9 (230)	9 (230)	9 (230)	12 (300)	12 (300)	12 (300)	12 (300)	15 (375)	15 (375)	15 (375)	18 (450)	
<b>3.5 (1.07)</b>	6 (150)	6 (150)	6 (150)	6 (150)	6 (150)	6 (150)	6 (150)	6 (150)	6 (150)	6 (150)	9 (230)	9 (230)	9 (230)	9 (230)	9 (230)	9 (230)	12 (300)	12 (300)	12 (300)	12 (300)	15 (375)	15 (375)	15 (375)	18 (450)	18 (450)	
<b>4.0 (1.22)</b>	6 (150)	6 (150)	6 (150)	6 (150)	6 (150)	6 (150)	6 (150)	6 (150)	6 (150)	6 (150)	9 (230)	9 (230)	9 (230)	9 (230)	9 (230)	9 (230)	12 (300)	12 (300)	12 (300)	12 (300)	15 (375)	15 (375)	15 (375)	18 (450)	18 (450)	
<b>4.5 (1.37)</b>	6 (150)	6 (150)	6 (150)	6 (150)	6 (150)	6 (150)	6 (150)	6 (150)	6 (150)	6 (150)	9 (230)	9 (230)	9 (230)	9 (230)	9 (230)	9 (230)	12 (300)	12 (300)	12 (300)	12 (300)	15 (375)	15 (375)	15 (375)	18 (450)	18 (450)	
<b>5.0 (1.52)</b>	6 (150)	6 (150)	6 (150)	6 (150)	6 (150)	6 (150)	6 (150)	6 (150)	6 (150)	6 (150)	9 (230)	9 (230)	9 (230)	9 (230)	9 (230)	9 (230)	12 (300)	12 (300)	12 (300)	12 (300)	15 (375)	15 (375)	15 (375)	18 (450)	18 (450)	
<b>5.5 (1.68)</b>	6 (150)	6 (150)	6 (150)	6 (150)	6 (150)	6 (150)	6 (150)	6 (150)	6 (150)	9 (230)	9 (230)	9 (230)	9 (230)	9 (230)	9 (230)	12 (300)	12 (300)	12 (300)	12 (300)	15 (375)	15 (375)	15 (375)	18 (450)	18 (450)	18 (450)	
<b>6.0 (1.83)</b>	6 (150)	6 (150)	6 (150)	6 (150)	6 (150)	6 (150)	6 (150)	6 (150)	9 (230)	9 (230)	9 (230)	9 (230)	9 (230)	9 (230)	12 (300)	12 (300)	12 (300)	12 (300)	15 (375)	15 (375)	15 (375)	18 (450)	18 (450)	18 (450)	21 (525)	
<b>6.5 (1.98)</b>	6 (150)	6 (150)	6 (150)	6 (150)	6 (150)	6 (150)	6 (150)	9 (230)	9 (230)	9 (230)	9 (230)	9 (230)	9 (230)	12 (300)	12 (300)	12 (300)	12 (300)	12 (300)	15 (375)	15 (375)	15 (375)	18 (450)	18 (450)	18 (450)	21 (525)	
<b>7.0 (2.13)</b>	6 (150)	6 (150)	6 (150)	6 (150)	6 (150)	6 (150)	9 (230)	9 (230)	9 (230)	9 (230)	9 (230)	9 (230)	12 (300)	12 (300)	12 (300)	12 (300)	12 (300)	15 (375)	15 (375)	15 (375)	18 (450)	18 (450)	18 (450)	21 (525)	21 (525)	
<b>7.5 (2.30)</b>	6 (150)	6 (150)	6 (150)	6 (150)	6 (150)	9 (230)	9 (230)	9 (230)	9 (230)	9 (230)	9 (230)	12 (300)	12 (300)	12 (300)	12 (300)	12 (300)	15 (375)	15 (375)	15 (375)	18 (450)	18 (450)	18 (450)	21 (525)	21 (525)	24 (600)	
<b>8.0 (2.44)</b>	6 (150)	6 (150)	6 (150)	9 (230)	9 (230)	9 (230)	9 (230)	9 (230)	9 (230)	9 (230)	12 (300)	12 (300)	12 (300)	12 (300)	12 (300)	15 (375)	15 (375)	15 (375)	18 (450)	18 (450)	18 (450)	21 (525)	21 (525)	21 (525)	24 (600)	

**Note:** The design engineer is solely responsible for assessing the bearing resistance (allowable bearing capacity) of the subgrade soils and determining the depth of foundation stone. Subgrade bearing resistance should be assessed with consideration for the range of soil moisture conditions expected under a stormwater system.

## 5.0 Cumulative Storage Volumes

Tables 7, 8, 9, 10, and 11 provide cumulative storage volumes for the SC-160LP, SC-310, SC-740 and DC-780 chamber systems. This information may be used to calculate a detention/retention system's stage storage volume. A spreadsheet is available at [www.adspipe.com/stormtech](http://www.adspipe.com/stormtech) in which the number of chambers can be input for quick cumulative storage calculations.

Product Specifications: 1.1, 2.2, 2.3, 2.4, and 2.6

**Table 7 - SC-160LP Cumulative Storage Volumes Per Chamber**

Assumes 40% Stone Porosity. Calculations are Based Upon a 4" (100 mm) Stone Base Under the Chambers.

Depth of Water in System Inches (mm)	Cumulative Chamber Storage ft <sup>3</sup> (m <sup>3</sup> )	Total System Cumulative Storage ft <sup>3</sup> (m <sup>3</sup> )
22 (559)	6.85 (0.194)	14.98 (0.424)
21 (533)	6.85 (0.194)	14.49 (0.410)
20 (508)	6.85 (0.194)	14.00 (0.396)
19 (483)	6.85 (0.194)	13.50 (0.382)
18 (457)	6.85 (0.194)	13.01 (0.368)
17 (432)	6.85 (0.194)	12.51 (0.354)
16 (406)	6.85 (0.194)	12.02 (0.340)
15 (381)	6.80 (0.193)	11.49 (0.325)
14 (356)	6.67 (0.189)	10.92 (0.309)
13 (330)	6.38 (0.181)	10.25 (0.290)
12 (305)	5.94 (0.168)	9.49 (0.269)
11 (279)	5.40 (0.153)	8.67 (0.246)
10 (254)	4.78 (0.135)	7.81 (0.221)
9 (229)	4.10 (0.116)	6.91 (0.196)
8 (203)	3.36 (0.095)	5.97 (0.169)
7 (178)	2.58 (0.073)	5.01 (0.142)
6 (152)	1.76 (0.050)	4.02 (0.114)
5 (127)	0.89 (0.025)	3.01 (0.085)
4 (102)	0 (0)	1.98 (0.056)
3 (76)	0 (0)	1.48 (0.042)
2 (51)	0 (0)	0.99 (0.028)
1 (25)	0 (0)	0.49 (0.014)

**Note:** Add 0.49 ft<sup>3</sup> (0.014 m<sup>3</sup>) of storage for each additional inch (25 mm) of stone foundation.

**Table 8 - SC-310 Cumulative Storage Volumes Per Chamber**

Assumes 40% Stone Porosity. Calculations are Based Upon a 6" (150 mm) Stone Base Under the Chambers.

Depth of Water in System Inches (mm)	Cumulative Chamber Storage ft <sup>3</sup> (m <sup>3</sup> )	Total System Cumulative Storage ft <sup>3</sup> (m <sup>3</sup> )
28 (711)	14.70 (0.416)	31.00 (0.878)
27 (686)	14.70 (0.416)	30.21 (0.855)
26 (680)	14.70 (0.416)	29.42 (0.833)
25 (635)	14.70 (0.416)	28.63 (0.811)
24 (610)	14.70 (0.416)	27.84 (0.788)
23 (584)	14.70 (0.416)	27.05 (0.766)
22 (559)	14.70 (0.416)	26.26 (0.748)
21 (533)	14.64 (0.415)	25.43 (0.720)
20 (508)	14.49 (0.410)	24.54 (0.695)
19 (483)	14.22 (0.403)	23.58 (0.668)
18 (457)	13.68 (0.387)	22.47 (0.636)
17 (432)	12.99 (0.368)	21.25 (0.602)
16 (406)	12.17 (0.345)	19.97 (0.566)
15 (381)	11.25 (0.319)	18.62 (0.528)
14 (356)	10.23 (0.290)	17.22 (0.488)
13 (330)	9.15 (0.260)	15.78 (0.447)
12 (305)	7.99 (0.227)	14.29 (0.425)
11 (279)	6.78 (0.192)	12.77 (0.362)
10 (254)	5.51 (0.156)	11.22 (0.318)
9 (229)	4.19 (0.119)	9.64 (0.278)
8 (203)	2.83 (0.081)	8.03 (0.227)
7 (178)	1.43 (0.041)	6.40 (0.181)
6 (152)	0	4.74 (0.134)
5 (127)	0	3.95 (0.112)
4 (102)	0	3.16 (0.090)
3 (76)	0	2.37 (0.067)
2 (51)	0	1.58 (0.046)
1 (25)	0	0.79 (0.022)

**Note:** Add 0.79 ft<sup>3</sup> (0.022 m<sup>3</sup>) of storage for each additional inch (25 mm) of stone foundation.

# 5.0 Cumulative Storage Volumes

**Table 11 - SC-800 Cumulative Storage Volumes Per Chamber**

*Assumes 40% Stone Porosity. Calculations are Based Upon a 6" (150 mm) Stone Base Under the Chambers.*

Depth of Water in System Inches (mm)	Cumulative Chamber Storage ft <sup>3</sup> (m <sup>3</sup> )	Total System Cumulative Storage ft <sup>3</sup> (m <sup>3</sup> )
45 (1143)	50.62 (1.433)	81.08 (2.296)
44 (1118)	50.62 (1.433)	79.96 (2.264)
43 (1092)	50.62 (1.433)	78.83 (2.232)
42 (1067)	50.62 (1.433)	77.70 (2.200)
41 (1041)	50.62 (1.433)	76.57 (2.168)
40 (1016)	50.62 (1.433)	75.44 (2.136)
39 (991)	50.62 (1.433)	74.31 (2.104)
38 (965)	50.55 (1.431)	73.14 (2.071)
37 (948)	50.35 (1.426)	71.90 (2.036)
36 (914)	50.07 (1.418)	70.60 (1.999)
35 (889)	49.56 (1.403)	69.17 (1.959)
34 (864)	48.82 (1.382)	67.60 (1.914)
33 (838)	47.93 (1.357)	65.94 (1.867)
32 (813)	46.91 (1.328)	64.20 (1.818)
31 (787)	45.79 (1.297)	62.40 (1.767)
30 (762)	44.58 (1.262)	60.55 (1.715)
29 (737)	43.28 (1.226)	58.65 (1.661)
28 (711)	41.91 (1.187)	56.70 (1.606)
27 (686)	40.47 (1.146)	54.71 (1.549)
26 (660)	38.96 (1.103)	52.68 (1.492)
25 (635)	37.40 (1.059)	50.61 (1.433)
24 (610)	35.78 (1.013)	48.51 (1.374)
23 (584)	34.10 (0.966)	46.38 (1.313)
22 (559)	32.38 (0.917)	44.22 (1.252)
21 (533)	30.61 (0.867)	42.03 (1.190)
20 (508)	28.80 (0.816)	39.82 (1.128)
19 (483)	26.95 (0.763)	37.58 (1.064)
18 (457)	25.06 (0.710)	35.32 (1.000)
17 (432)	23.13 (0.655)	33.04 (0.936)
16 (406)	21.17 (0.599)	30.74 (0.870)
15 (381)	19.17 (0.543)	28.42 (0.805)
14 (356)	17.14 (0.485)	26.08 (0.739)
13 (330)	15.09 (0.427)	23.72 (0.672)
12 (305)	13.00 (0.368)	21.34 (0.604)
11 (279)	10.89 (0.308)	18.95 (0.537)
10 (254)	8.76 (0.248)	16.54 (0.468)
9 (229)	6.60 (0.187)	14.12 (0.400)
8 (203)	4.42 (0.125)	11.69 (0.331)
7 (178)	2.22 (0.063)	9.24 (0.262)
6 (152)	0 (0)	6.78 (0.192)
5 (127)	0 (0)	5.65 (0.160)
4 (102)	0 (0)	4.52 (0.128)
3 (76)	0 (0)	3.39 (0.096)
2 (51)	0 (0)	2.26 (0.064)
1 (25)	0 (0)	1.13 (0.032)

**Note:** Add 1.13 ft<sup>3</sup> (0.032 m<sup>3</sup>) of storage for each additional inch (25 mm) of stone foundation.

# 6.0 Required Materials/Row Separation

## 6.1 Chamber Row Separation

StormTech SC-740, SC-310, DC-780, and SC-800 chambers must be specified with a minimum 6 (150 mm) space between the feet of adjacent parallel chamber rows. No spacing is required between the SC-160LP chambers. Increasing the space between rows is acceptable. This will increase the storage volume due to additional stone voids.

## 6.2 Stone Surrounding Chambers

Refer to **Table 8** for acceptable stone materials. StormTech requires clean, crushed, angular stone below, between and above chambers as shown in **Figure 4**. Acceptable gradations are listed in **Table 8**. Subrounded and rounded stone are not acceptable.

## 6.3 Geotextile Separation Requirement

A non-woven geotextile that meets AASHTO M288 Class 2 Separation requirements must be applied as a separation layer to prevent soil intrusion into the clean, crushed, angular stone as shown in **Figure 4**.

The geotextile is required between the clean, crushed, angular stone and the subgrade soils, the excavation's sidewalls and the fill materials. The geotextile should completely envelope the clean, crushed, angular stone. Overlap adjacent geotextile rolls per AASHTO M288 separation guidelines. Contact StormTech for a list of acceptable geotextiles.

## 6.4 Fill Above Chambers

Refer to **Table 8** and **Figure 4** for acceptable fill material above the 6" (150 mm) of clean, crushed, angular stone. Minimum and maximum fill requirements for the SC-160LP, SC-740, SC-310, DC-780, and SC-800 chambers are shown in **Figure 4** below. StormTech requires 6" (150 mm) of fill material in addition to the chamber specific minimum cover requirements in non-paved installations where rutting from vehicles may occur. **Table 8** provides details on soil class and compaction requirements for suitable fill materials.

**Table 8 – Acceptable Fill Materials**

Material Location	Description	AASHTO Material Classifications	Compaction / Density Requirement
<b>D</b>	<b>Final Fill:</b> Fill material for layer 'D' starts from the top of the 'C' layer to the bottom of the flexible pavement to unpaved finished grade above. Note that pavement subbase may be part of the 'D' layer.	N/A	Prepare per site design Engineer's plans. Paved installations may have stringent material and preparation requirements.
<b>C</b>	<b>Initial Fill:</b> Fill material for layer 'C' starts from the top of the embedment stone ('B' Layer) to 18 (450 mm) above the top of the chamber. Note that pavement subbase may be a part of the 'C' layer.	AASHTO M145 <sup>1</sup> A-1, A-2-4, A-3 OR AASHTO M43 <sup>1</sup> 3, 357, 4, 467, 5, 56, 57, 6, 67, 68, 7, 78, 8, 89, 9, 10	Begin Compactions after 12 (300 mm) of material over the chambers is reached. Compact additional layers in 6 (150 mm) max lifts to a min. 95% proctor density for well graded material and 95% relative Density for processed aggregate materials. Roller gross vehicle weight not to exceed 12,000 lbs (53 kN). Dynamic force not to exceed 20,000 lbs (89 kN)
<b>B</b>	<b>Embedment stone:</b> Fill surrounding the chambers from the foundation stone ('A' layer) to the 'C' layer above	AASHTO M145 <sup>1</sup> 3, 357, 4, 467, 5, 56, 57	No compaction required.
<b>A</b>	<b>Foundation stone:</b> Fill below chambers from the subgrade up to the foot (bottom) of the chamber.	AASHTO M145 <sup>1</sup> 3, 357, 4, 467, 5, 56, 57	Plate compact or roll to achieve a flat surface. <sup>2,3</sup>

**Please Note:**

- The listed AASHTO designations are for gradations only. The stone must also be clean, crushed, angular. For example, a specification for #4 Stone would state: clean, crushed, angular No. 4 (AASHTO M43) Stone.
- StormTech compaction requirements are met for 'A' location materials when placed and compacted in 6 (150 mm) (MAX) Lifts using two full coverages with a vibratory compactor.
- Where infiltration surfaces may be compromised by compaction, for standard design load conditions, a flat surface may be achieved by raking of dragging without compaction equipment. For special load designs, contact StormTech for compaction requirements.
- Where recycled concrete aggregate is used in layers 'A' or 'B' the material should also meet the acceptable criteria outlined in ADS Technical Note 6.20 "Recycled Concrete Structural Backfill".

**Figure 4 – Fill Material Locations**

Once 'C' is placed any soil/material can be placed in layer 'D' up to the finished grade. Most pavement subbase soils can be used to replace the materials requirements of 'C' or 'D' at the design engineer's discretion.

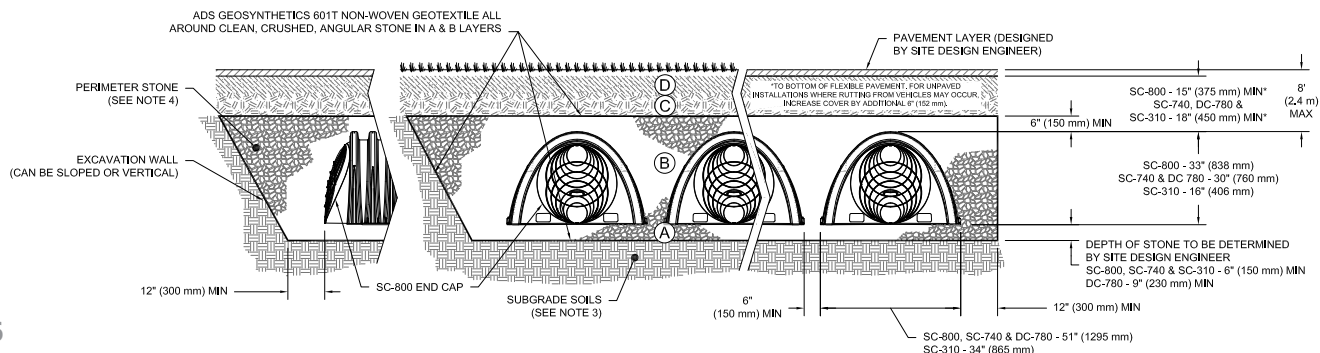

# 7.0 Inletting the Chambers

The design flexibility of a StormTech chamber system includes many inletting possibilities. Contact StormTech’s Technical Service Department for guidance on designing an inlet system to meet specific site goals.

## 7.1 Treatment Train

A properly designed inlet system can ensure good water quality, easy inspection and maintenance, and a long system service life. StormTech recommends a treatment train approach for inletting an underground stormwater management system under a typical commercial parking area. Treatment train is an industry term for a multi-tiered water quality network. As shown in **Figure 5**, a StormTech recommended inlet system can inexpensively have tiers of treatment upstream of the StormTech chambers:

**Tier 1 – Pre-treatment (BMP)**

**Tier 2 - StormTech Isolator® Row Plus**

**Tier 3 - Enhanced Treatment (BMP)**

**Figure 5 - Typical StormTech Treatment Train Inlet System**

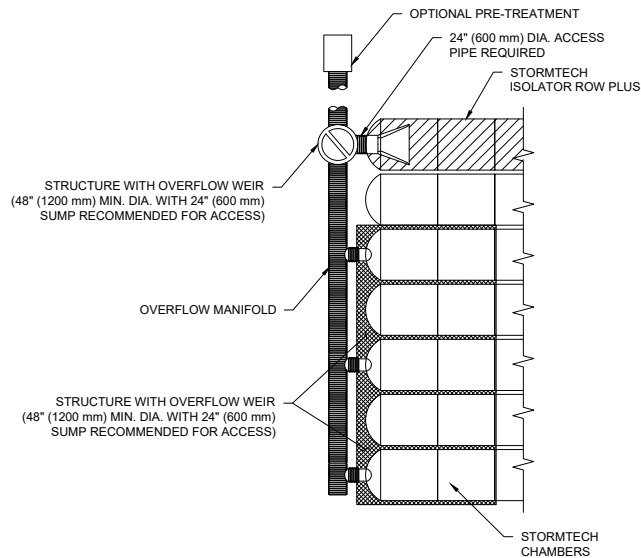

## 7.2 Pre-Treatment (BMP) – Treatment Tier 1

In some areas pre-treatment of the stormwater is required prior to entry into a stormwater system. By treating the stormwater prior to entry into the system, the service life of the system can be extended, pollutants such as hydrocarbons may be captured, and local regulations met. Pre-treatment options are often described as a Best Management Practice or simply a BMP.

Pre-treatment devices differ greatly in complexity, design and effectiveness. Depending on a site’s characteristics and treatment goals, the simple, least expensive pretreatment solutions can sometimes be just as effective as the complex systems. Options include a simple deep sumped manhole with a 90° bend on its outlet, baffle boxes, swirl concentrators,

and devices that combine these processes. Some of the most effective pretreatment options combine engineered site grading with vegetation such as bio-swales or grassy strips.

The type of pretreatment device specified as the first level of treatment up-stream of a StormTech chamber system can vary greatly throughout the country and from site-to-site. It is the responsibility of the design engineer to understand the water quality requirements and design a stormwater treatment system that will satisfy local regulators and follow applicable laws. A design engineer should apply their understanding of local weather conditions, site topography, local maintenance requirements, expected service life, etc. to select an appropriate stormwater pre-treatment system.

## 7.3 StormTech Isolator Row Plus – Treatment Tier 2

StormTech has a patented technique to inexpensively enhance Total Suspended Solids (TSS) removal and provide easy access for inspection and maintenance. The StormTech Isolator Row Plus is a row of standard StormTech chambers surrounded with appropriate filter fabrics and connected to a manhole for easy access. This application basically creates a filter/detention basin that allows water to egress through the surrounding filter fabric while sediment is trapped within. It may be best to think of the Isolator Row Plus as a first-flush treatment device. First-Flush is a term typically used to describe the first 1/2 to 1 (13-25 mm) of rainfall or runoff on a site. The majority of stormwater pollutants are carried in the sediments of the firstflush, therefore the Isolator Row Plus is an effective component of a treatment train.

The StormTech Isolator Row Plus should be designed with a manhole with an overflow weir at its upstream end. The diversion manhole is multi-purposed. It can provide access to the Isolator Row Plus for both inspection and maintenance and acts as a diversion structure. The manhole is connected to the Isolator Row Plus with a short length of 8 (200mm) pipe for the SC-160LP chambers, 12 (300 mm) pipe for the SC-310 chamber and 24 (600 mm) pipe for the SC-740, DC-780 and SC-800 chambers. These pipes are connected to the Isolator Row Plus with an 8 (200mm) precored end cap for the SC-160LP, a 12 (300 mm) fabricated end cap for the SC-310 chamber and a 24 (600 mm) fabricated end cap for the SC-740, DC-780 and SC-800 chambers. The overflow weir typically has its crest set between the top of the chamber and its midpoint. This allows storm water in excess of the Isolator Row Plus’s storage/conveyance capacity to bypass into the chamber system through the downstream manifold system.

Specifying and installing proper geotextiles is essential for efficient operation and to prevent damage to the system during the JetVac

# 7.0 Inletting the Chambers

Figure 6 – StormTech Isolator Row PLUS Detail

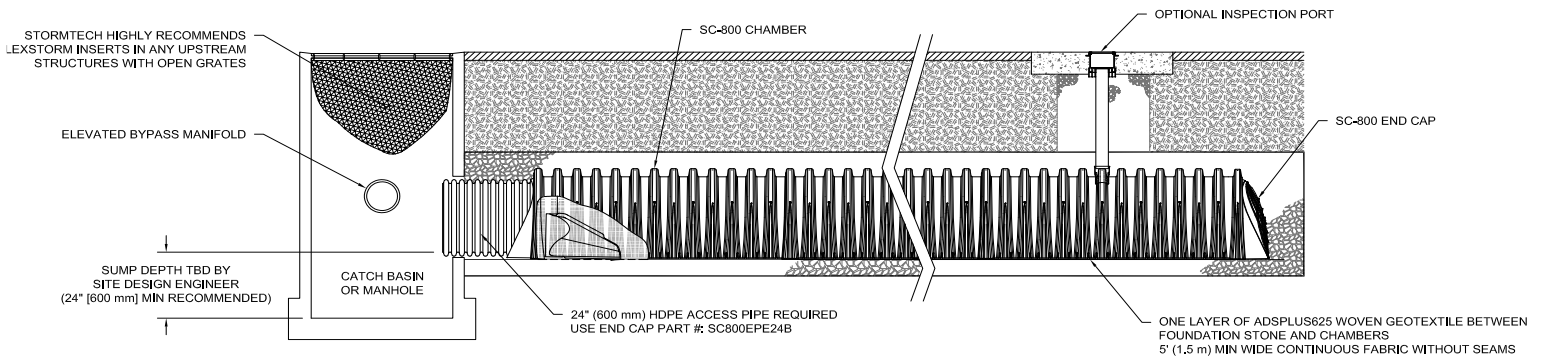

maintenance process. In a typical configuration, a single layer of ADS Plus fabric is placed between the chambers and stone foundation. This fabric traps and filters sediments as well as protects the stone base during cleaning and maintenance. **Figure 6** is a detail of the Isolator Row Plus that shows proper application of the geotextiles. Contact StormTech for a table of acceptable geotextiles.

For SC-310, SC-740 and SC-800 Isolator Plus Rows, a FLAMP (flared end ramp) is attached to the inlet pipe on the inside of the chamber end cap to provide a smooth transition from pipe invert to fabric bottom. It is configured to improve chamber function performance over time by distributing sediment and debris that would otherwise collect at the inlet. It also serves to improve the fluid and solid flow back into the inlet pipe during maintenance and cleaning, and to guide cleaning and inspection equipment back into the inlet pipe when complete.

Inspection is easily accomplished through the upstream manhole or optional inspection ports. Maintenance of an Isolator Row Plus is fast and easy using the JetVac process through the upstream manhole. Section 12.0 explains the inspection and maintenance process in more detail.



Isolator Plus Rows can be sized to accommodate either a water quality volume or a water quality flow rate requirement. The use of filter fabric around the Isolator Row Plus chambers allows stormwater to egress out of the row during and between storm events. The rate of egression for design is dependent upon the chamber model and

sediment accumulation on the geotextile. Contact StormTech's Technical Services Department for more information on Isolator Row Plus sizing.

## 7.4 Enhanced Treatment (BMP) – Treatment Tier 3

As regulations have become more stringent, requiring higher levels of containment removal, water quality systems may be required to treat higher flow rates, greater volumes or to provide a higher level of filtration or other more sophisticated treatment process. StormTech systems can easily be configured with enhanced treatment techniques located either upstream or downstream of the retention or detention chamber system. Located upstream of an infiltration bed, between the pretreatment device and the Isolator Row Plus, enhanced treatment provides a high level of contaminant removal which protects groundwater or better preserves the infiltration surface. Located downstream of detention, enhanced treatment provides a higher level of contaminant removal prior to discharge to a receiving body. Enhanced treatment BMPs are normally applied where specific regulations and specific water quality product approvals are in place. StormTech works closely with providers of enhanced treatment technologies to meet local requirements.

## 7.5 TREATMENT TRAIN CONCLUSION

The treatment train is a highly effective water-quality approach that may not add significant cost to a StormTech system being installed under commercial parking areas. The StormTech Isolator Row Plus adds a significant level of treatment, easy inspection and maintenance, while maintaining storage volume credit for the cost of a modest amount of geotextile. Finally where higher levels of treatment are required, StormTech can integrate other technologies into the treatment train to provide the most cost effective treatment approach. This treatment train concept provides three levels of treatment, inspection and maintenance upstream and downstream of the StormTech detention/retention bed.

# 7.0 Inletting the Chambers

## 7.6 Other Inlet Options

While the three-tiered treatment train approach is the recommended method of inletting StormTech chambers for typical under-commercial parking applications, there are other effective inlet methods that may be considered. For instance, the Isolator Row PLUS, while adding an inexpensive level of confidence, are not always necessary. A header system with fewer inlets can be designed to further minimize the cost of a StormTech system. There may be applications where stormwater pre-treatment may not be necessary at all and the system can be inlet directly from the source. Contact StormTech's Technical Service Department to discuss inlet options.

## 7.7 Lateral Flow Rates

The embedment stone surrounding the StormTech chambers allows the rapid conveyance of stormwater between chamber rows. Stormwater will rise and fall evenly within a bed of chambers. A single StormTech SC-740 chamber is able to release or accept stormwater at a rate of at least 0.5 cfs (14.2 l/s) through the surrounding stone.

## 7.8 Inletting Perpendicular to a Row of Chambers with Inserta Tee

There is an easy, inexpensive method to perpendicularly inlet a row of chambers. Simply connect the inlet directly to the chamber with an Inserta Tee. Figure 7 shows a typical detail along with the standard sizes offered for each chamber model.

**Figure 7 – Inserta Tee Side Detail**

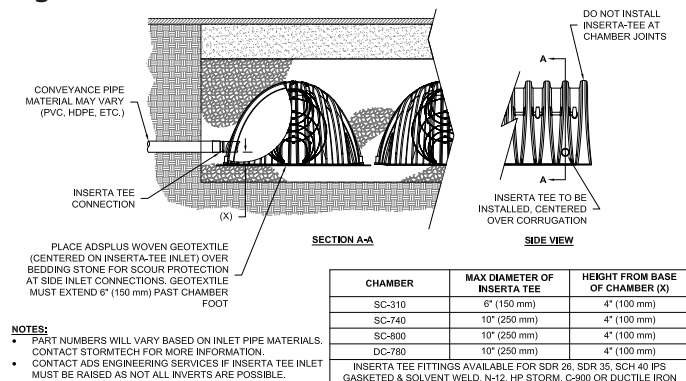

**NOTE:** Side Inserta Tees Cannot be used on SC-160LP Chambers.

## 7.9 Maximum Inlet Pipe Velocities to prevent Scouring of the Stone Foundation

The primary function of the inlet manifold is to convey and distribute flows to a sufficient number of rows in the chamber bed such that there is ample conveyance capacity to pass the peak flows without creating an unacceptable backwater condition in upstream piping or scour the foundation stone under the chambers.

Manifolds are connected to the end caps either at the top or bottom of the end cap. High inlet flow rates from either connection location produce a shear scour potential of the foundation stone. Inlet flows from top inlets also produce impingement scour potential. Scour potential is reduced when standing water is present over the foundation stone. However, for safe design across the wide range of applications, StormTech assumes minimal standing water at the time the design flow occurs.

To minimize scour potential, StormTech recommends the installation of woven scour protection fabric at each inlet row. This enables a protected transition zone from the concentrated flow coming out of the inlet pipe to a uniform flow across the entire width of the chamber for both top and bottom connections. Allowable flow rates for design are dependent upon: the elevation of inlet pipe, foundation stone size and scour protection. An appropriate scour protection geotextile is installed from the end cap to at least 10.5' (3.2 m) for the SC-310, SC-740, DC 780 and SC-800 chambers for both top and bottom feeding inlet pipes.

See StormTech's Tech Note 6.32 for guidance on manifold sizing. ADS's Technical Services department can also assist with sizing inlet manifolds for the StormTech chamber systems.

# 7.0 Inletting the Chambers

Table 9A – Standard Distances from Base of Chamber to Invert of Inlet and Outlet Manifolds on StormTech End Caps

SC-160LP End Caps			
Pipe Diameter	Inv. (in)	Inv. (ft)	Inv. (mm)
6 (150 mm)	0.66	0.05	16
8 (200 mm)	0.80	0.07	20
8 (200 mm) Cored	0.96	0.08	24

SC-310 End Caps				
Pipe Diameter	Inv. (in)	Inv. (ft)	Inv. (mm)	
TOP	6 (150 mm)	5.8	0.48	146
	8 (200 mm)	3.5	0.29	88
	10 (250 mm)	1.4	0.12	37
BOTTOM	6 (150 mm)	0.5	0.04	12
	8 (200 mm)	0.6	0.05	15
	10 (250 mm)	0.7	0.06	18
	12 (300 mm)	0.9	0.08	24

SC-740 / DC-780 End Caps				
Pipe Diameter	Inv. (in)	Inv. (ft)	Inv. (mm)	
TOP	6 (150 mm)	18.5	1.54	469
	8 (200 mm)	16.5	1.38	421
	10 (250 mm)	14.5	1.21	369
	12 (300 mm)	12.5	1.04	317
	15 (375 mm)	9	0.75	229
	18 (450 mm)	5	0.42	128
BOTTOM	6 (150 mm)	0.5	0.04	12
	8 (200 mm)	0.6	0.05	15
	10 (250 mm)	0.7	0.06	18
	12 (300 mm)	1.2	0.10	30
	15 (375 mm)	1.3	0.11	34
	18 (450 mm)	1.6	0.13	40
	24 (600 mm)	0.1	0.01	3

SC-800 End Caps				
Pipe Diameter	Inv. (in)	Inv. (ft)	Inv. (mm)	
TOP	6 (150 mm)	0.9	0.08	23
	8 (200 mm)	1.0	0.08	25
	10 (250 mm)	1.2	0.10	30
	12 (300 mm)	1.6	0.13	41
	15 (375 mm)	1.7	0.14	43
	18 (450 mm)	2.0	0.17	51
BOTTOM	6 (150 mm)	21.4	1.78	544
	8 (200 mm)	19.2	1.60	488
	10 (250 mm)	17.0	1.42	432
	12 (300 mm)	14.4	1.20	366
	15 (375 mm)	11.3	0.94	287
	18 (450 mm)	8.0	0.67	203
	24 (600 mm)	2.3	0.19	58

\*See StormTech's Tech Note 6.32 for manifold sizing guidance\*

# 8.0 Outlets for Chambers

## 8.0 Outlets for StormTech Chamber Systems

The majority of StormTech installations are detention systems and have some type of outlet structure. An outlet manifold is generally designed to ensure that peak flows can be conveyed to the outlet structure.

To drain the system completely, an underdrain system is located at or below the bottom of the foundation stone. Some beds may be designed with a pitched base to ensure complete drainage of the system. A grade of 1/2% is usually satisfactory.

An outlet pipe may be located at a higher invert within a bed. This allows a designed volume of water to infiltrate while excess volumes are outlet as necessary. This is an excellent method of recharging groundwater, replicating a site's pre-construction hydraulics.

Depending on the bed layout and inverts, outlet pipes should be placed in the embedment stone along the bed's perimeter as shown in **Figures 8 and 9**. Solid outlet pipes should also be used to penetrate the StormTech end caps at the designed outlet invert as shown in **Figure 10**. An Isolator Row PLUS should not be directly penetrated with an outlet pipe. For systems requiring higher outlet flow rates, a combination of connections may be utilized as shown in **Figure 11**.

In detention and retention applications the discharge of water from the stormwater management system is determined based on the hydrology of the area and the hydraulic design of the system. It is the design engineer's responsibility to design an outlet system that meets their hydraulic objectives while following local laws and regulations.

**Table 9B - Maximum Outlet Flow Rate Capacities from StormTech Manifolds**

Outlet Flow		
Pipe Diameter	Flow (CFS)	Flow (L/S)
6 (150 mm)	0.4	11.3
8 (200 mm)	0.7	19.8
10 (250 mm)	1.0	28.3
12 (300 mm)	2.0	56.6
15 (375 mm)	2.7	76.5
18 (450 mm)	4.0	113.3
24 (600 mm)	7.0	198.2
30 (750 mm)	11.0	311.5
36 (900 mm)	16.0	453.1
42 (1050 mm)	22.0	623.0
48 (1200 mm)	28.0	792.9

**Figure 8 - Underdrain Parallel**

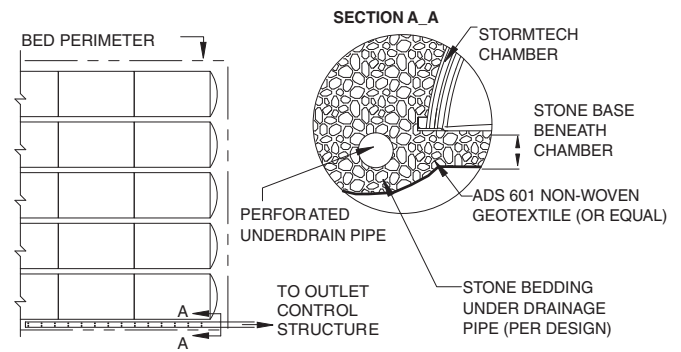

**Figure 9 - Underdrain Perpendicular**

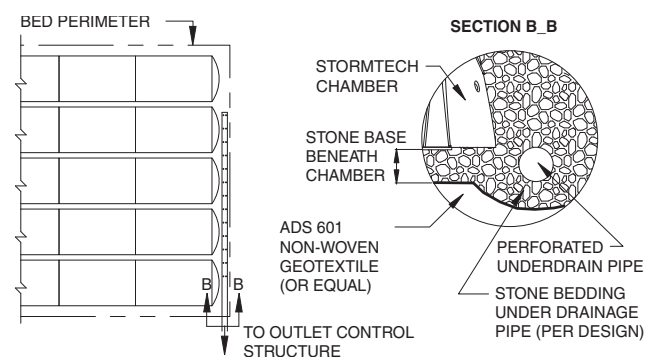

**Figure 10 - Outlet Manifold**

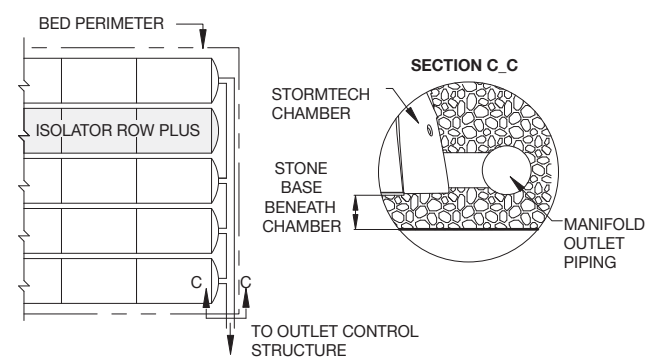

**Figure 11 - Combination Outlet**

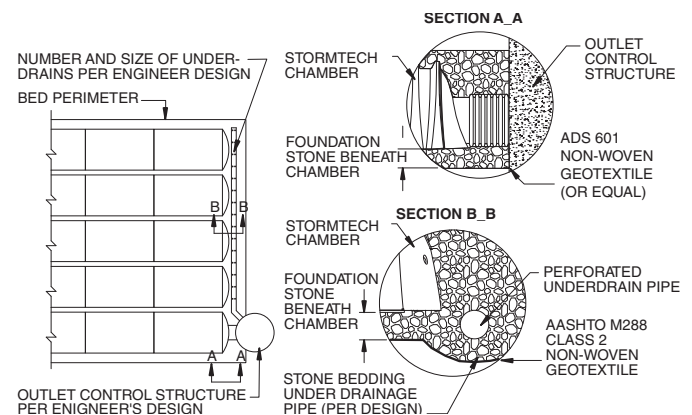

## 9.0 Other Considerations

### 9.1 Erosion Control

Erosion and sediment control measures must be integrated into the plan to protect the stormwater system both during and after construction. These practices may have a direct impact on the system's infiltration performance and longevity. Vegetation, temporary sediment barriers (silt fences, hay bales, fabric-wrapped catch basin grates), and strategic stormwater runoff management may be used to control erosion and sedimentation. StormTech recommends the use of pipe plugs on the inlet pipe until the system is in service.

### 9.2 SITE IMPROVEMENT TECHNIQUES

When site conditions are less than optimal, StormTech recognizes many methods for improving a site for construction. Some techniques include the removal and replacement of poor materials, the use of engineered subgrade materials, aggregates, chemical treatment, and mechanical treatments including the use of geosynthetics. StormTech recommends referring to AASHTO M 288 guidelines for the appropriate use of geotextiles.

StormTech also recognizes geogrid as a potential component of an engineered solution to improve site conditions or as a construction tool for the experienced contractor. StormTech chamber systems are compatible with the use of geosynthetics. The use of geosynthetics or any other site improvement method does not eliminate or modify any of StormTech's requirements. **It is the ultimate responsibility of the design engineer to ensure that site conditions are suitable for a StormTech chamber system.**

### 9.3 CONFORMING TO SITE CONSTRAINTS

StormTech chambers have the unique ability to conform to site constraints such as utility lines, light posts, etc. Rows of chambers can be ended short or interrupted by placing an end cap at the desired location, leaving the required number of chambers out of the row to get by the obstruction, then starting the row of chambers again with another end cap. See **Figure 12** for an example.

**Figure 12 - Ability to Conform to Site Constraints**

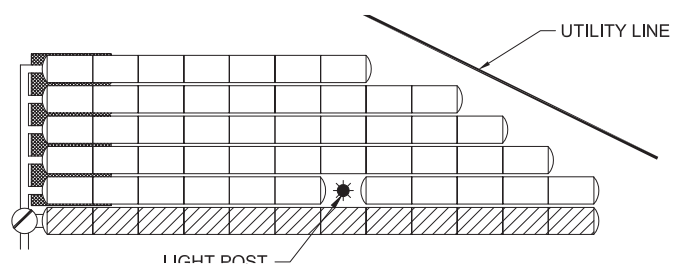

### 9.4 LINERS

StormTech chambers offer the distinct advantage and versatility that allow them to be designed as an open bottom detention or retention system. In fact, the vast majority of StormTech installations and designs are open bottom detention systems. Using an open bottom system enables treatment of the storm water through the underlying soils and provides a volume safety factor based on the infiltrative capacity of the underlying soils.

In some applications, however, open bottom detention systems may not be allowed. StormTech's Tech Sheet #2 provides guidance for the design and installation of thermoplastic liners for detention systems using StormTech chambers. The major points of the memo are:

- Infiltration of stormwater is generally a desirable stormwater management practice, often required by regulations. Lined systems should only be specified where unique site conditions preclude significant infiltration.
- Thermoplastic liners provide cost effective and viable means to contain stormwater in StormTech subsurface systems where infiltration is undesirable.
- PVC and LLDPE are the most cost effective, installed membrane materials.
- Enhanced puncture resistance from angular aggregate on the water side and from protrusions on the soil side can be achieved by placing a non-woven geotextile reinforcement on each side of the geomembrane. A sand underlayment in lieu of the geotextile reinforcement on the soil side may be considered when cost effective.
- StormTech does not design, fabricate, sell or install thermoplastic liners. StormTech recommends consulting with liner professionals for final design and installation advice.

**Figure 13 - Chamber bed placed around light post.**

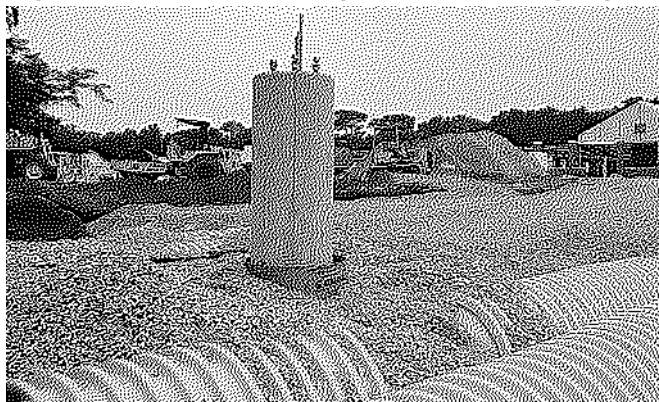

# 10.0 System Sizing

For quick calculations, refer to the Site Calculator on StormTech’s website at [www.adspipe.com/stormtech](http://www.adspipe.com/stormtech).

## 10.1 System Sizing

The following steps provide the calculations necessary to size a system. If you need assistance determining the number of chambers per row or customizing the bed configuration to fit a specific site, call StormTech’s Technical Services Department at 1-888-892-2694.

### 1) Determine the amount of storage volume ( $V_s$ ) required.

It is the design engineer’s sole responsibility to determine the storage volume required by local

**Table 10 - Storage Volume Per Chamber**

	Bare Chamber Storage ft <sup>3</sup> (m <sup>3</sup> )	Chamber and Stone Foundation Depth in. (mm)		
		6 (150)	12 (300)	18 (450)
SC-160LP	6.85 (0.19)	16 (0.42)	18.9 (0.51)	21.9 (0.6)
SC-310	14.7 (0.4)	31 (0.9)	35.7 (1)	40.4 (1.1)
SC-740	45.9 (1.3)	74.9 (2.1)	81.6 (2.3)	88.4 (2.5)
SC-800	50.6 (1.4)	81 (2.3)	87.8 (2.4)	94.6 (2.6)
	ft <sup>3</sup> (m <sup>3</sup> )	9 (230)	12 (300)	18 (450)
DC-780	46.2 (1.3)	78.4 (2.2)	81.8 (2.3)	88.6 (2.5)

Note: Assumes 40% porosity for the stone plus the chamber volume.

codes.

### 2) Determine the number of chambers (C) required.

To calculate the number of chambers needed for adequate storage, divide the storage volume ( $V_s$ ) by the volume of the selected chamber, as follows:

$$C = V_s / \text{Volume per Chamber}$$

### 3) Determine the required bed size (S).

To find the size of the bed, multiply the number of chambers needed (C) by either:

#### StormTech SC-160LP

bed area per chamber = 14.8 ft<sup>2</sup> (1.3 m<sup>2</sup>)

#### StormTech SC-310

bed area per chamber = 23.7 ft<sup>2</sup> (2.2 m<sup>2</sup>)

#### StormTech SC-740 / DC-780 / SC-800

bed area per chamber = 33.8 ft<sup>2</sup> (3.1 m<sup>2</sup>)

$$S = (C \times \text{bed area per chamber}) + [1 \text{ foot (0.3 m)} \times \text{bed perimeter in feet (meters)}]$$

NOTE: It is necessary to add one foot (0.3 m) around the perimeter of the bed for end caps and working space.

### 4) Determine the amount of clean, crushed, angular stone ( $V_{st}$ ) required.

To calculate the total amount of clean, crushed, angular stone required, multiply the number of chambers (C) by the selected weight of stone from **Table 11**.

**Table 11 – Amount of Stone Per Chamber**

ENGLISH tons (yd <sup>3</sup> )	Stone Foundation Depth		
	6	12	18
SC-160LP	1.3 (0.9)	1.7 (1.2)	2 (1.4)
SC-310	2.3 (1.6)	2.8 (2)	3.4 (2.4)
SC-740	3.8 (2.7)	4.8 (3.4)	5.6 (4)
SC-800	4.1 (2.9)	4.9 (3.5)	5.8 (4.1)
METRIC kg (m <sup>3</sup> )	150 mm	300 mm	450 mm
SC-160LP	1162 (0.7)	1495 (0.9)	1827 (1.1)
SC-310	1993 (1.2)	2491 (1.5)	3156 (1.9)
SC-740	3488 (2.1)	4319 (2.6)	5149 (3.1)
SC-800	3654 (2.2)	4485 (2.7)	5315 (3.2)
ENGLISH tons (yd <sup>3</sup> )	9	12	18
DC-780	4.2 (3)	4.7 (3.3)	5.6 (4)
METRIC kg (m <sup>3</sup> )	230 mm	300 mm	450 mm
DC-780	3986 (2.4)	4319 (2.6)	5149 (3.1)

Note: Assumes 6 (150 mm) of stone above, and between chambers. For SC-310, SC-740, DC-780 and SC-800 Chambers only.

NOTE: Clean, crushed, angular stone is also required around the perimeter of the system.

### 5) Determine the volume of excavation (Ex) required.

### 6) Determine the area of filter fabric (F) required.

Each additional foot of cover will add a volume of excavation of 1.3 yds<sup>3</sup> (1.0 m<sup>3</sup>) per SC-740 / DC-780 / SC-800, 0.9 yds<sup>3</sup> (0.7 m<sup>3</sup>) per SC-310 chamber and 0.55 yds<sup>3</sup> (0.4m<sup>3</sup>) per SC-160LP chamber.

**Table 12 – Volume of Excavation Per Chamber**

	Stone Foundation Depth yd <sup>3</sup> (m <sup>3</sup> )		
	6 (150 mm)	12 (300 mm)	18 (450 mm)
SC-160LP	1.6 (1.3)	1.9 (1.5)	2.2 (1.7)
SC-310	2.9 (2.2)	3.4 (2.6)	3.8 (2.9)
SC-740	5.6 (4.3)	6.3 (4.8)	6.9 (5.3)
SC-800	5.9 (4.5)	6.6 (5.0)	7.2 (5.5)
	9 (230 mm)	12 (300 mm)	18 (450 mm)
DC-780	5.9 (4.6)	6.3 (4.8)	6.9 (5.3)

Note: Assumes 6" (150 mm) of separation between chamber rows (no spacing for the SC-160LP) and 18" (450 mm) of cover. The volume of excavation will vary as the depth of the cover increases.

The bottom and sides of the bed and the top of the embedment stone must be covered with ADS 601 (or equal) a non-woven geotextile (filter fabric). The area of the sidewalls must be calculated and a 2 foot (0.6 m) overlap must be included where two pieces of filter fabric are placed side-by-side or end-to-end. Geotextiles typically come in 15 foot (4.6 m) wide rolls.

### 7) Determine the number of end caps ( $E_c$ ) required.

Each row of chambers requires two end caps.

$$E_c = \text{number of rows} \times 2$$

# 11.0 Detail Drawings

**Figure 14 – 4" (100 mm) PVC Inspection Port Detail (SC Series Chamber)**

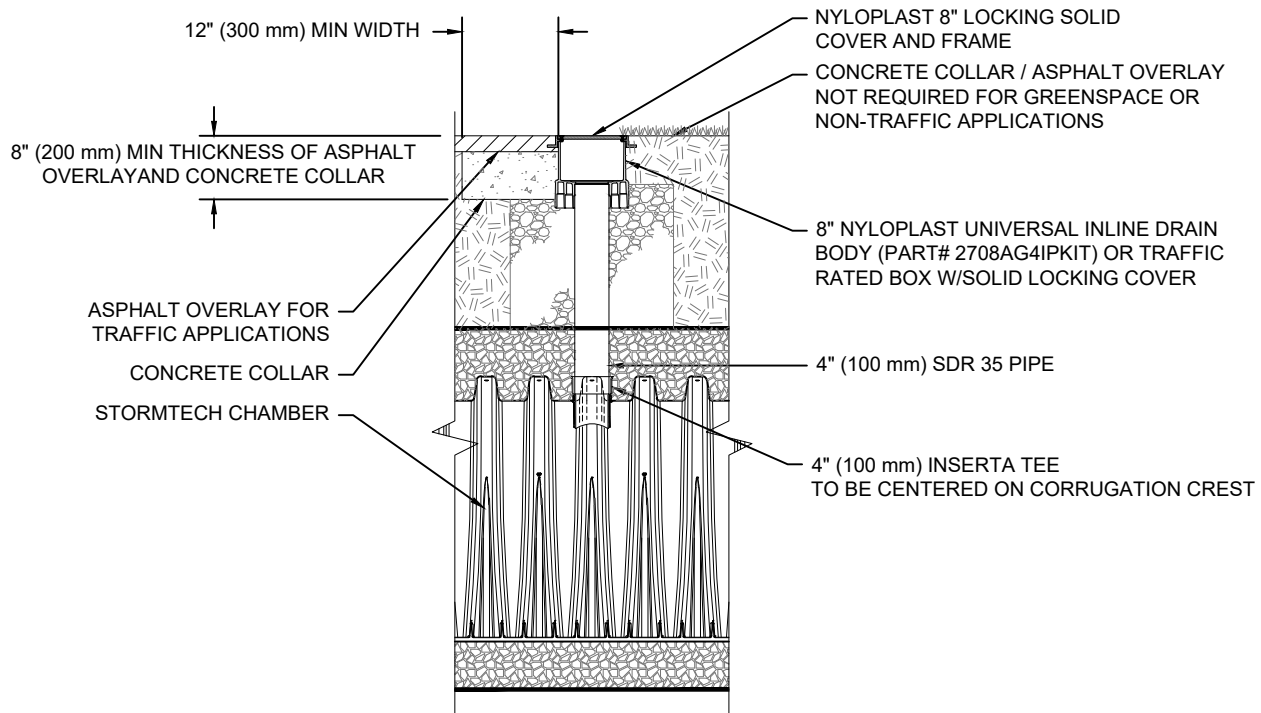

NOTE:  
INSPECTION PORTS MAY BE CONNECTED THROUGH ANY CHAMBER CORRUGATION CREST.

**Figure 15 – 6" (150 mm) Inspection Port Detail**

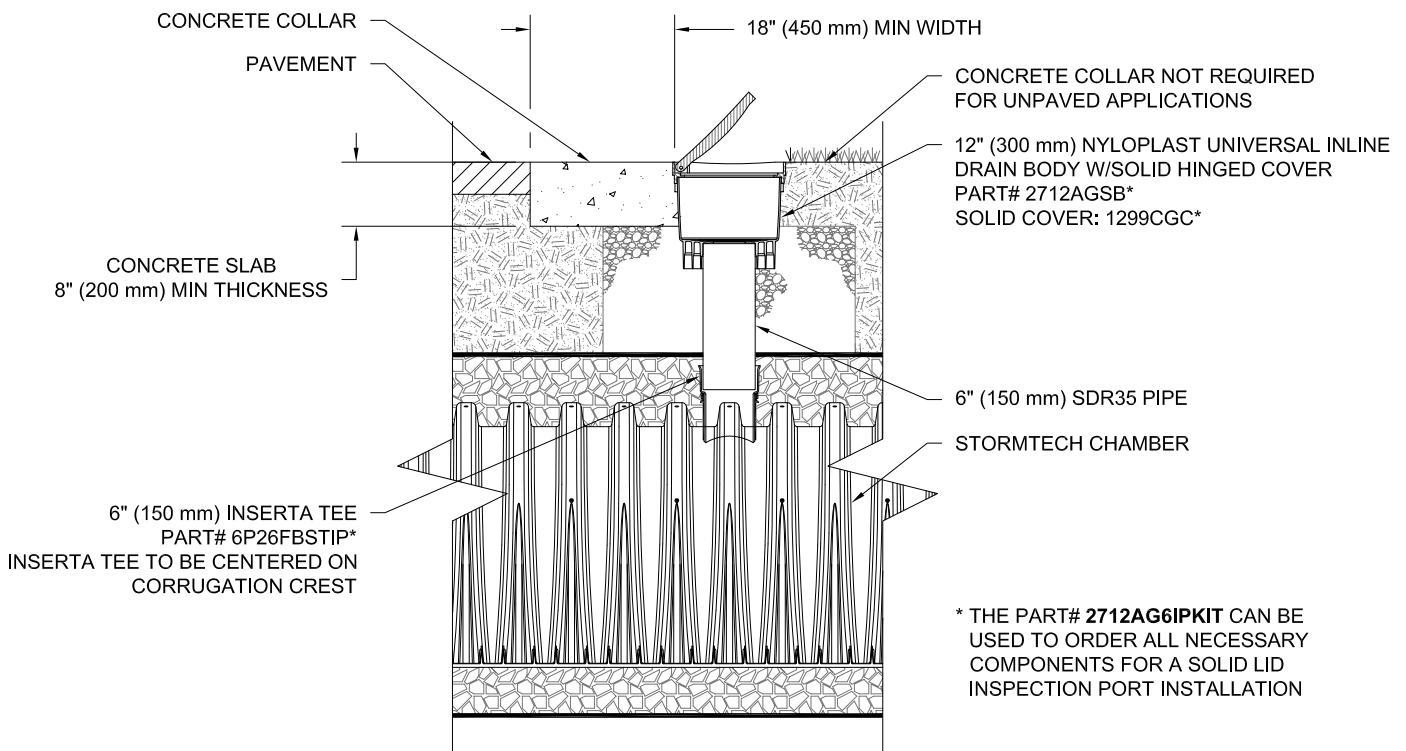

\* THE PART# 2712AG6IPKIT CAN BE USED TO ORDER ALL NECESSARY COMPONENTS FOR A SOLID LID INSPECTION PORT INSTALLATION

# 11.0 Detail Drawings

**Figure 16 – Under Drain Detail**

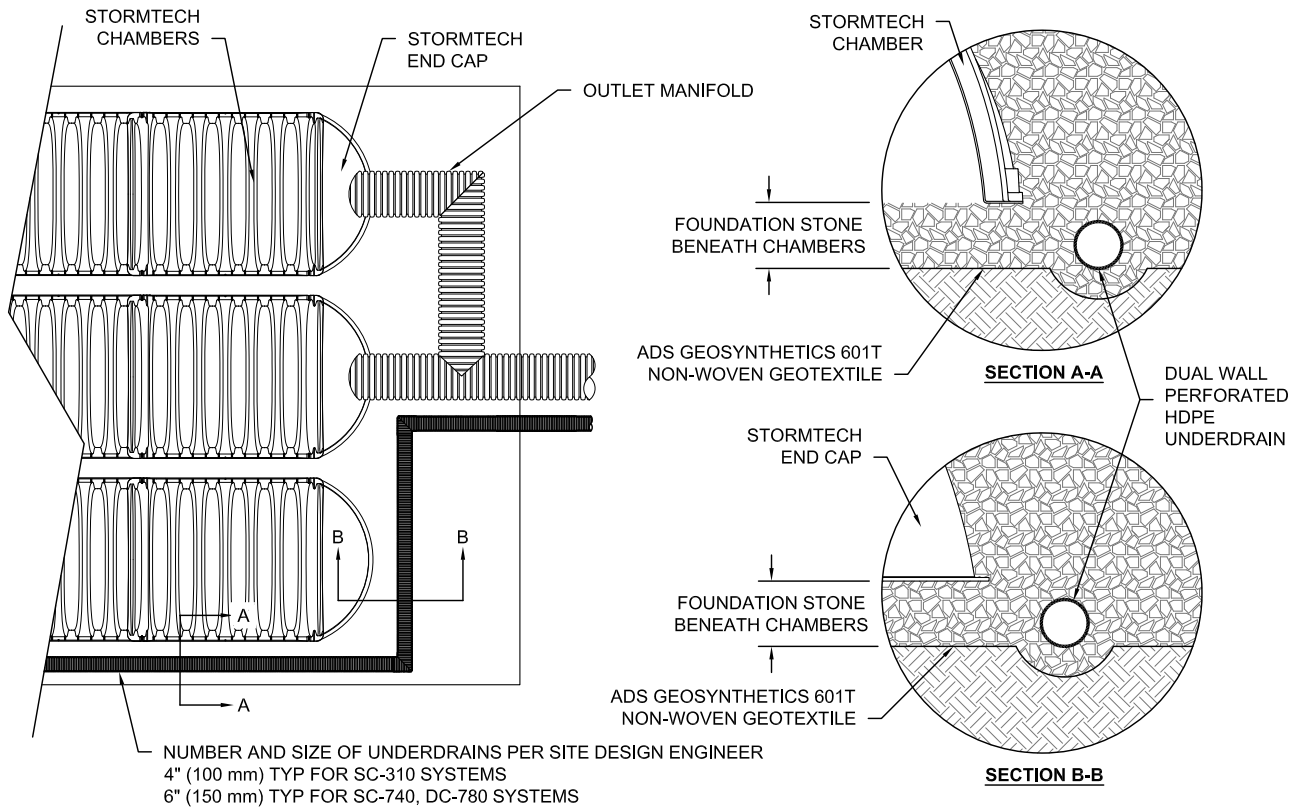

**Figure 17 – Inserta Tee Side Detail**

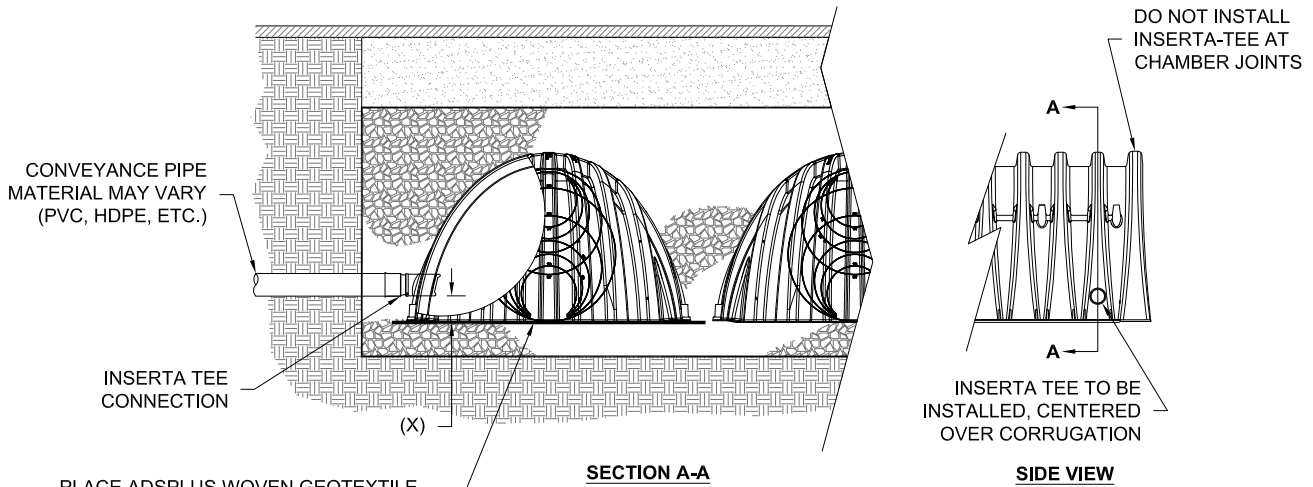

PLACE ADSPLUS WOVEN GEOTEXTILE (CENTERED ON INSERTA-TEE INLET) OVER BEDDING STONE FOR SCOUR PROTECTION AT SIDE INLET CONNECTIONS. GEOTEXTILE MUST EXTEND 6" (150 mm) PAST CHAMBER FOOT

**NOTES:**

- PART NUMBERS WILL VARY BASED ON INLET PIPE MATERIALS. CONTACT STORMTECH FOR MORE INFORMATION.
- CONTACT ADS ENGINEERING SERVICES IF INSERTA TEE INLET MUST BE RAISED AS NOT ALL INVERTS ARE POSSIBLE.

CHAMBER	MAX DIAMETER OF INSERTA TEE	HEIGHT FROM BASE OF CHAMBER (X)
SC-310	6" (150 mm)	4" (100 mm)
SC-740	10" (250 mm)	4" (100 mm)
SC-800	10" (250 mm)	4" (100 mm)
DC-780	10" (250 mm)	4" (100 mm)

INSERTA TEE FITTINGS AVAILABLE FOR SDR 26, SDR 35, SCH 40 IPS GASKETED & SOLVENT WELD, N-12, HP STORM, C-900 OR DUCTILE IRON

**NOTE:** Side Inserta Tees Cannot be used on SC-160LP Chambers.

## 12.0 Inspection and Maintenance

### 12.1 Isolator Row Plus Inspection

Regular inspection and maintenance are essential to assure a properly functioning stormwater system. Inspection is easily accomplished through the manhole or optional inspection ports of an Isolator Row PLUS. Please follow local and OSHA rules for a confined space entry.

Inspection ports can allow inspection to be accomplished completely from the surface without the need for a confined space entry. Inspection ports provide visual access to the system with the use of a flashlight. A stadia rod may be inserted to determine the depth of sediment. If upon visual inspection it is found that sediment has accumulated to an average depth exceeding 3" (75 mm), cleanout is required.

A StormTech Isolator Row PLUS should initially be inspected immediately after completion of the site's construction. While every effort should be made to prevent sediment from entering the system during construction, it is during this time that excess amounts of sediments are most likely to enter any stormwater system. Inspection and maintenance, if necessary, should be performed prior to passing responsibility over to the site's owner. Once in normal service, a StormTech Isolator Row PLUS should be inspected bi-annually until an understanding of the sites characteristics is developed. The site's maintenance manager can then revise the inspection schedule based on experience or local requirements.

### 12.2 Isolator Row Plus Maintenance

JetVac maintenance is recommended if sediment has been collected to an average depth of 3" (75 mm) inside the Isolator Row PLUS. More frequent maintenance may be required to maintain minimum flow rates through the Isolator Row PLUS. The JetVac process utilizes a high pressure water nozzle to propel itself down the Isolator Row PLUS while scouring and suspending sediments. As the nozzle is retrieved, a wave of suspended sediments is flushed back into the manhole for vacuuming. Most sewer and pipe maintenance companies have vacuum/ JetVac combination vehicles. Fixed nozzles designed for culverts or large diameter pipe cleaning are preferable. Rear facing jets with an effective spread of at least 45" (1125 mm) are best. StormTech recommends a maximum nozzle pressure of 2000 psi be utilized during cleaning. The JetVac process shall only be performed on StormTech Rows that have ADS PLUS fabric over the foundation stone.



Looking down the Isolator Row PLUS



A typical JetVac truck (This is not a StormTech product.)

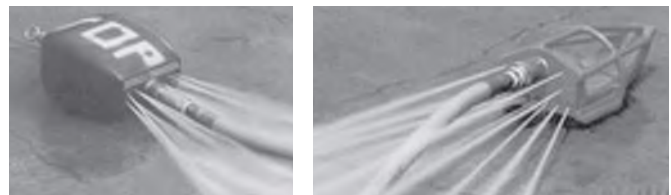

Examples of culvert cleaning nozzles appropriate for Isolator Row PLUS maintenance. (These are not StormTech products).

# 12.0 Inspection & Maintenance

## StormTech Isolator Row Plus - Step-by-Step Maintenance Procedures

**Step 1:** Inspect Isolator Row PLUS for sediment

- A) Inspection ports (if present)
  - i. Remove lid from floor box frame
  - ii. Remove cap from inspection riser
  - iii. Using a flashlight and stadia rod, measure depth of sediment
  - iv. If sediment is at, or above, 3" (76 mm) depth proceed to Step 2. If not proceed to Step 3.
- B) All Isolator Plus Rows
  - i. Remove cover from manhole at upstream end of Isolator Row PLUS
  - ii. Using a flashlight, inspect down Isolator Row PLUS through outlet pipe
    - 1. Follow OSHA regulations for confined space entry if entering manhole
    - 2. Mirrors on poles or cameras may be used to avoid a confined space entry
  - iii. If sediment is at or above the lower row of sidewall holes [approximately 3" (76 mm)] proceed to Step 2. If not proceed to Step 3.

**Step 2:** Clean out Isolator Row PLUS using the JetVac process

- A) A fixed floor cleaning nozzle with rear facing nozzle spread of 45" (1125 mm) or more is preferable
- B) Apply multiple passes of JetVac until backflush water is clean
- C) Vacuum manhole sump as required during jetting

**Step 3:** Replace all caps, lids and covers

**Step 4:** Inspect and clean catch basins and manholes upstream of the StormTech system following local guidelines.

**Figure 18 - StormTech Isolator Row Plus (not to scale)**

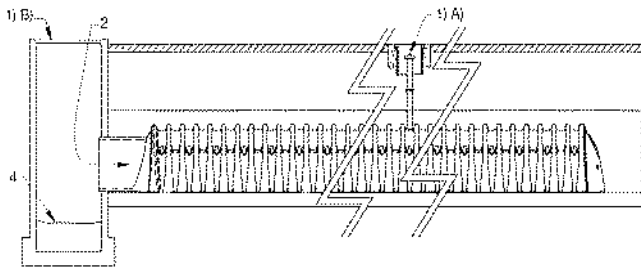

## 12.3 Eccentric Pipe Header Inspection

These guidelines do not supercede a pipe manufacturer's recommended I&M procedures. Consult with the manufacturer of the pipe header system for specific I&M procedures. Inspection of the header system should be carried out quarterly. On sites which generate higher levels of sediment more frequent inspections may be necessary. Headers may be accessed through risers, access ports or manholes. Measurement of sediment may be taken with a stadia rod or similar device. Cleanout of sediment should occur when the sediment volume has reduced the storage area by 25% or the depth of sediment has reached approximately 25% of the diameter of the structure.

## 12.4 Eccentric Pipe Manifold Maintenance

Cleanout of accumulated material should be accomplished by vacuum pumping the material from the header. Cleanout should be accomplished during dry weather. Care should be taken to avoid flushing sediments out through the outlet pipes and into the chamber rows.

## Eccentric Header Step-by-Step Maintenance Procedures

1. Locate manholes connected to the manifold system
2. Remove grates or covers
3. Using a stadia rod, measure the depth of sediment
4. If sediment is at a depth of about 25% pipe volume or 25% pipe diameter proceed to step 5. If not proceed to step 6.
5. Vacuum pump the sediment. Do not flush sediment out inlet pipes.
6. Replace grates and covers
7. Record depth and date and schedule next inspection

**Figure 19 - Eccentric Manifold Maintenance**

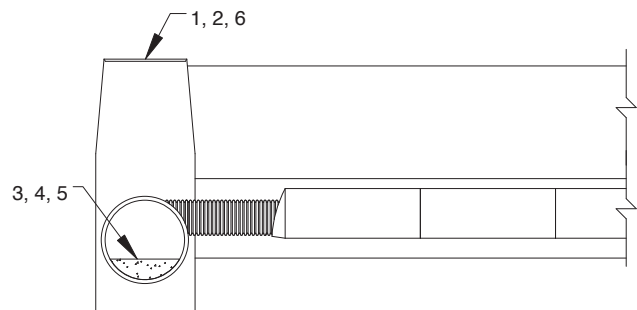

Please contact StormTech's Technical Services Department at 888-892-2894 for a spreadsheet to estimate cleaning intervals.

## 13.0 General Notes

1. StormTech requires installing contractors to use and understand StormTech's latest Installation Instructions prior to beginning system installation.
2. Our Technical Services Department offers installation consultations to installing contractors. Contact our Technical Service Representatives at least 30 days prior to system installation to arrange a preinstallation consultation. Our representatives can then answer questions or address comments on the StormTech chamber system and inform the Installing contractor of the minimum installation requirements before beginning the system's construction. Call **800-821-6710** to speak to a Technical Service Representative or visit **[www.adspipe.com/stormtech](http://www.adspipe.com/stormtech)** to receive a copy of our Installation Instructions.
3. StormTech's requirements for systems with pavement design (asphalt, concrete pavers, etc.): Minimum cover for the SC-740, DC-780 and SC-310 chambers is 18" (457 mm) not including pavement; Minimum cover for the SC-160LP chamber is 14 (350 mm); Minimum Cover for the SC-800 chamber is 15" (381 mm); Maximum cover for the SC-800, SC-740 and SC-310 chambers is 96" (2.4 m) including pavement design; Maximum cover for the SC-160LP chamber is 10' (3.0 m); Maximum cover for the DC-780 chamber is 12' (3.6 m) including pavement design. For installations that do not include pavement, where rutting from vehicles may occur, minimum required cover is 24" (610 mm), maximum cover is as stated above.
4. The contractor must report any discrepancies with the bearing capacity of the chamber foundation materials to the design engineer.
5. AASHTO M288 Class 2 non-woven geotextile (filter fabric) must be used as indicated in the project plans.
6. Stone placement between chamber rows and around perimeter must follow instructions as indicated in the most current version of StormTech's Installation Instructions.
7. Backfilling over the chambers must follow requirements as indicated in the most current version of StormTech's Installation Instructions.
8. The contractor must refer to StormTech's Installation Instructions for a Table of Acceptable Vehicle Loads at various depths of cover. This information is also available at StormTech's website: **[www.adspipe.com/stormtech](http://www.adspipe.com/stormtech)**. The contractor is responsible for preventing vehicles that exceed StormTech's requirements from traveling across or parking over the stormwater system. Temporary fencing, warning tape and appropriately located signs are commonly used to prevent unauthorized vehicles from entering sensitive construction areas.
9. The contractor must apply erosion and sediment control measures to protect the stormwater system during all phases of site construction per local codes and design engineer's specifications.
10. STORMTECH PRODUCT WARRANTY IS LIMITED. Contact StormTech for warranty information.

# 14.0 StormTech Product Specifications

## 1.0 General

1.1 StormTech chambers are designed to control storm water runoff. As a subsurface retention system, StormTech chambers retain and allow effective infiltration of water into the soil. As a subsurface detention system, StormTech chambers detain and allow for the metered flow of water to an outfall.

## 2.0 Chamber Parameters

- 2.1 The Chamber shall be injection molded of an impact modified polypropylene or polyethylene copolymer to maintain adequate stiffness through higher temperatures experienced during installation and service.
- 2.2 The nominal chamber dimensions of the SC-800 shall be 33.0" (838 mm) tall, 51" (1295 mm) wide, and 90.7" (2304 mm) long. The nominal chamber dimensions of the StormTech SC-740 and DC-780 shall be 30.0 (762 mm) tall, 51.0 (1295 mm) wide and 90.7 (2304 mm) long. The nominal chamber dimensions of the StormTech SC-310 shall be 16.0 (406 mm) tall, 34.0 (864 mm) wide and 90.7 (2304 mm) long. SC-160LP shall be 12(305mm) tall, 25 (635 mm) wide and 90.7 (2304mm) long. The installed length of a joined chamber shall be 85.4 (2169 mm).
- 2.3 The chamber shall have a continuously curved section profile.
- 2.4 The chamber shall be open-bottomed.
- 2.5 The chamber shall incorporate an overlapping corrugation joint system to allow chamber rows of almost any length to be created. The overlapping corrugation joint system shall be effective while allowing a chamber to be trimmed to shorten its overall length.
- 2.6 The nominal storage volume of all StormTech chambers includes the volume of the clean, crushed, angular stone with an assumed 40% porosity. The nominal storage volume of a joined StormTech SC-800 chamber shall be 81.0 ft<sup>3</sup> (2.29 m<sup>3</sup>) per chamber when installed per StormTech's typical details. This equates to a storage volume per unit area of bed of 2.39 ft<sup>3</sup>/ft<sup>2</sup> (0.72 m<sup>3</sup>/m<sup>2</sup>). The nominal storage volume of a joined StormTech SC-740 chamber shall be 74.9 ft<sup>3</sup> (2.1 m<sup>3</sup>) per chamber when installed per StormTech's typical details. This equates to a storage volume per unit area of bed of 2.2 ft<sup>3</sup>/ft<sup>2</sup> (0.67 m<sup>3</sup>/m<sup>2</sup>). The nominal storage volume of a joined StormTech DC-780 chamber shall be 78.4 ft<sup>3</sup> (2.2 m<sup>3</sup>) per chamber when installed per StormTech's typical details. This equates to a

storage volume per unit area of bed of 2.3 ft<sup>3</sup>/ft<sup>2</sup> (0.70 m<sup>3</sup>/m<sup>2</sup>). The nominal storage volume of a joined StormTech SC-310 chamber shall be 31.0 ft<sup>3</sup> (0.88 m<sup>3</sup>) per chamber when installed per StormTech's typical details. This equates to a storage volume per unit area of bed of 1.3 ft<sup>3</sup>/ft<sup>2</sup> (0.40 m<sup>3</sup>/m<sup>2</sup>). The nominal storage volume of a joined StormTech SC-160LP chamber shall be 15 ft<sup>3</sup> (0.42 m<sup>3</sup>) per chamber when installed per StormTech's typical details. This equates to a storage volume per unit area of bed of 1.0 ft<sup>3</sup>/ft<sup>2</sup> (0.30 m<sup>3</sup>/m<sup>2</sup>).

- 2.7 The chamber shall have two orifices near its top to allow for equalization of air pressure between its interior and exterior.
- 2.8 The chamber shall have both of its ends open to allow for unimpeded hydraulic flows and visual inspections down a row's entire length.
- 2.9 The chamber shall have 14 corrugations.
- 2.10 The chamber shall be analyzed and designed using AASHTO methods for thermoplastic culverts contained in the LRFD Bridge Design Specifications, 2<sup>nd</sup> Edition, including Interim Specifications through 2001. Design live load shall be the AASHTO design truck. Design shall consider earth and live loads as appropriate for the minimum to maximum specified depth of fill.
- 2.11 The chamber shall be manufactured in an ISO 9001:2000 certified facility.

## 3.0 End Cap Parameters

- 3.1 The end cap shall be designed to fit into any corrugation of a chamber, which allows: capping a chamber that has its length trimmed; segmenting rows into storage basins of various lengths.
- 3.2 The end cap shall have saw guides to allow easy cutting for various diameters of pipe that may be used to inlet the system.
- 3.3 The end cap shall have excess structural adequacies to allow cutting an orifice of any size at any invert elevation.
- 3.4 The primary face of an end cap shall be curved outward to resist horizontal loads generated near the edges of beds.
- 3.5 The end cap shall be manufactured in an ISO 9001:2000 certified facility.

# 15.0 Chamber Specifications for Contract Documents

## SC-800 StormTech Chamber Specifications

1. Chambers shall be Stormtech SC-800.
2. Chambers shall be arch-shaped and shall be manufactured from virgin, impact-modified polypropylene copolymers.
3. Chambers shall meet the requirements of ASTM F2418-16A, Standard Specification for Polypropylene (PP) Corrugated Wall Stormwater Collection Chambers
4. Chamber rows shall provide continuous, unobstructed internal space with no internal supports that would impede flow or limit access for inspection.
5. The structural design of the chambers, the structural backfill, and the installation requirements shall ensure that the load factors specified in the AASHTO LRFD bridge design specifications, Section 12.12, are met for: 1) long-duration dead loads and 2) short-duration live loads, based on the AASHTO design truck with consideration for impact and multiple vehicle presences.
6. Chambers shall be designed, tested and allowable load configurations determined in accordance with ASTM F2787, Standard practice for structural design of Thermoplastic Corrugated Wall Stormwater Collection Chambers. Load configurations shall include: 1) instantaneous (<1 min) AASHTO design truck live load on minimum cover 2) maximum permanent (75-yr) cover load and 3) allowable cover with parked (1-week) AASHTO design truck.
7. Requirements for handling and installation:
  - To maintain the width of chambers during shipping and handling, chambers shall have integral, interlocking stacking lugs.
  - To ensure a secure joint during installation and backfill, the height of the chamber joint shall not be less than 2.
8. Only chambers that are approved by the site design engineer will be allowed. The chamber manufacturer shall submit the following upon request to the site design engineer for approval before delivering chambers to the project site:
  - To ensure the integrity of the arch shape during installation, a) the arch stiffness constant as defined in Section 6.2.8 of ASTM F2418 shall be greater than or equal to 550 lbs/in/in. And b) to resist softening during hot, sunny installation conditions, chambers shall be produced from light, reflective gold or yellow colors.
  - A structural evaluation sealed by a registered professional engineer that demonstrates that the safety factors are greater than or equal to 1.95 for dead load and 1.75 for live load, the minimum required by ASTM F2787 and by AASHTO for thermoplastic pipe.
  - A structural evaluation sealed by a registered professional engineer that demonstrates that the load factors specified in the AASHTO LRDF bridge design specifications, Section 12.12, are met. The 50 year creep modulus data specified in ASTM F2418 must be used as part of the AASHTO structural evaluation to verify long-term performance.

Chambers and end caps shall be produced at an ISO 9001 certified manufacturing facility.

**APPENDIX D-2**  
**STORMTECH ISOLATOR ROW PLUS**  
**MANUAL**

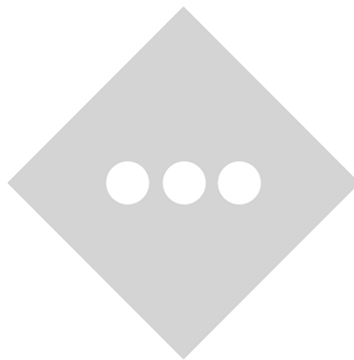

# Isolator<sup>®</sup> Row Plus

## O&M Manual

---



# The Isolator<sup>®</sup> Row Plus

## Introduction

An important component of any Stormwater Pollution Prevention Plan is inspection and maintenance. The StormTech Isolator Row Plus is a technique to inexpensively enhance Total Suspended Solids (TSS), Total Phosphorus (TP), Total Petroleum Hydrocarbons (TPH) and Total Nitrogen (TN) removal with easy access for inspection and maintenance.

## The Isolator Row Plus

The Isolator Row Plus is a row of StormTech chambers, either SC-160, SC-310, SC-310-3, SC-740, DC-780, SC-800, MC-3500, MC-4500 or MC-7200 models, are lined with filter fabric and connected to a closely located manhole for easy access. The fabric lined chambers provide for sediment settling and filtration as stormwater rises in the Isolator Row Plus and passes through the filter fabric. The open bottom chambers allow stormwater to flow vertically out of the chambers. Sediments are captured in the Isolator Row Plus protecting the adjacent stone and chambers storage areas from sediment accumulation.

ADS Isolator Row and Plus fabric are placed between the stone and the Isolator Row Plus chambers. The woven geotextile provides a media for stormwater filtration, a durable surface for maintenance, prevents scour of the underlying stone and remains intact during high pressure jetting.

The Isolator Row Plus is designed to capture the “first flush” runoff and offers the versatility to be sized on a volume basis or a flow-rate basis. An upstream manhole provides access to the Isolator Row Plus and includes a high/low concept such that stormwater flow rates or volumes that exceed the capacity of the Isolator Row Plus bypass through a manifold to the other chambers. This is achieved with an elevated bypass manifold or a high-flow weir. This creates a differential between the Isolator Row Plus row of chambers and the manifold to the rest of the system, thus allowing for settlement time in the Isolator Row Plus. After Stormwater flows through the Isolator Row Plus and into the rest of the chamber system it is either exfiltrated into the soils below or passed at a controlled rate through an outlet manifold and outlet control structure.

The Isolator Row Plus Flamp™ is a flared end ramp apparatus attached to the inlet pipe on the inside of the chamber end cap. The FLAMP provides a smooth transition from pipe invert to fabric bottom. It is configured to improve chamber function performance by enhancing outflow of solid debris that would otherwise collect at the chamber's end, or more difficult to remove and require confined space entry into the chamber area. It also serves to improve the fluid and solid flow into the access pipe during maintenance and cleaning and to guide cleaning and inspection equipment back into the inlet pipe when complete.

The Isolator Row Plus may be part of a treatment train system. The treatment train design and pretreatment device selection by the design engineer is often driven by regulatory requirements. Whether pretreatment is used or not, StormTech recommend using the Isolator Row Plus to minimize maintenance requirements and maintenance costs.

**Note:** See the StormTech Design Manual for detailed information on designing inlets for a StormTech system, including the Isolator Row Plus.



Looking down the Isolator Row Plus from the manhole opening, ADS Plus Fabric is shown between the chamber and stone base.

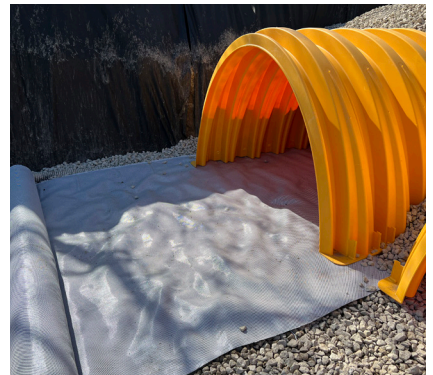

StormTech Isolator Row Plus with Overflow Structure (not to scale)

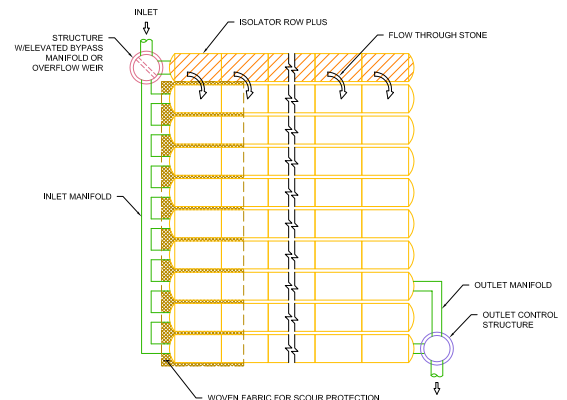

# Isolator Row Plus Inspection/Maintenance

## Inspection

The frequency of inspection and maintenance varies by location. A routine inspection schedule needs to be established for each individual location based upon site specific variables. The type of land use (i.e. industrial, commercial, residential), anticipated pollutant load, percent imperviousness, climate, etc. all play a critical role in determining the actual frequency of inspection and maintenance practices.

At a minimum, StormTech recommends annual inspections. Initially, the Isolator Row Plus should be inspected every 6 months for the first year of operation. For subsequent years, the inspection should be adjusted based upon previous observation of sediment deposition.

The Isolator Row Plus incorporates a combination of standard manhole(s) and strategically located inspection ports (as needed). The inspection ports allow for easy access to the system from the surface, eliminating the need to perform a confined space entry for inspection purposes.

If upon visual inspection it is found that sediment has accumulated, a stadia rod should be inserted to determine the depth of sediment. When the average depth of sediment exceeds 3" (75 mm) throughout the length of the Isolator Row Plus, clean-out should be performed.

## Maintenance

The Isolator Row Plus was designed to reduce the cost of periodic maintenance. By "isolating" sediments to just one row, costs are dramatically reduced by eliminating the need to clean out each row of the entire storage bed. If inspection indicates the potential need for maintenance, access is provided

via a manhole(s) located on the end(s) of the row for cleanout. If entry into the manhole is required, please follow local and OSHA rules for a confined space entry.

Maintenance is accomplished with the JetVac process. The JetVac process utilizes a high pressure water nozzle to propel itself down the Isolator Row Plus while scouring and suspending sediments. As the nozzle is retrieved, the captured pollutants are flushed back into the manhole for vacuuming. Most sewer and pipe maintenance companies have vacuum/JetVac combination vehicles. Selection of an appropriate JetVac nozzle will improve maintenance efficiency. Fixed nozzles designed for culverts or large diameter pipe cleaning are preferable. Rear facing jets with an effective spread of at least 45" are best. StormTech recommends a maximum nozzle pressure of 2000 psi be utilized during cleaning. JetVac reels can vary in length. For ease of maintenance, ADS recommends Isolator Row Plus lengths up to 200' (61 m). **The JetVac process shall only be performed on StormTech Isolator Row Plus that have ADS Plus Fabric (as specified by StormTech) over their angular base stone.**

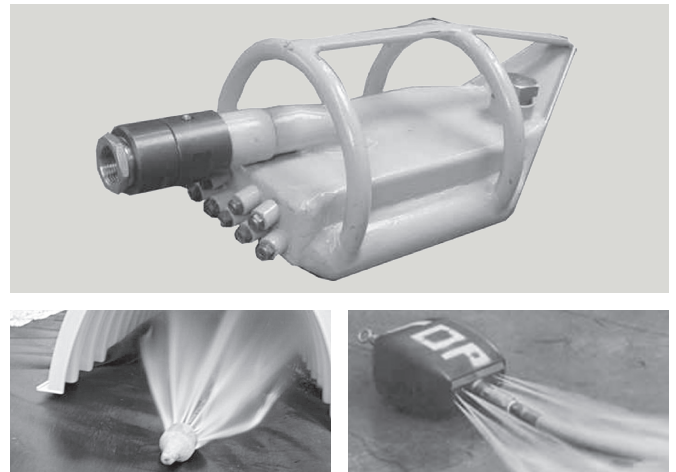

## StormTech Isolator Row Plus (not to scale)

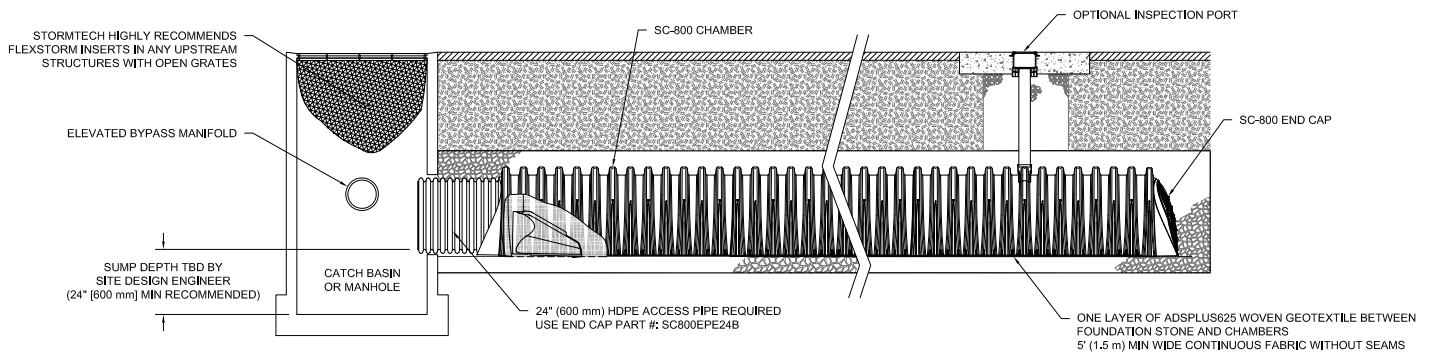

# Isolator Row Plus Step By Step Maintenance Procedures

## Step 1

Inspect Isolator Row Plus for sediment.

- A) Inspection ports (if present)
  - i. Remove lid from floor box frame
  - ii. Remove cap from inspection riser
  - iii. Using a flashlight and stadia rod, measure depth of sediment and record results on maintenance log.
  - iv. If sediment is at or above 3 inch depth, proceed to Step 2. If not, proceed to Step 3.
- B) All Isolator Row Plus
  - i. Remove cover from manhole at upstream end of Isolator Row Plus
  - ii. Using a flashlight, inspect down Isolator Row Plus through outlet pipe
    - 1. Mirrors on poles or cameras may be used to avoid a confined space entry
    - 2. Follow OSHA regulations for confined space entry if entering manhole
  - iii. If sediment is at or above the lower row of sidewall holes (approximately 3 inches), proceed to Step 2. If not, proceed to Step 3.

## Step 2

Clean out Isolator Row Plus using the JetVac process.

- A) A fixed floor cleaning nozzle with rear facing nozzle spread of 45 inches or more is preferable
- B) Apply multiple passes of JetVac until backflush water is clean
- C) Vacuum manhole sump as required

## Step 3

Replace all caps, lids and covers, record observations and actions.

## Step 4

Inspect & clean catch basins and manholes upstream of the StormTech system.

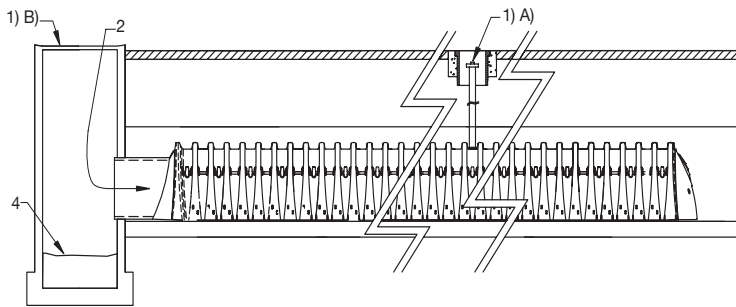

## Sample Maintenance Log

Date	Stadia Rod Readings		Sediment Depth (1)-(2)	Observations/Actions	Inspector
	Fixed point to chamber bottom (1)	Fixed point to top of sediment (2)			
3/15/11	6.3 ft	none		New installation. Fixed point is CI frame at grade	DJM
9/24/11		6.2	0.1 ft	Some grit felt	SM
6/20/13		5.8	0.5 ft	Mucky feel, debris visible in manhole and in Isolator Row Plus, maintenance due	NV
7/7/13	6.3 ft		0	System jetted and vacuumed	DJM

adspipe.com

800-821-6710

# **APPENDIX E**

## **INSPECTION CHECKLISTS**

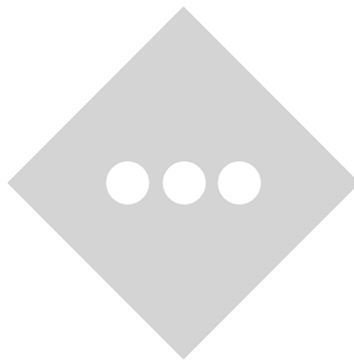

**Primrose Schools Franchising Company**

**885 Main Street, Reading, MA**

Date / Time: \_\_\_\_\_

Days Since Previous Rainfall and Rainfall Amount: \_\_\_\_\_

Inspector: \_\_\_\_\_

**Operation and Maintenance Log**

All oil, sediment and debris to be disposed of in accordance with local, state, and federal guidelines and regulations.

Maintenance Item	Inspection Date	Action Taken	Initials
<b>I. Catch Basins</b> (Inspected four times per year) (Cleaned biannually)			
Inspect & clean existing catch basins to remain prior to construction.			
Oil and sediments to be removed.			
Cleaned biennially or sooner if sediment build up exceeds 6"			
Structural damage or malfunction to be reported to site manager and repaired			
Cleaned immediately after fuel or oil spill.			
During colder periods, the catch basin grates must be kept free of snow and ice.			
During warmer periods, the catch basin grates must be kept free of leaves, litter, sand, and debris.			
Additional inspection, maintenance, and corrective measures taken as needed (please specify):			

Maintenance Item	Inspection Date	Action Taken	Initials
<b>2. Isolator Row Plus - ADS</b> (Inspected four times per year in the first year and twice per year thereafter)			
Clean when sediment reaches 3 inches utilizing the JetVac process outlined in the Isolator Row Plus O&M Manual			
Inspect that system components are in working order and that there are no blockages or obstructions in the inlet or separation screen			
Quantify accumulation of hydrocarbons, trash, and sediment.			
Additional inspection, maintenance, and corrective measures taken as needed (please specify):			
<b>3. Flared End Sections</b> (Inspected as needed)			
Remove & dispose of any trash or debris at outfall			
Remove any obstructions to flow; remove accumulated sediments & debris at outlet and within conduit.			
Additional inspection, maintenance, and corrective measures taken as needed (please specify):			
<b>5. Vegetated Areas</b> (Inspected & maintained annually & as needed)			
Inspect slopes and embankments early in the growing season to identify active or potential erosion problems. Replant bare areas or areas with sparse growth. If erosion is evident, armor the area with an appropriate lining or riprap stone.			
Inspect planted areas on a semi-annual basis and remove any litter.			
Maintain planted areas adjacent to pavement to prevent soil washout. Immediately clean any soil deposited on pavement.			
The grass vegetation should be cut to a height between three and four inches.			

Maintenance Item	Inspection Date	Action Taken	Initials
Pesticide/Herbicide Usage – No pesticides are to be used unless a single spot treatment is required for a specific control application. No pesticides or herbicides are allowed within the 100' adjacent upland resource area or 200' riverfront area without prior approval of the Governing Authority.			
Additional inspection, maintenance, and corrective measures taken as needed (please specify):			

---

**Notes:**

# **APPENDIX F**

## **ANNUAL EVALUATION FORMS**

### **INVENTORY**

**F-1: ANNUAL EVALUATION LOG**

**F-2: AMENDMENT LOG**

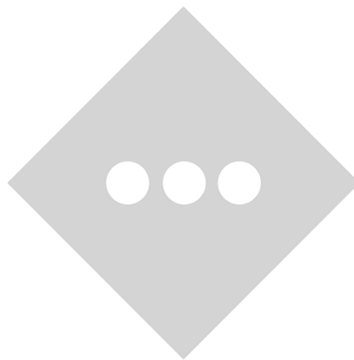

## ANNUAL EVALUATION RECORD

The person responsible for maintenance shall evaluate the effectiveness of the maintenance plan at least once per year and adjust the plan and the deed as needed.

The responsible party should evaluate the effectiveness of the maintenance plan by comparing the maintenance plan with the actual performance of the maintenance. The items to evaluate may include, but not limited to,

- Whether the inspections have been performed as scheduled;
- Whether the preventive maintenance has been performed as scheduled;
- Whether the frequency of preventative maintenance needs to increase or decrease;
- Whether the planned resources were enough to perform the maintenance;
- Whether the repairs were completed on time;
- Whether the actual cost was consistent with the estimated cost;
- Whether the inspection, maintenance, and repair records have been kept.

If actual performance of those items has been deviated from the maintenance plan, the responsible party should find the causes and implement solutions in a revised maintenance plan.

<b>Evaluator(s)</b>	<b>Date of Evaluation</b>	<b>Decision</b>
		<input type="checkbox"/> Maintain current version OR  <input type="checkbox"/> Revise current version Revision date _____ (also update the last revision date on the cover page)  <input type="checkbox"/> Requires a new deed recording (also update the last recording information on the cover page)
		<input type="checkbox"/> Maintain current version OR  <input type="checkbox"/> Revise current version Revision date _____ (also update the last revision date on the cover page)  <input type="checkbox"/> Requires a new deed recording (also update the last recording information on the cover page)
		<input type="checkbox"/> Maintain current version OR  <input type="checkbox"/> Revise current version Revision date _____ (also update the last revision date on the cover page)  <input type="checkbox"/> Requires a new deed recording (also update the last recording information on the cover page)

